

Model VC-8

ADAT/ANALOG Converter

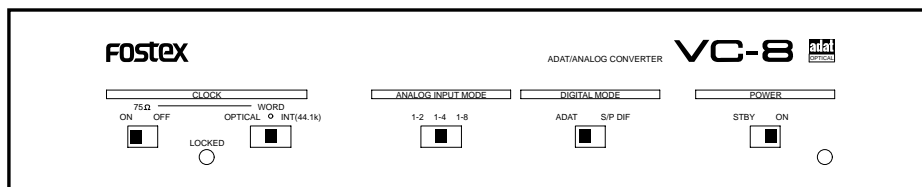



Table of Contents

Safety Instruction.....	2
Introduction.....	3
Precautions.....	3
Outstanding Features.....	3
Names and Functions.....	4
Connecting Examples.....	5
Example at operating it as the ADAT-ANALOG converter.....	5
Example at operating it as the S/P DIF-ANALOG converter.....	8
Specifications.....	9

	CAUTION RISK OF ELECTRIC SHOCK DO NOT OPEN	
<p>CAUTION: TO REDUCE THE RISK OF ELECTRIC SHOCK, DO NOT REMOVE COVER (OR BACK). NO USER - SERVICEABLE PARTS INSIDE. REFER SERVICING TO QUALIFIED SERVICE PERSONNEL.</p>		

CAUTION:
TO PREVENT ELECTRIC SHOCK, MATCH WIDE BLADE OF PLUG TO WIDE SLOT, FULLY INSERT.

ATTENTION:
POUR ÉVITER LES CHOCS ÉLECTRIQUES, INTRODUIRE LA LAME LA PLUS LARGE DE LA FICHE DANS LA BORNE CORRESPONDANTE DE LA PRISE ET POUSSER JUSQU' AU FOND.

"WARNING"

"TO REDUCE THE RISK OF FIRE OR ELECTRIC SHOCK, DO NOT EXPOSE THIS APPLIANCE TO RAIN OR MOISTURE."

SAFETY INSTRUCTIONS

1. Read Instructions - All the safety and operating instructions should be read before the appliance is operated.
2. Retain Instructions - The safety and operating instructions should be retained for future reference.
3. Heed Warnings - All warnings on the appliance and in the operating instructions should be adhered to.
4. Follow Instructions - All operating and use instructions should be followed.
5. Water and Moisture - The appliance should not be used near water - for example, near a bathtub, washbowl, kitchen sink, laundry tub, in a wet basement, or near a swimming pool, and the like.
6. Carts and Stands - The appliance should be used only with a cart or stand that is recommended by the manufacturer.



An appliance and cart combination should be moved with care. Quick stops, excessive force, and uneven surfaces may cause the appliance and cart combination to overturn.

7. Wall or Ceiling Mounting - The appliance should be mounted to a wall or ceiling only as recommended by the manufacturer.
8. Ventilation - The appliance should be situated so that its location or position does not interfere with its proper ventilation. For example, the appliance should not be situated on a bed, sofa, rug, or similar surface that may block the ventilation openings; or, placed in a built-in installation, such as a bookcase or cabinet that may impede the flow of air through the ventilation openings.



The lightning flash with arrowhead symbol, within an equilateral triangle, is intended to alert the user to the presence of uninsulated "dangerous voltage" within the product's enclosure that may be of sufficient magnitude to constitute a risk of electric shock to persons.



The exclamation point within an equilateral triangle is intended to alert the user to the presence of important operating and maintenance (servicing) instructions in the literature accompanying the appliance.

9. Heat - The appliance should be situated away from heat sources such as radiators, heat registers, stoves, or other appliances (including amplifiers) that produce heat.
10. Power Sources - The appliance should be connected to a power supply only of the type described in the operating instructions or as marked on the appliance.
11. Grounding or Polarization - The precautions that should be taken so that the grounding or polarization means of an appliance is not defeated.
12. Power Cord Protection - Power supply cords should be routed so that they are not likely to be walked on or pinched by items placed upon or against them, paying particular attention to cords at plugs, convenience receptacles, and the point where they exit from the appliance.
13. Cleaning - The appliance should be cleaned only as recommended by the manufacturer.
14. Nonuse Periods - The power cord of the appliance should be unplugged from the outlet when left unused for a long period of time.
15. Object and Liquid Entry - Care should be taken so that objects do not fall and liquids are not spilled into the enclosure through openings.
16. Damage Requiring Service - The appliance should be serviced by qualified service personnel when:
 - A. The power supply cord or the plug has been damaged; or
 - B. Objects have fallen, or liquid has been spilled into the appliance; or
 - C. The appliance has been exposed to rain; or
 - D. The appliance does not appear to operate normally or exhibits a marked change in performance; or
 - E. The appliance has been dropped, or the enclosure damaged.
17. Servicing - The user should not attempt to service the appliance beyond that described in the operating instructions. All other servicing should be referred to qualified service personnel.

INTRODUCTION

Thank you very much for having purchased the Fostex Model VC-8.

The VC-8 is an adat/analog converter which allows connections to be made with adat optical exclusive digital multirecorder such as the VR-800 and various analog mixers. In order to accomplish high quality collaboration with analog mixers, the professional 20 bit type are employed for AD/DA.

Also, to build a most effective system matched with the number of analog mixer output BUSes (2 BUS OUT, 4 BUS OUT, 8 BUS OUT) the INPUT MODE switch makes it unnecessary to reconnect the cables at record/playback. Furthermore, the VC-8 can be used as a S/P DIF/analog converter, and by connecting to the sound card contained in various computers with digital input/output, it will give a clean record/playback environment free of internal noise generated in the computer.

Before operating VC-8, it is recommended to thoroughly read this manual to insure long life of this equipment.

Precautions (please read before use)

Power supply

- * When unplugging the AC adaptor from the outlet, be sure to grasp the adaptor. Attempting to unplug it by pulling on the AC cable may damage the wiring.
- * It is dangerous to use any power cable that is cut or frayed. If the power cable is damaged, immediately stop using it, and have it repaired.
- * Do not plug in or unplug the AC adaptor with wet hands. Doing so may result in dangerous electric shock.
- * Do not open the unit or touch any parts inside. Doing so may result in a dangerous electric shock, and could damage the unit.
- * Do not let water or other liquids, flammable materials, or metal objects such as pins get inside the unit. These things may cause electrical shock or short circuit the VC-8, and damage it. If the VC-8 should become wet, unplug the AC adaptor from the AC outlet, and contact your authorized service station.

Location

- * Avoid using the VC-8 in the following locations:
- * Locations of extreme low or high temperatures, or extreme changes in temperature.
- * Locations with excessive moisture or dust.
- * Locations where direct sunlight falls for an extended time, or near a stove or other source of heat.
- * Locations where electrical voltage varies.
- * Unstable locations or where there is heavy vibration.
- * Near strong magnetic fields (on top of a television or speaker).

Outstanding Features

- * A digital multiple system can be setup by using the adat optical and analog in/out converter of the VC-8 together with various analog and digital mixers provided with adat optical such as the VR800.
- * Due to employ of the professional 20 bit AD/DA converter, it is possible in conjunctive operation with the analog mixer without degrading the high quality sound of digital recordings.
- * As the INPUT MODE is switchable, it is possible to construct a system to match the number of BUSes in the analog mixer.
- * Additionally, as S/P DIF can be converted to the analog inputs/outputs and vice versa, it can be connected to the internal sound card of the computer provided with digital inputs/outputs.
- * Either the internal (44.1kHz) or OPTICAL/WORD (Phase adjusting range: 32~48kHz) can be selected and thus it can be widely adapted to digital equipment.

Names and Functions

WORD IN terminal switch
This must be switched ON when the external WORD clock is input.

ANALOG INPUT MODE switch
This switch is used to select the channel to which the ADAT output should be assigned for the signal input to the ANALOG INPUT jack. This switch will be active only when the DIGITAL MODE switch is set to ADAT. Refer to pages 6 and 7 for details.

POWER switch/POWER LED
AC power to the VC-8 is switched ON/OFF (or "standby"). If the VC-8 is not to be used for a long period, the AC adaptor should be unplugged from the wall AC mains.

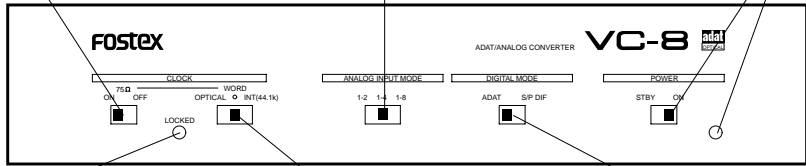

LOCKED LED
This indicates status of the operating clock selected by the CLOCK selector switch. Refer to page 6 for details.

CLOCK selector switch
The VC-8 operating clock (INT, WORD or OPTICAL) is selected by this switch. Refer to page 6 for details.

DIGITAL MODE selector switch
The DIGITAL MODE IN/OUT formats (ADAT or S/P DIF) is selected by this switch. Refer to page 6 for details.

ANALOG INPUT connectors (1-8)
These are connected to BUS OUT (or GROUP OUT) of the analog mixer. Refer to pages 5 and 7 for details.

DIGITAL INPUT/OUTPUT connectors
There are connected to the VR800 digital multitrack recorder or to the DIGITAL IN/OUT connectors of a digital recorder provided only with digital in/out connectors.

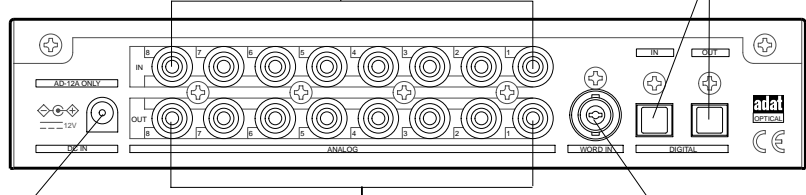

DC IN jack (Center: Plus +)
The AC adaptor (AD-12A) included with the VC-8 is connected here. Do not use an adaptor that is not specified for the VC-8.)

ANALOG OUTPUT connectors (1-8)
These are connected to the TAPE INPUT jacks of the analog mixer. Refer to pages 5 and 7 for details.

WORD IN connector (BNC)
The external WORD clock signal is input here. Refer to page 5 for details.

Connecting Examples

Example at operating it as the ADAT-ANALOG converter

The following connecting schematic is an example of locating the VC-8 between an analog mixer with 8 TAPE IN - 8 BUS OUT (or GROUP OUT) and the VR800 (digital multitrack recorder). In this system, the 8 BUS output from the analog mixer is converted to adat digital signals and the signals of channels 1~8 can be recorded on tracks 1~8 of the VR800.

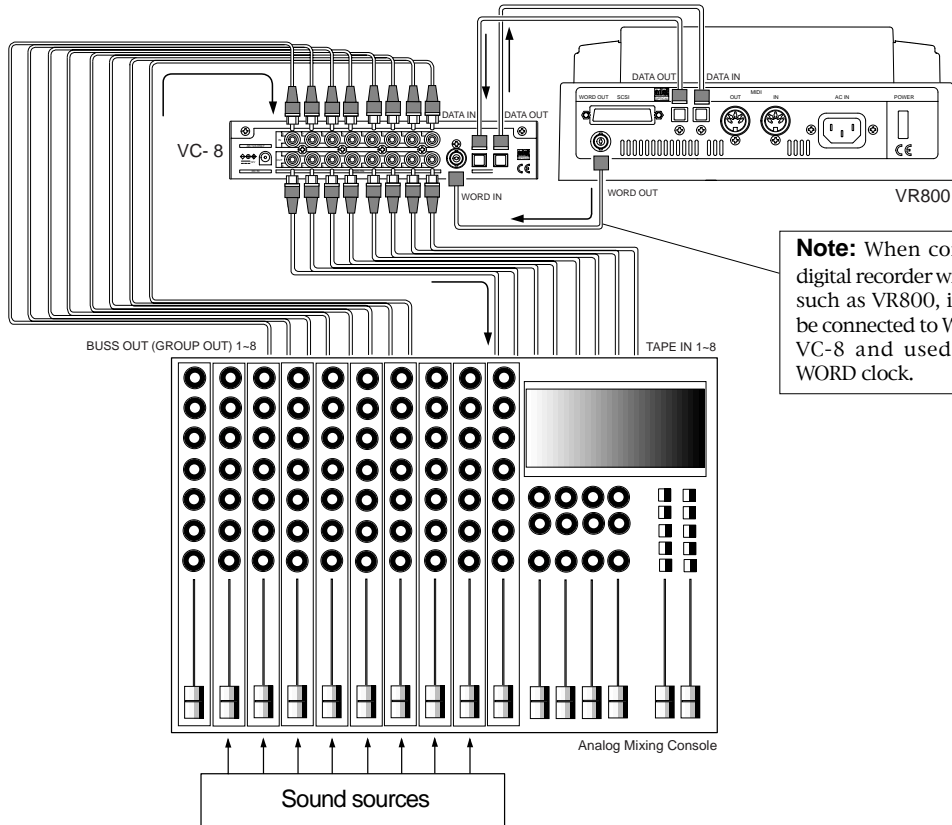

Note: When connecting to a digital recorder with WORD OUT such as VR800, it always must be connected to WORD IN of the VC-8 and used by input of WORD clock.

Note: When the digital inputs and outputs of the VC-8 and VR800 (or another digital recorder) are connected as shown in above connecting schematic, be sure to set one side as the clock master and the other as the clock slave.

In other words, if the VC-8 had been set as the master, then VR800 (or another digital recorder) must be set as the slave, or if in the reverse situation whereas VC-8 had been set as the slave, then VR800 (or another digital recorder) must be set as the master. The most recommended setting at using the VC-8 is to establish the digital recorder as the master and the VC-8 as the slave as shown in table below.

Recorder	VR800: Asynchronous mode Other recorder: Internal mode	VR800: Synchronous mode Other recorder: External mode
VC-8	VR800 (or recorder): Master VC-8: Master	VR800 (or recorder): Slave VC-8: Slave
CLOCK switch ↓ INT (44.1kHz)	△	○
CLOCK switch ↓ WORD or OPTICAL	◎	×

◎	The most recommended setting. Furthermore, if the WORD clock can be input, then WORD must be input.
○	This setting is employed if the recorder (general DAT and MD) has an internal clock and thus cannot accept digital signals.
△	Mutual exchanged of digital signals between the equipment is possible by this setting, but deterioration of sound quality is unavoidable.
×	This setting cannot be used. A digital loop will be created in general type DAT and MD and thus will not operate correctly.

Setup of the VR800

1. Set the VR800 digital input track to [AdAt] and the digital in clock to [ASYnC](Asynchronous mode).
2. Set the VR800 digital output track to [AdAt].

Note: Refer to the VR800 Owner's Manual for setups of the VR800 "Digital input track" and "Digital output track" settings.

Setup of the VC-8

Note: Be sure to switch off power to the VC-8 at setup of the various selector switches. Should the switches be manipulated with power switched on, noise could be created and the VC-8 may not function correctly.

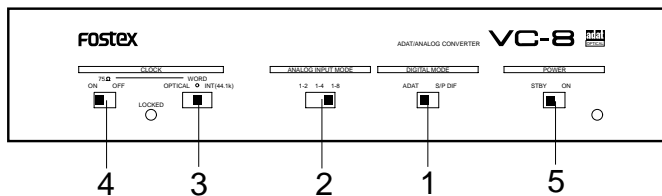

1. Set the DIGITAL MODE switch to [ADAT].

2. Set the ANALOG INPUT switch to [1-8].

If it is to be connected to a 4 BUS or 2 BUS mixer, refer to next page.

3. Set the CLOCK switch to [WORD].

4. Switch ON the terminating switch.

5. Switch on power to the VC-8.

At this stage, as signals are being input to both DATA IN and WORD IN, the LOCKED LED will be lit in orange color.

<The CLOCK switch and LOCKED LED>

The CLOCK switch is for selecting the required clock frequency and is selected in accordance to the application as listed below. Depending on the application, the LOCKED LED indicates the type of digital signal that is input and setting of the CLOCK switch.

CLOCK SW	OPTICAL				WORD				INT (44.1k)			
	WORD IN	OPTICAL IN	LOCKED LED		WORD IN	OPTICAL IN	LOCKED LED		WORD IN	OPTICAL IN	LOCKED LED	
WORD IN	○	—	○	—	○	—	○	—	○	—	○	—
OPTICAL IN	○	○	—	—	○	○	—	—	○	○	—	—
LOCKED LED	Lit in green	Lit in green	Extinguished	Extinguished	Lit in orange	Lit in green	Extinguished	Extinguished	Lit in green	Lit in green	Extinguished	Extinguished
FUNCTIONS	If the LOCKED LED is lit in green, the VC-8 will operate in sync with the digital signal input to the VC-8 DATA IN connector. If the LOCKED LED is extinguished, it indicates that no digital signal is being input and it will not operate correctly even though switched to OPTICAL. In such case, set the CLOCK switch to INT.				If the LOCKED LED is lit in red or orange, the VC-8 will operate in sync with the word clock that is input to the VC-8 WORD IN connector. If the LOCKED LED is lit in green or is extinguished, it is an indication that word clock is not being input and thus will not operate correctly even though the CLOCK switch is set to WORD. In such case, set the CLOCK switch to OPTICAL or INT.				Regardless to the LOCKED LED indication, the VC-8 will operate by its internal 44.1 kHz crystal.			

When connecting a 4 BUS OUT mixer

Connect the mixer BUS OUT to INPUT 1~4 of the VC-8 and select [1-4] of the VC-8 ANALOG INPUT MODE switch. Signals input to ANALOG IN 1~4 will be assigned, respectively, to ADAT outputs 1~4 and 5~8. In other words, the ANALOG IN 1~4 signals will be simultaneously sent to tracks 1~4 and 5~8, thus 4 tracks each can be recorded without re-connecting the cables.

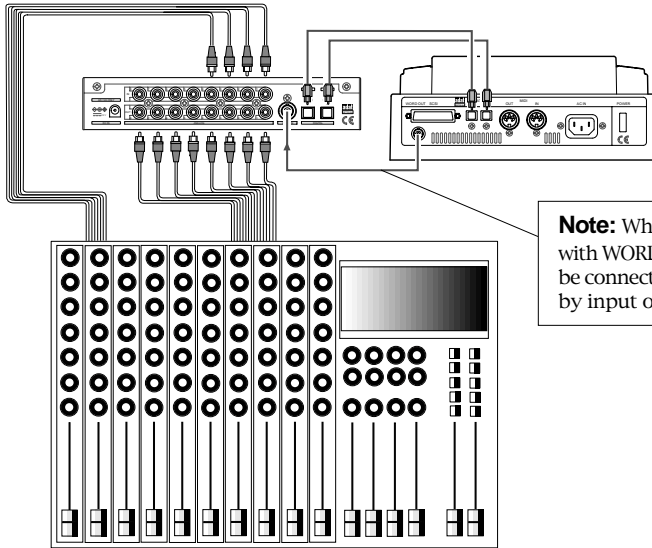

Note: When connecting to a digital recorder with WORD OUT such as VR800, it always must be connected to WORD IN of the VC-8 and used by input of WORD clock.

When connecting a 2 BUS OUT mixer

Connect the mixer BUS OUT to INPUT 1~2 of the VC-8 and select [1-2] of the VC-8 ANALOG INPUT MODE switch. Signals input to ANALOG IN 1~2 will be assigned, respectively, to ADAT outputs 1~2, 3~4, 5-6 and 7-8. In other words, the ANALOG IN 1~2 signals, in the above combinations, will be simultaneously sent to each 2 tracks for recording without re-connecting the cable.

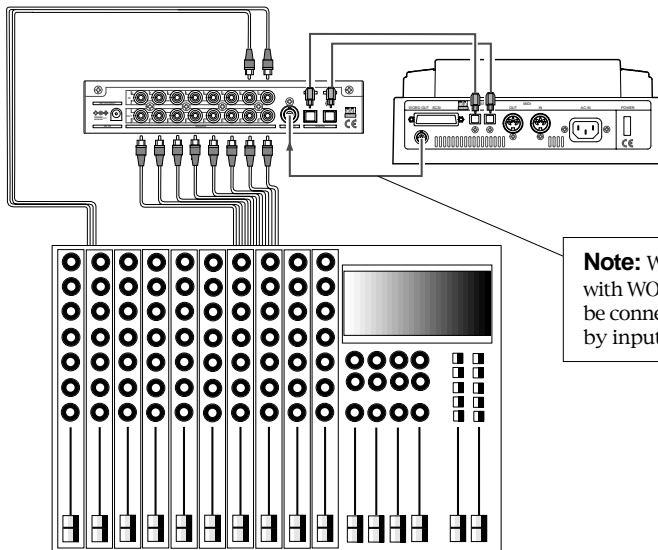

Note: When connecting to a digital recorder with WORD OUT such as VR800, it always must be connected to WORD IN of the VC-8 and used by input of WORD clock.

Example at operating it as the S/P DIF-ANALOG converter

The following is a connecting example of using the VC-8 as a S/P DIF-ANALOG converter which makes it possible to extract sound from CD and DVD with the sound card contained in the computer with S/P DIF digital output. By separating the analog circuit from the computer, this system can playback (or record) a clear sound free of noise created in the computer.

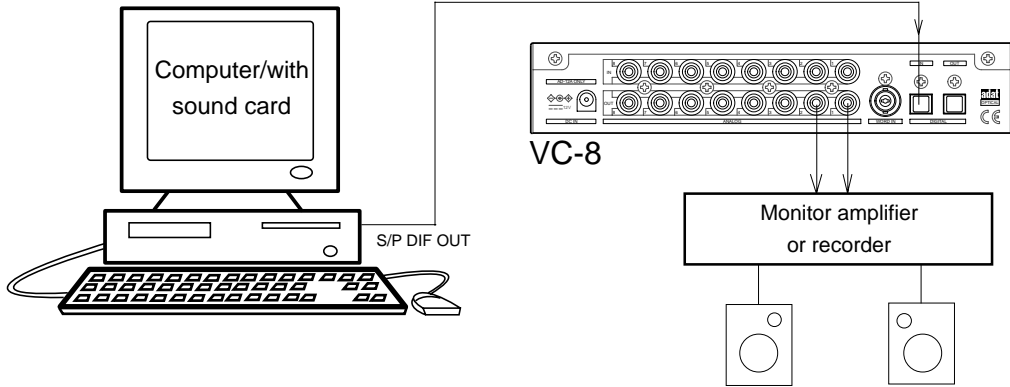

Setup of the VC-8

Note: Be sure to switch off power to the VC-8 at setup of the various selector switches. Should the switches be manipulated with power switched on, noise could be created and the VC-8 may not function correctly.

Note: The ANALOG INPUT MODE switch will not function when the DIGITAL MODE switch is used for [S/P DIF].

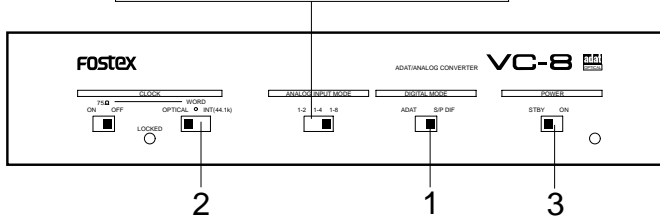

1. Set the DIGITAL MODE switch to [S/P DIF].
2. Set the CLOCK switch to [OPTICAL].
3. Switch on power to the VC-8.

<Other application examples>

When using the Fostex Mode D-160 16 track digital recorder, it can simultaneously record 16 tracks of analog signals by connecting the VC-8 as shown below.

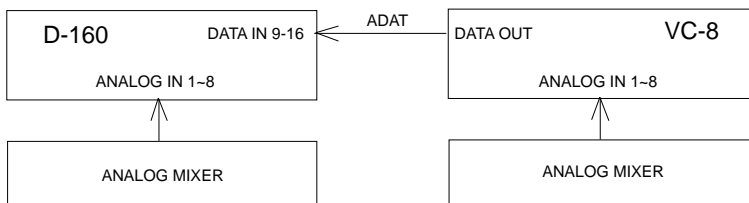

Specifications

< INPUT x 8 >

- Connector : RCA pin jack (x 8)
- Input Impedance : 20k or more
- Input Level : -10dBV

< OUTPUT x 8 >

- Connector : RCA pin jack (x 8)
- Load Impedance : 10k or more
- Output Level : -10dBV

< DATA IN/OUT >

- Connector : OPTICAL (x 2)
- Format : 1. IEC60958 (S/P DIF)
2. Alesis Proprietary Multi Channel Optical Interface (Switched to 1 or 2.)

< WORD IN >

- Connector : BNC type (x 1)
- Input Level : TTL Level
- Input Impedance : 75 (terminator switched On/OFF)

< OTHERS >

- AD : 20 bit 64 times over sampling modulation
- DA : 20 bit 128times over sampling modulation
- Sampling Frequency : INT mode : 44.1kHz
: OPTICAL/WORD mode : 32 ~ 48kHz
- Total Harmonic distortion : 0.008%(@ 1kHz, TYPICAL)
- Dynamic Range : 96dB (TYPICAL)

< GENERAL >

- Dimensions : 220 (W) x 43 (H) x 180 (D) mm
- Weight : 1.0kg (Excluding accessories)
- Power Supply : DC12V, 600mA, Exclusive AC Adaptor (AD-12A)

* Specifications and appearance are subjects to change without notice for product improvement.

* Adat and the  marks are trademarks of Alesis Corporation.

Declaration of EC Directive

This equipment is compatible with the EMC Directive (89/336/EEC) - Directive on approximation of member nation's ordinance concerning the electromagnetic compatibility and with the Low Voltage Directive (73/23/EEC) - Directive on approximation of member nation's ordinance concerning electric equipment designed to be used within the specified voltage range.

The Affect of Immunity on This Equipment

The affect of the European specification EN50082-1 (coexistence of electromagnetic waves - common immunity specification) on this equipment are as shown below.

* In the electrical fast transient / burst requirements, radiated electromagnetic field requirements and static electricity discharging environment, this could be affected by generation of noise in some cases.

FOSTEX DISTRIBUTORS LIST IN EUROPE

* Including non - EU countries. * underlined: contracted distributors (as of November, 1997)

<AUSTRIA>

NAME: ATEC Audio-u. Videogeraete VertriebsgesmbH.
ADD: Im Winkel 5, A-2325 Velm, Austria
TEL: (+43) 2234-74004, FAX: (+43) 2234-74074

<BELGIUM>

NAME: EML N. V.
ADD: Bijvenestraat 1A, B3500 Hasselt, Belgium
TEL: (+32) 11-232355, FAX: (+32) 11-232172

<DENMARK>

NAME: SC Sound ApS
ADD: Malervej 2, DK-2630 Taastrup, Denmark
TEL: (+45) 4399-8877, FAX: (+45) 4399-8077

<FINLAND>

NAME: Norettron Audio
ADD: Tonttumuorinkuja 4, FIN-02200 Espoo, Finland
TEL: (+358) 0-5259330, FAX: (+358) 0-52593352

<FRANCE>

NAME: Musikengro
ADD: ZAC de Folliouses, B. P. 609, 01706 Les Echets, France
TEL: (+33) 72 26 27 00, FAX: (+33) 72 26 27 01

<GERMANY>

NAME: Studiosound & Music GmbH
ADD: Scheppe Gewissegasse 8, D-35039 Marburg, Germany
TEL: (+49) 6421-12071, FAX: (+49) 6421-15522

<GREECE>

NAME: Bon Studio S. A.
ADD: 6 Zaimi Street, Exarchia, 106.83 Athens, Greece
TEL: (+30) 1-3809605-8, 3302059, FAX: (+30) 1-3845755

<ICELAND>

NAME: I. D. elrf. electronic Ltd.
ADD: Armula 38 108 Reykjavik, Iceland
TEL: (+354) 588 5010, FAX: (+354) 588 5011

<ITALY>

NAME: Recoton Italia Srl.
ADD: V. 1 Maggio, N 18, 40050 Quarto Inferiore, (BO) Italy
TEL: (+39) 51-768576, FAX: (+39) 51-768336

<THE NETHERLANDS>

NAME: IEMKE ROOS AUDIO B. V.
ADD: Kuiperbergweg 20, 1101 AG Amsterdam, The Netherlands
TEL: (+31) 20-697-2121, FAX: (+31) 20-697-4201

<NORWAY>

NAME: Siv. Ing. Benum A/S
ADD: P. O. Box 145 Vinderen, 0319 Oslo 3, Norway
TEL: (+47) 22-139900, FAX: (+47) 22-148259

<PORTUGAL>

NAME: Caius - Tecnologias Audio e Musica, Lda.
ADD: Rua de Santa Catarina, 131 4000 Porto, Portugal
TEL: (+351) 2-2084456/325400, FAX: (+351) 2-314760

<SPAIN>

NAME: Multitracker. S. A.
ADD: C/Garcilaso No. 9, Madrid 28010, Spain
TEL: (+34) 1-4470700, 1-4470898, FAX: (+34) 1-5930716

<SWEDEN>

NAME: TTS Tal & Ton Studioteknik AB
ADD: Gelbgjutarevagen 4, S-171 48 Solna, Sweden
TEL: (+46) 8-7340750, FAX: (+46) 8-824476

<SWITZERLAND>

NAME: Audio Bauer Pro AG
ADD: Bernerstrasse-Nord 182, CH-8064 Zurich, Switzerland
TEL: (+41) 1-4323230, FAX: (+41) 1-4326558

<UK>

NAME: SCV London
ADD: 3A 6-24 Southgate Road, London N1 3JJ, England, UK
TEL: (+44) 171-923-1892, FAX: (+44) 171-241-3644