

Reference Manual

8 Track Digital Recorder

Model **D824**

16 Track Digital Recorder

Model **D1624**

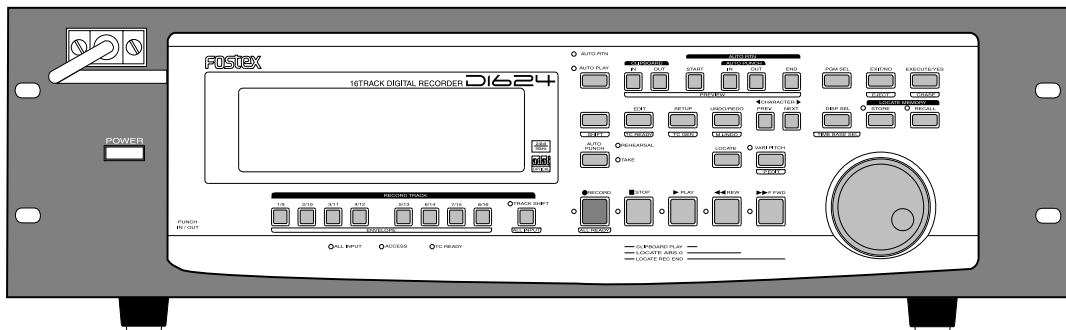

<About this manual>

This manual is the Reference Manual for the Model D824/D1624.

Because all keys and buttons on the Model D824 and D1624 are identical, most descriptions are done based on the Model D1624.

Please note any differences between the Model D824 and D1624, the explanation or note for each model will be described.

Fostex[®]

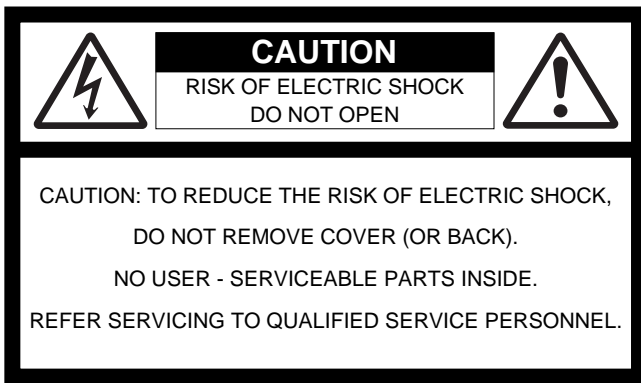

"WARNING"

"TO REDUCE THE RISK OF FIRE OR ELECTRIC SHOCK, DO NOT EXPOSE THIS APPLIANCE TO RAIN OR MOISTURE."

SAFETY INSTRUCTIONS

1. Read Instructions - All the safety and operating instructions should be read before the appliance is operated.
2. Retain Instructions - The safety and operating instructions should be retained for future reference.
3. Heed Warnings - All warnings on the appliance and in the operating instructions should be adhered to.
4. Follow Instructions - All operating and use instructions should be followed.
5. Water and Moisture - The appliance should not be used near water - for example, near a bathtub, washbowl, kitchen sink, laundry tub, in a wet basement, or near a swimming pool, and the like.
6. Carts and Stands - The appliance should be used only with a cart or stand that is recommended by the manufacturer.



An appliance and cart combination should be moved with care. Quick stops, excessive force, and uneven surfaces may cause the appliance and cart combination to overturn.

7. Wall or Ceiling Mounting - The appliance should be mounted to a wall or ceiling only as recommended by the manufacturer.
8. Ventilation - The appliance should be situated so that its location or position does not interfere with its proper ventilation. For example, the appliance should not be situated on a bed, sofa, rug, or similar surface that may block the ventilation openings; or, placed in a built-in installation, such as a bookcase or cabinet that may impede the flow of air through the ventilation openings.

CAUTION:

TO PREVENT ELECTRIC SHOCK, MATCH WIDE BLADE OF PLUG TO WIDE SLOT, FULLY INSERT.

ATTENTION:

POUR ÉVITER LES CHOCS ÉLECTRIQUES, INTRODUIRE LA LAME LA PLUS LARGE DE LA FICHE DANS LA BORNE CORRESPONDANTE DE LA PRISE ET POUSSER JUSQU' AU FOND.



The lightning flash with arrowhead symbol, within an equilateral triangle, is intended to alert the user to the presence of uninsulated "dangerous voltage" within the product's enclosure that may be of sufficient magnitude to constitute a risk of electric shock to persons.



The exclamation point within an equilateral triangle is intended to alert the user to the presence of important operating and maintenance (servicing) instructions in the literature accompanying the appliance.

9. Heat - The appliance should be situated away from heat sources such as radiators, heat registers, stoves, or other appliances (including amplifiers) that produce heat.
10. Power Sources - The appliance should be connected to a power supply only of the type described in the operating instructions or as marked on the appliance.
11. Grounding or Polarization - The precautions that should be taken so that the grounding or polarization means of an appliance is not defeated.
12. Power Cord Protection - Power supply cords should be routed so that they are not likely to be walked on or pinched by items placed upon or against them, paying particular attention to cords at plugs, convenience receptacles, and the point where they exit from the appliance.
13. Cleaning - The appliance should be cleaned only as recommended by the manufacturer.
14. Nonuse Periods - The power cord of the appliance should be unplugged from the outlet when left unused for a long period of time.
15. Object and Liquid Entry - Care should be taken so that objects do not fall and liquids are not spilled into the enclosure through openings.
16. Damage Requiring Service - The appliance should be serviced by qualified service personnel when:
 - A. The power supply cord or the plug has been damaged; or
 - B. Objects have fallen, or liquid has been spilled into the appliance; or
 - C. The appliance has been exposed to rain; or
 - D. The appliance does not appear to operate normally or exhibits a marked change in performance; or
 - E. The appliance has been dropped, or the enclosure damaged.
17. Servicing - The user should not attempt to service the appliance beyond that described in the operating instructions. All other servicing should be referred to qualified service personnel.

Contents

Introduction	6
Main Features	6
Precautions	7

Names and Functions

Front panel section	9
Detachable controller section	10
Rear panel section	17
Display section	19
Display shown when the power is turned on.....	19
Preset display.....	19
Switching the display using the DISP SEL key.....	20
Switching the time base display using the SHIFT key and DISP SEL key.....	20
Changing programs using the PGM key.....	21
Warning display.....	21

Before Starting

Time Base	23
Recording method and REMAIN indicator	24
Managing songs by program change function	25
Real tracks and Additional tracks	26
Input monitoring and playback monitoring	27
Audio file and event	28

Formatting and Optimizing disks

Formatting a current drive disk	30
Formatting a brand new hard disk.....	31
Reformatting an E-IDE hard disk.....	32
Formatting a backup disk (SCSI disk)	32
Optimizing the disk	33

Handling Programs

Creating a new program	34
Duplicating a program	35
Using a program change function	36
Deleting a program	36
Editing a program title	37

Punch In/Out

When is Punch In/Out recording	39
Auto Punch In/Out	39
Preparation.....	39
Rehearsing Auto Punch In/Out.....	41
Auto Punch In/Out Take.....	42
Single undo/redo auto punch in/out.....	42
Manual Punch In/Out	43
Preparation.....	43
Rehearsing Manual Punch In/Out.....	43
Manual Punch In/Out Take.....	44
Single undo/redo manual punch in/out.....	45

Recording Digital data

Digital recording from an external digital device	46
Digital recording to an external digital device	48
Connecting a Digital Mixer	50

Recording to a Metronome Sound

Executing of record	52
----------------------------------	-----------

Storing a Locate Point	
Storing and editing the locate points to the memory keys.....	54
Storing in real-time.....	54
Editing and stored data.....	54
Storing and editing LOCATE key.....	53
Storing in real-time.....	53
Edit and re-store data that is already stored.....	56
Locate Function	
Direct Locate.....	57
Auto Play function.....	58
Auto Return function.....	58
Auto Repeat function.....	59
Cue & Review Function	
Cue & Review function using the REWIND and F FWD buttons.....	60
Cue & Review function using the SHUTTLE dial.....	60
Digital scrubbing using the envelope function.....	60
Preview Function	
Executing the preview function.....	63
Trimming the sound while previewing.....	63
Multiple Undo Function	
Using the Multiple Undo function.....	64
Editing Tracks	
Copy & Paste and Move & Paste.....	66
Storing the edit point.....	67
Checking and adjusting the edit points.....	67
Executing Copy (or Move).....	67
Checking the clipboard data.....	67
Executing Paste.....	68
Single undo/redo Paste.....	68
Copy & Paste between programs.....	69
Checking the clipboard data.....	69
Erase.....	70
Storing the edit points.....	70
Checking and adjusting the edit points.....	71
Executing Erase.....	71
Single undo/redo Erase.....	71
Track Exchange.....	72
Executing track exchange.....	73
MIDI Sync Function	
MIDI clock sync system.....	74
Connecting external equipment.....	74
Setup of the recorder.....	75
Confirming the MIDI clock sync.....	75
Executing of recording.....	76
MTC sync/MIDI machine control system.....	76
Setup to external equipment.....	77
Setup of external equipment.....	77
Setup of the recorder.....	77
Confirming MTC sync/MMC.....	78
Executing of recording.....	78
Multitrack system by the slave mode.....	79
Equipment interconnections.....	79
Setup of the recorder (#1): <Master>.....	79
Setup of the recorder (#2) and (#3): <Slave>.....	80
Check chase lock.....	81
Selecting a record track.....	81
Executing of recording.....	81

External MIDI equipment sync system by the slave mode.....	82
Connection to external equipment.....	82
Setup of external equipment.....	82
Setup of the recorder.....	82
Confirming chase lock.....	83
Executing of recording.....	83

Saving and Loading Song Data

About saved and loaded data.....	84
Saving the data using DIGITAL/DATA OUT.....	86
Connecting an external device.....	86
Setting up an external device.....	86
Executing the save operation.....	86
Loading the data using DIGITAL/DATA IN.....	88
Connecting the external device.....	88
Setting up an external device.....	88
Executing the load operation.....	88
Saving the data using SCSI.....	90
Connecting a SCSI device.....	90
Formatting a SCSI disk.....	91
Saving data of an individual program.....	92
Loading the data using SCSI.....	94
Load the data saved on one removable disk.....	94
Load the data saved on several removable disks.....	95
Save/Load by "WAV" file.....	96
Saving of "WAV" files.....	96
Loading "WAV" files.....	99

Changing the Initial Setting (SETUP mode)

Selecting SETUP menu.....	102
Time Signature Setting.....	103
Setting a Tempo.....	105
Setting the Metronome function.....	107
Setting a Preroll Value.....	108
Setting MIDI Sync Output Signal.....	109
Setting an MTC Frame Rate.....	109
Setting an MTC Offset Value.....	110
Setting Offset Mode.....	111
Setting the Slave Type.....	112
Setting the Record Protect function.....	112
Setting Digital Input.....	113
Setting Digital Output.....	114
Setting BAR/BEAT Resolution Mode.....	115
Setting the MIDI Device Number.....	116
Setting the Operating Clock.....	117
Checking the Number of Track Events.....	118
The Drive Format Information.....	119
Drive Setting.....	121
MIDI Implementation Chart.....	122
MMC Command List.....	123
Inquiry Message List.....	123
Fostex MIDI System Exclusive Message.....	124
Status Request.....	125
Data Type.....	127
Explanation on the Command/Mode set.....	129
The Status Request/Command.....	131
Explanation on the Status Reply.....	132
Maintenance.....	134
Specifications.....	135

APPENDIX (Operational manual for the recorder with the Model 8345 TC/SYNC card installed)

Introduction

This is a digital recorder installed with a 3.5 inch E-IDE hard disk recording media for recording, playback and editing real tracks (D824=8 tracks, D1624=16 tracks) with an additional track.

Together with non-compression recording by quantized 16bit/44.1kHz or 48kHz, 24bit/44.1kHz or 48kHz, or 24bit/96kHz (8 track), it also contains about input/output (By switch to S/P DIF). In addition to analog simultaneous record and playback, digital recording (S/P DIF or adat) by using the DIGITAL/DATA input/output, it also complies to simultaneous recording of analog input+digital inputs (S/P DIF or adat).

Therefore, a 100% digital recording System can be built by combining various digital mixers.

In regards to backup of song data, in addition to conventional DAT, the original adat backup function is supported making possible high speed backup using the standard installed SCSI connector.

By installing the optional Model 8345 TC/SYNC card, in addition to phasing against the standard WORD clock, it will also comply to slave operation by external LTC and phasing against the VIDEO reference signal. Moreover, by installing the optional Model 5042 balancing 8-8 I/O card (Exclusive for D824; sold separately) or the Model 5043 balancing 8-16 I/O card (Exclusive for D1624; sold separately), +4dBu analog balanced input/output can be added.

Main features

The unit's recorder section uses a recording format called FDMS-3 Ver 2.0 (Fostex Disk Management System-3). It uses an E-IDE hard disk as the recording media.

- A removable cartridge for easy installation and replacement of the hard disk at the front panel is employed.
- The recorder features non-destructive audio editing (a great advantage of digital recording) such as Copy & Paste, Move & Paste, Erase, etc. You can choose Time Base (ABS or MTC) or MIDI bar/beat/clock as the recorder.
- It contains the "Track exchange function" to allow exchanges between real tracks or between real track and the additional track.
- A "Preview function" allows for an intuitive fine-adjustment of an editing point (locate point).
- "Single undo/redo" for reprocessing record/edit mistakes and "Multiple undo" by time jump is possible (On/off can be set when formatting).
- A "Vari Pitch function" allows you to fine-tune the pitch.
- A digital input setup function is provided making it possible to make a stereo digital recording by assigning to tracks 1 and 2 the S/P DIF digital signals from CDs or MDs, or a digital recording on all 8 tracks an adat digital signal.
- A digital output setup function is provided to digitally output, by selecting from the real track, any 2 output sources (S/P DIF) or 8 output sources (adat).
- You can also use the DIGITAL/DATA INPUT and OUTPUT jacks to an external DAT or adat, and to save and load song data (audio data and SETUP mode settings) to and from the DAT or adat.
- High-speed SCSI Save/Load is also an option by connecting a non-DAT or adat SCSI backup drive. WAV file Save/Load is possible by using a DOS formatted SCSI type disk.
- In addition to cueing by JOG/SHUTTLE, digital scrubbing using the envelope function is also possible.
- MIDI clock and Song Position Pointer can be transmitted according to the internal programmable Tempo Map. You can set up a synchronization system with a sequencer or a rhythm machine without wasting a track.
- You can use the recorder as a sync slave machine by sending MTC from a connected device.
- The recorder supports MTC, MMC, and Fostex System Exclusive Message, which allows for advanced control and high-precision synchronization from external sequencing software. You can set the device number and MTC frame rate for MMC and Fostex System Exclusive Message. Also, "MTC Offset function" and "Offset Mode function" are useful for setting up a sync environment using an external sequencing software.
- Auto Punch In/Out and Manual Punch In/Out functions offer two modes: "Take" for a real recording, and "Rehearsal" for monitoring the part between the in and out points.
- The "Program Select function" enables you to select a song from up to 99 songs and name the songs.
- A "Bar/Beat Resolution function" is used to edit audio at the beginning of the beat (round up or round off to a beat).
- The "Metronome function" can be used as a rhythm guide for recording.
- Various edit functions using an edit point (locate point), such as Copy & Paste, Move & Paste, Erase, Auto Punch In/Out, Auto Locate, are available. You can also locate ABS 0 or REC END regardless of the edit point (locate point).
- A maximum of 99 Locate Pointers can be programmed for a LOCATE only feature. Simply select the LOCATE number desired for swift location.
- You can set a preroll time of 0 to 10 seconds.
- A "Disk Remain Display function" offers a clear indication of available recording time and disk space (in mono track recording). You can choose the Time Base from ABS, MTC, and BAR/BEAT/CLK.

Precautions

- Be sure to connect the recorder to the power supply specified in the Specifications section of this Reference Manual. Do not use an AC outlet of any other voltage.
- Do not connect the recorder to the same AC outlet to which devices that could generate noise (such as a large motor or dimmer), or the devices that consume a large amount of power (such as an air conditioning system or large electric heater) are connected.
- If you use the recorder in an area with a different power voltage, first consult your dealer or the nearest FOSTEX service station. You can use the recorder with a power frequency of 50Hz or 60Hz.
- It is very dangerous to use a power cord that is frayed or damaged. In such a case, stop using the recorder immediately and ask your dealer to repair the cord.
- To avoid possible electric shock and damage to the recorder, avoid contact with water or other liquids, or do not handle the power plug while your hands are wet.
- To prevent possible electric shock and damage to the recorder, do not remove the main unit cover or reach the inside the unit.
- Do not let water or other liquid, or metal objects such as pins, accidentally enter the inside of the recorder because this may lead to electric shock or damage. Should water enter the inside of the recorder, remove the power plug from the AC outlet, and consult your dealer or the nearest FOSTEX service station.
- To prevent damage to the recorder, be sure to power on the connected devices first, then turn on the power to the recorder.
- Before turning the power off to the recorder, first quit SETUP mode and make sure that the recorder section is stopped.
Especially, never attempt to turn off the power to the recorder while the hard disk is accessing data (the HD ACCESS LED is lit or flashing). Otherwise, not only will you lose recorded data, but you may damage to the recorder.
FOSTEX is not responsible for the data lost during operation of the recorder.
- Before you change the location of the recorder, pack the recorder in the shipping carton or an impact-resistant case. Make sure that the recorder is kept free from external vibration or impact since the recorder is very sensitive to vibration.
- Do not install the recorder in locations subject to the following:
 - * Extremely high or low temperature, or significant changes in temperature.
 - * Excessive humidity or dust.
 - * Excessive changes in power supply voltage.
 - * Unstable or significantly vibrating or shaking surfaces.
 - * Near a strong magnetic field (such as a TV or speaker).
- If you move the recorder from a place with an excessively low temperature to a warm place, or if you use the recorder in a room in which the temperature varies significantly during winter, condensation may occur on the hard disk or other parts. In such cases, leave the recorder for about an hour in the new location before you turn on the power.

Note on repair

- This recorder does not use any parts that users can repair easily. Contact your dealer or the nearest FOSTEX service station to ask about repairs.
- Use the packing carton designed for the recorder when you transport the recorder to the dealer for repair or return.
If you have discarded the packing box, try to pack the recorder completely using shock absorbing materials. Fostex is not responsible for malfunction or damage due to incomplete packaging or caused during transport.

About copyrights

- It is prohibited by law to use any part of a CD recording or video images or audio data for which copyright is possessed by a third party for commercial purposes such as contents, broadcasts, sales, or distribution- any purpose other than for your personal pleasure.

About damage

- FOSTEX is not responsible for any “direct damage” or “indirect damage” caused by using the recorder.

D824 front panel

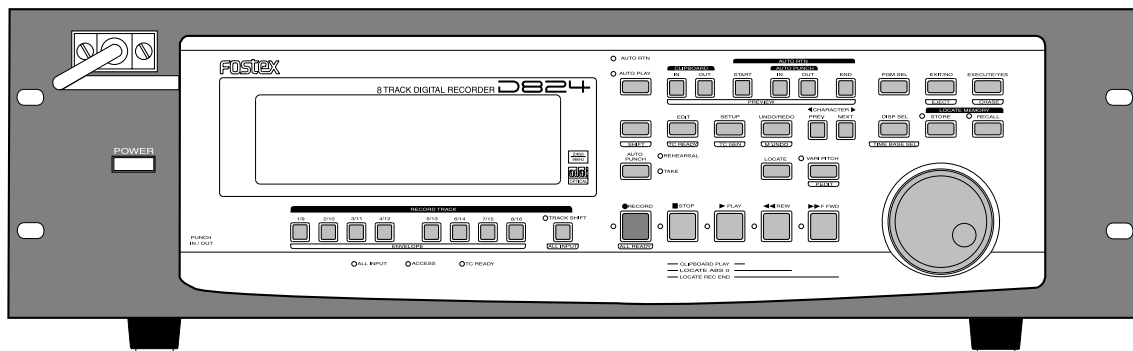

D824 rear panel

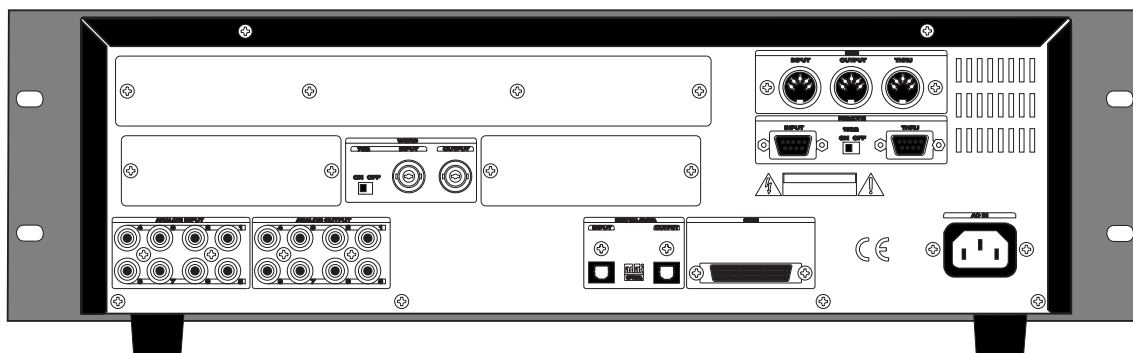

D1624 front panel

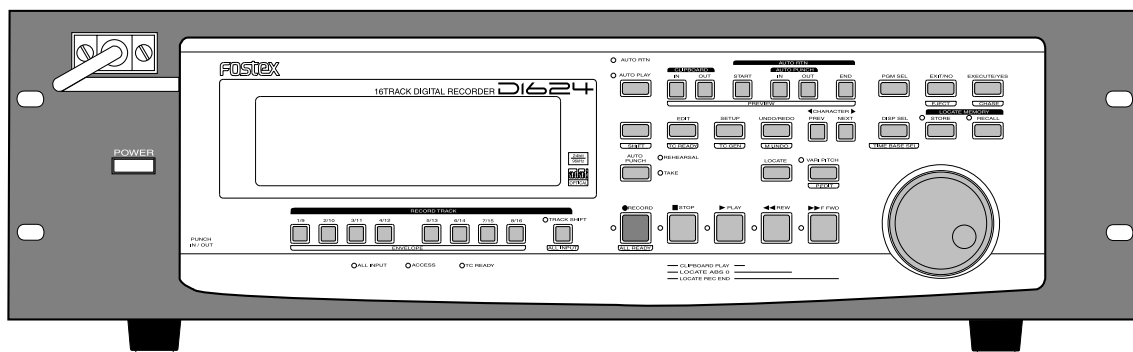

D1624 rear panel

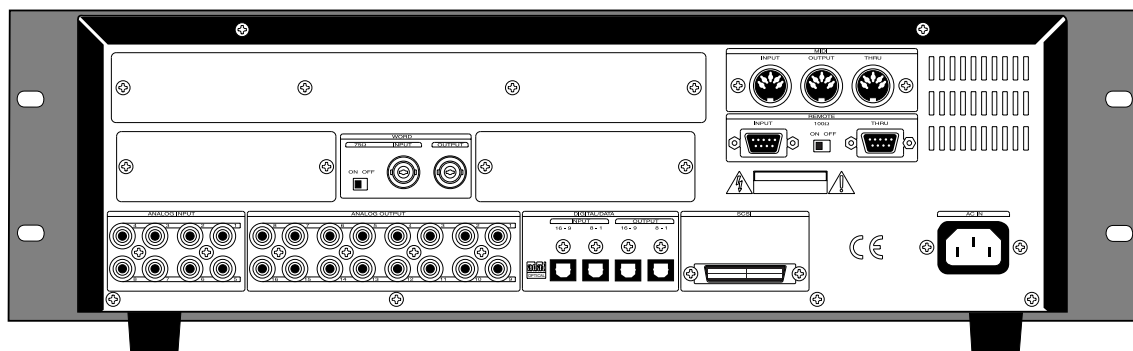

Names and Functions

Front Panel section

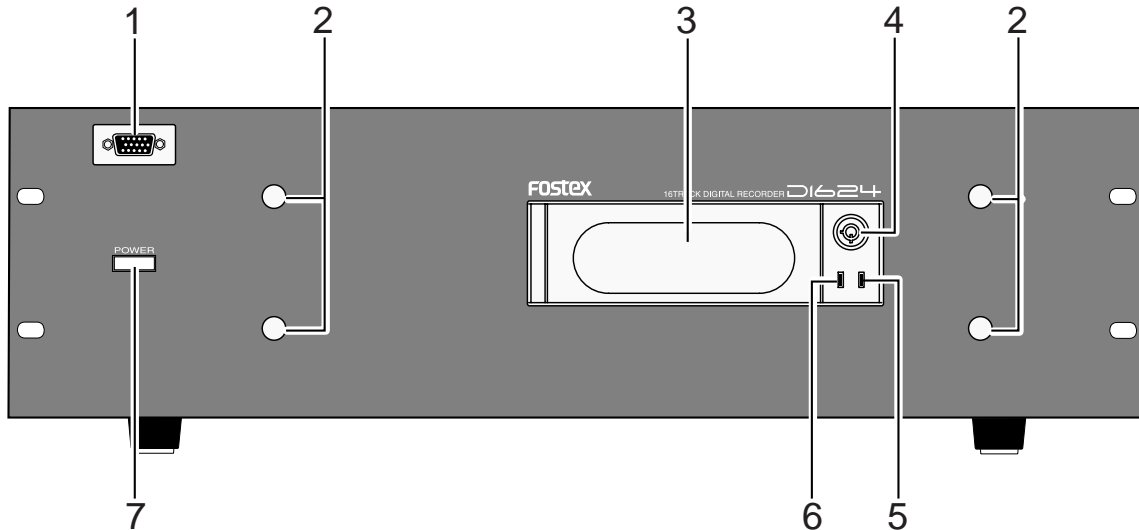

1. Detachable remote controller connector

The detachable remote controller is connected here. You can remove the controller. Connect the optional extension cable (Model 8551) to extend the distance.

2. Controller mount

The detachable remote controller is mounted on the front panel.

3. Removable hard disk cartridge slot

This slot is used to insert a removable hard disk cartridge. This system allows you to replace the hard disk easily.

* Refer to "Quick operation Guide" for more information on how to replace the removable hard disk cartridge.

<Note>

* This slot is covered by a dust-proof panel when the recorder is shipped from the factory. Remove this panel in order to insert a cartridge.

* The recorder package contains a removable case (without a hard disk). Install your hard disk in this removable case.

4. Lock/Unlock key

When you remove or install the hard disk cartridge, you need to lock/unlock here using the included key.

5. Hard disk power LED (Green)

This LED lights up if the hard disk operates correctly when you turn the power on to the recorder. If the Lock key is unlocked, the power to the hard disk will not be turned on, and the LED will not light up.

6. Hard disk access LED (Red)

This LED lights up or blinks when the hard disk is writing or reading data. (Same as the ACCESS LED on the detachable remote controller.)

7. Power switch

This switch turns the main power to the recorder on/off.

<WARNING !>

Before turning the power off to the recorder, first quit the SETUP mode and make sure that the recorder section is stopped.

Especially, never attempt to turn off the power to the recorder while the hard disk is accessing data (the ACCESS LED is lit or flashing). Otherwise, not only will you lose recorded data, you may damage to the unit.

<Note>

Should this power switch be switched On/Off in quick succession, in some cases it will fail to switch On at all. This is due to functioning of the internal protection circuit and is not a breakdown. Consequently, should such a symptom appear, switch Off power for a moment, then switch On again after waiting 1 or 2 minutes.

Detachable Controller section

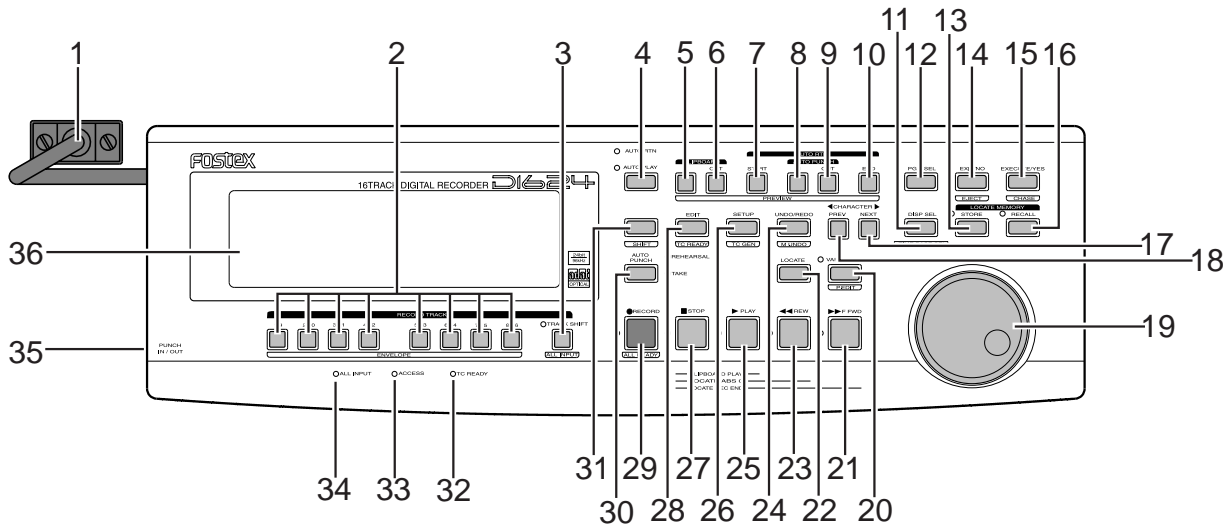

1. Controller Connection Cable

Connect this cable to the recorder controller connection jack.

2. Record Track Select key [RECORD TRACK]

Select "SAFE-READY" of the track to record. Pressing the key once will cause the corresponding track to enter the READY mode, and the track displayed (□) will flash. Pressing the key again will cause the corresponding track to enter the SAFE mode, and the track display to turn OFF. When you only press the RECORD button in the READY mode, the track that is READY will enter the input monitor state, and the recording level can be adjusted. Pressing the RECORD button again will put the system back in the REPRODUCTION MONITOR state. You can also use this key to select tracks to copy & paste, move & paste, erase and other editing features, as well as to execute the envelope feature.

<Note>
 The keys for tracks 1-8 will function on the D824 and, for tracks 1-16 on the D1624. However, if the D1624 is formatted in 96kHz/24bit, tracks 1-8 will function the same as the D824.

* Refer to page "27" for details about the reproduction monitor and the input monitor.

3. Track shift key [TRACK SHIFT]

<Function only for D1624>

When the TRACK SHIFT LED is lit by pressing this key, SAFE-READY can be executed for record tracks 9-16 (Except when formatted in 96kHz/24bit). This does not function on the D824.

<Common function for D824/D1624>

The input monitor for all tracks can be switched ON/OFF with each press of this key while pressing on the SHIFT key. When all tracks are set to input monitor, ALL INPUT LED will light.

* Refer to page "27" for details about the reproduction monitor and the input monitor.

4. Auto Play/Auto Return key [AUTO RTN/PLAY]

Pressing this key repeatedly will change Auto Play mode, Auto Return mode, and Repeat mode On/Off as follows: (○ : LED off, ● : LED light up)

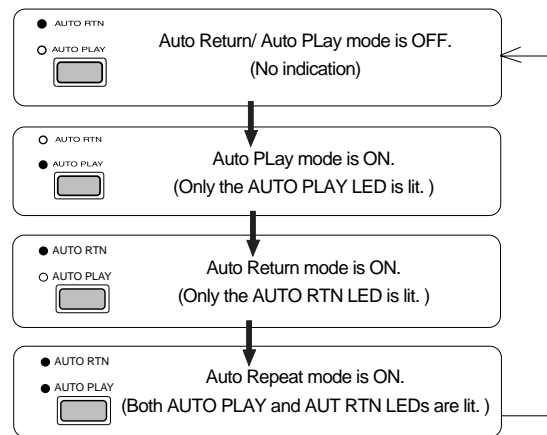

Auto Play mode:

In this mode, playback will start automatically after the START point is located. This function is effective at any locate points other than the REC END point.

Auto Return mode:

When the END point is reached during playback, the START point is automatically located in this mode. This function is effective only when the START and END points have been specified.

<Note>
 The Auto Return function works only during playback. In the recording mode, the START point will not be located automatically when the END point is reached.

Auto Repeat mode:

This mode is a combination of Auto Play and Auto Return, and plays back the part between the START and END points repeatedly. The auto repeat function is effective only when the START and END points have been specified correctly.

* Refer to page "57" for details.

5. Clipboard In key [CLIPBOARD IN]

This key is used to store and recall the In point (CLIPBOARD IN point) for the Copy or Move operation. You can locate a stored CLIPBOARD IN point. If you press the CLIPBOARD IN key while holding down the SHIFT key when the recorder is stopped, you can preview the fade-in part at the stored CLIPBOARD IN point.

- * Refer to page "66" for copying/moving data.
- * Refer to page "57" for locating the CLIPBOARD IN point.
- * Refer to page "63" for previewing data at the CLIPBOARD IN point.

6. Clipboard Out key [CLIPBOARD OUT]

This key is used to store and recall the Out point (CLIPBOARD OUT point) for the Copy or Move operation. You can locate a stored CLIPBOARD OUT point. If you press the CLIPBOARD OUT key while holding down the SHIFT key when the recorder is stopped, you can preview the fade-out part at the stored CLIPBOARD OUT point.

- * Refer to page "57" for locating the CLIPBOARD OUT point.
- * Refer to page "66" for copying/moving data.
- * Refer to page "63" for previewing data at the CLIPBOARD OUT point.

7. Auto Return Start key [AUTO RTN START]

This key is used to store and recall the start point (AUTO RTN START point) for the Auto Return or Auto Repeat operation. You can locate a stored AUTO RTN START point. If you press the AUTO RTN START key while holding down the SHIFT key when the recorder is stopped, you can preview the fade-in part at the stored AUTO RTN START point.

- * Refer to page "57" for locating the AUTO RTN START point.
- * Refer to page "66" for copying/moving data.
- * Refer to page "63" for previewing data at the AUTO RTN START point.

8. Auto Punch In key [AUTO PUNCH IN]

This key is used to store and recall the recording start point (AUTO PUNCH IN point) for the Auto Punch IN/OUT operation. This point is also used as an erase point. You can locate a stored AUTO PUNCH IN point. If you press the AUTO PUNCH IN key while holding down the SHIFT key when the recorder is stopped, you can preview the fade-out part at the stored AUTO PUNCH IN point.

- * Refer to page "39" for more information about Auto Punch In/Out recording.
- * Refer to page "66" for more information about pasting data.
- * Refer to page "70" for more information about the Erase operations.
- * Refer to page "63" for previewing data at the AUTO PUNCH IN point.

9. Auto Punch Out key [AUTO PUNCH OUT]

This key is used to store and recall the recording end point (AUTO PUNCH OUT point) for the Auto Punch IN/OUT operation. This point is also used as an erase point. You can locate a stored AUTO PUNCH OUT point.

If you press the AUTO PUNCH OUT key while holding down the SHIFT key when the recorder is stopped, you can preview the fade-in part at the stored AUTO PUNCH OUT point.

- * Refer to page "39" for more information about Auto Punch In/Out recording.
- * Refer to page "70" for more information about the Erase operation.
- * Refer to page "63" for previewing data at the AUTO PUNCH OUT point.

Memory keys (CLIPBOARD IN, CLIPBOARD OUT, AUTO RTN START, AUTO PUNCH IN, AUTO PUNCH OUT, and AUTO RTN END keys) have the following common functions:

- * Pressing a Memory key to recall the point the key is storing displays the memory data (time, or bar/beat/clock) currently stored in that key; then the recorder enters data edit mode. To edit data, use the SHUTTLE dial to move among the digits, and then use the JOG dial to change the value.
- * After you finish editing data, press the STORE key, and then press one of the Memory keys into which you want to store the point. The edited data will be stored in the specified Memory key.
- * While the current position of the recorder is indicated, press the STORE key, then one of the Memory keys into which you want to store the data. The current position of the recorder will be stored in the Memory key. You can do this while the recorder is running or stopped.
- * Press a desired Memory key, and then press the LOCATE key to locate the point stored in that Memory key (time, or bar/beat/clock).
- * In Setup mode, you can save or load song data for each Program.
- * All data will be retained after you turn off the power.

- * Refer to page "54" for more information on memory data.
- * Refer to page "57" for more information on the Locate function.
- * Refer to pages "21" and "36" for more information on the Program Change function.
- * Refer to page "84" for more information on saving and loading song data.

10. Auto Return End key [AUTO RTN END]

This key is used to store and recall the end point (AUTO RTN END point) for the Auto Return or Auto Repeat operation. You can locate a stored AUTO RTN END point. If you press the AUTO RTN END key while holding down the SHIFT key when the recorder is stopped, you can preview the fade-out part at the stored AUTO RTN END point.

- * Refer to page "57" for locating the AUTO RTN END point.
- * Refer to page "66" for copying/moving data.
- * Refer to page "63" for previewing data at the AUTO RTN END point.

11. Display Select key [DISP SEL]

This key is used to change the display mode. Pressing this key repeatedly will change the display mode as follows:

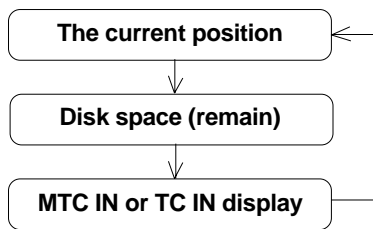

If an optional Model 8345 TC/SYNC card is installed, information in the MTC IN or TC IN will differ depending on [Ref. TC?] menu setting (MTC or LTC) in the SETUP mode. If the card is not installed, [00h 00m 00s 00f 00sf] will always be displayed.

- * Refer to page "24" in regards to REMAIN, page "101" on the SETUP menu, and the APPENDIX on details if the Model 8345 TC/SYNC card is installed.

Pressing this key while holding down the SHIFT key will switch the Time Base (*) as follows. The Time Base can be set when the display shows the recorder's current position or the available disk space (REMAIN).

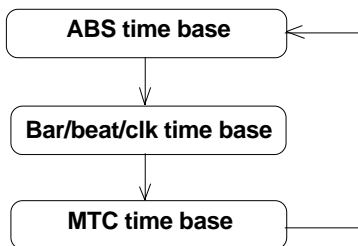

(*) Time Base:

The recorder uses time display (ABS or MTC) or Bar/Beat/Clock display to indicate the current position of the recorder section. These displays are called "Time Base." ABS (Absolute Time) shows the absolute time of the disk, and MTC (MIDI Time code) shows the relative time obtained by adding an MTC offset value to the ABS value. Bar/Beat/Clock (BAR/BEAT/CLK) indicates a position within a piece of music and conforms to the MIDI clock and Song Position Pointers created on the internal Tempo Map.

- * Refer to pages "23" and "105" for more information about MTC and the internal Tempo Map.

12. Program select key [PGM]

When this key is pressed, the mode will change to setup for a new program and allow program selecting.

- * Refer to page "35" for program select function.

13. Store key [STORE]

This key is used to store a time value (or Bar/Beat/Clock value) to one of the memory keys. Pressing this key, and then one of the following keys will cause the data shown on the display to be stored to the corresponding memory key you pressed.

STORE -> CLIPBOARD IN

Data is stored as a Clipboard In point. The stored data can be used as a locator.

STORE -> CLIPBOARD OUT

Data is stored as a Clipboard Out point. The stored data can be used as a locator.

STORE -> AUTO PUNCH IN

Data is stored as an Auto Punch In point. The stored data can be used as a locator.

STORE -> AUTO PUNCH OUT

Data is stored as an Auto Punch Out point. The stored data can be used as a locator.

STORE -> AUTO RTN START

Data is stored as an Auto Return Start point. The stored data can be used as a locator.

STORE -> AUTO RTN END

Data is stored as an Auto Return End point. The stored data can be used as a locator.

STORE -> ([Press LOCATE:]) -> LOCATE**

Using [Press LOCATE: **] displayed after pressing the RECALL key, data stored in the desired locate number (00~99) can be recalled.

After pressing this key, if you wish to cancel the store operation, press the EXIT/NO key, or STOP button.

- * Refer to page "57" for more information about the Locate function.
- * Refer to page "39" for more information about Auto Punch In/Out recording.
- * Refer to page "57" for more information about Auto Return.

14. Exit key/No key [EXIT/NO]

The opposite of the EXECUTE/YES key, this key is used to stop operation. When using a removable type SCSI device for backup, if the "Drive setting" in the SETUP mode is set to [SCSI6], the SCSI disk can be ejected by pressing this key while pressing on the SHIFT key when the SCSI disk is stopped.

* Refer to page "66" for more information about using this key for the Paste or Erase operation.
* Refer to page "101" for more information about using this key in SETUP mode.

15. Execute/Yes key [EXECUTE/YES]

Press this key to execute the operation when you edit data on the hard disk using the edit functions such as Paste and Erase, when you put the recorder into SETUP mode, or when you set the parameters in the SETUP menu.

Pressing this key while holding down the SHIFT key allows you to select the Slave mode on/off.

* Refer to page "66" for more information about using this key for the Paste or Erase operation.
* Refer to page "101" for more information about using this key in SETUP mode.
* Refer to page "74" for more information about using this key for the Slave Mode operation.

16. Recall key [RECALL]

This is pressed to call out the time figure (or bar/beat/clock figure) data stored in locate number (0-99). If the LOCATE key is pressed after pressing this key, the RECALL LED will light and [Press LOCATE**] is displayed. Next, by pressing the LOCATE key after specifying a desired locate number, the time figure in memory will be recalled into the specified number and the recorder will enter the edit mode.

Press the LOCATE key to execute this time figure.

* Refer to page "57" for more information about using this key for the Locate operation.

17. NEXT key [NEXT]

If this key is pressed when in the recorder is in the PLAY/STOP/F FWD or REW mode, locate will be executed to the next memory point from the present location point.

When inputting characters in the title edit mode, it serves as a character short cut function.

The memory number can be advanced with each press of this key when the recorder displays [Press LOCATE: **].

18. PREVIOUS key [PREV]

If this key is pressed when the recorder is in the PLAY/STOP/F FWD or REW mode, locate will be executed to the one previous memory point.

When inputting character in the title edit mode, this serves as a character short cut function.

The memory number selecting during display of [Press LOCATE: **], the memory number can be reverted with each press of this key.

19. Jog/Shuttle dial**Jog dial (inside):**

Turning the JOG dial while the recorder is stopped performs digital scrubbing in either direction, which allows you to check the audio and locate a point without any change in pitch.

The JOG dial is also used to change values in the data edit mode or when the pitch data is displayed. It also allows you to select a parameter to set in Setup mode.

Shuttle dial (outside):

FWD and REW direction shuttle operation in the STOP mode is possible at +/-1 ~ 64times fast winding in the no sound state. On the other hand, FWD and REW direction shuttle operation in the PLAY mode is possible in the CUE playback mode at +1 ~ 8 and -1 ~ -7 times speed while cueing. In addition, while in the display edit mode, the editing point can be moved.

* Refer to page "54" for more information about the editing the memory data.
* Refer to page "101" for more information about SETUP mode.
* Refer to page "60" for more information about Digital Scrubbing.

20. Vari-pitch key [VARI PITCH]

Use this key to turn the Vari-pitch function on and off. When this function is enabled, the corresponding LED lights up. When this function is disabled, the LED turns off. The range of pitch variation for playback and recording is +/-6.0%, in 0.1% steps. Press the SHIFT key, and then the VARI PITCH key to display the current pitch data.

To change the pitch data, use the JOG dial to change the value while the pitch data is displayed.

You can also change the playback speed when the data is being played back with the Vari-pitch function ON. To quit the pitch data display, press the EXIT/NO key, or the STOP button.

<Notes>

* Even if the pitch data is 0.0% (no speed change), pressing the VARI PITCH key will still turn on the VARI PITCH function. The speed is not changed, but the Vari Pitch is turned on.

* The Vari Pitch function will automatically turn off under the following conditions:

1. You have turned off and on the power to this recorder. The pitch data will be reset to 0.0%.
2. You have pressed the EXECUTE/YES key while holding down the SHIFT key to turn the "SLAVE mode" on (the setting pitch data remains).
3. You set "Digital In" of the SETUP mode to a SYNC mode ("SPDIF :Sync" or "adat :Sync") and the recorder is locking to the external clock from DIGITAL IN or WORD IN. In consequence, [DIGITAL] and [EXT SYNC] indicators light in the display.
4. You have installed the optional Model 8345 TC/SYNC card in this recorder and set the LTC OUT to [Gen.].

* Refer to "Quick Operation Guide" for more information on the Vari-pitch function.
* Refer to pages "79" and "82" for more information on Slave mode.

21. Fast Forward button [F FWD]

Pressing this button while the recorder section is stopped will fast forward data at 30 times speed. Pressing this button in Play mode will cue data (you can hear sound during the fast forward operation) at five times speed.

Pressing this button while holding down the STOP button will initiate the "LOCATE ABS REC END" operation, and immediately locate the end of the recorded data on the Program (ABS REC END). (Refer to the "STOP button" section for more information about LOCATE ABS REC END.)

22. Locate key [LOCATE]

Use this key to start to start the LOCATE feature. Pressing this key after a memory key (CLIPBOARD IN/OUT, AUTO RTN START/END, AUTO PUNCH IN/OUT) locates the memory data programmed in each respective key (time mode or bar, beat, clock setting). The data can be programmed by individually setting it with one of the 99 (01-99) LOCATE numbers of the LOCATE key.

Note that the data of memory number 00 is available in addition to LOCATE numbers 01-99. The last LOCATE time setting (bar, beat, clock setting) constantly replaces the data stored in the LOCATE key as data in memory number 00. Therefore, it is possible to press this key alone to repeatedly LOCATE the same point.

These data can be individually stored in programs P1-P99. The data for each program is SAVED or LOADED for each program when the song data is designated for SAVE/LOAD in the SETUP mode. This data is maintained even when the power is turned OFF.

** Refer to page "57" for more information about the Locate function.*

23. Rewind button [REWIND]

Pressing this button while the recorder section is stopped will rewind data at 30 times speed.

Pressing this button in Play mode will cue data (you can hear sound while rewinding) at five times speed. Pressing this button while holding down the STOP button will perform the "LOCATE ABS 0" operation, and immediately locate the beginning of the Program (ABS TIME: 00m: 00s: 00f). (Refer to the "STOP button" section for more information about LOCATE ABS 0.)

24. Undo/Redo key [UNDO/REDO]

If you wish to restore the status prior to editing, recording, or performing a punch in/out take, press the UNDO/REDO key. Pressing the UNDO/REDO key again will return you to where you were before you pressed the UNDO/REDO key the first time.

If the current drive you are using has been formatted with the multiple undo function switched ON, you can execute multiple undo by pressing this key while holding down the SHIFT key.

<Note>

This key is enabled only when the recorder is stopped.

- * Refer to pages "42", "45", "68" and "71" for more information about the single Undo/Redo operation.*
- * Refer to page "64" for more information about Multiple Undo function.*

25. Play button [PLAY]

Pressing this button will cause the recorder to play back. Pressing this button while holding down the RECORD button will start recording.

Pressing this button while holding down the STOP button will perform the Clipboard playback operation. Refer to the section "STOP button" for more information on the Clipboard playback.

Pressing the PLAY button during recording will stop recording.

26. Setup key [SETUP]

Press this key to puts the recorder in the SETUP mode to execute various operations. This key works when the recorder is stopped. To exit from the SETUP mode, either press the EXIT/NO key or the STOP button. If the optional Model 8345 TC/SYNC card is installed and external time code is being input, you can enter the generator setup mode by pressing this key while pressing on the SHIFT key.

- * Refer to page "101" for more information on SETUP mode.*
- * Refer to "APPENDIX" for more information about generator setup mode.*

27. Stop button [STOP]

Pressing this button will stop the transport section of the recorder. Pressing the PLAY, REWIND, or F FWD button while holding down this button will cause the recorder to perform the following operation:

STOP button + PLAY button
Clipboard playback (The STOP LED will flash and the PLAY LED will light up.) *1
STOP button + REWIND button
Locate ABS 0 *2
STOP button + F FWD button
Locate REC END *3

Pressing the STOP button will abort the editing operations and display the current position of the recorder, if you wish to:

- * quit the data edit mode,*
- * cancel the recall or store operation,*
- * quit the pitch data display,*
- * cancel the edit operation, such as pasting, or*
- * cancel the SETUP menu settings.*

Pressing the foot switch while holding down this button allows you to turn the punch in/out rehearsal mode ON/OFF.

***1 Clipboard playback:**

The recorder plays back the copy data or move data for the Clipboard. During audio playback of the copy or move data, the FL will display the time length and data type ("Copy Clip Play!" or "Move Clip Play!"), and the copy or move source track indicator will flash, enabling you to quickly determine the track and data type.

***2 Locate ABS 0:**

The recorder will locate the top of the selected Program (ABS TIME: 00m: 00s: 00f).

***3 Locate REC END:**

The recorder will locate the end of the recorded data on the Program (ABS REC END).

These operations can be executed only on real tracks.

- * Refer to page "23" of the "Before Starting" section for more information about ABS 0 and ABS END.
- * Refer to page "43" for more information about Punch In/Out recording using the foot switch.
- * Refer to page "67" on details for "Clip board play."
- * Refer to page "57" on details for "LOCATE 0" and "LOCATE REC END."

28. Edit key [EDIT]

Pressing this key enters the recorder to the menu select mode for editing tracks. Press this key repeatedly or turn the JOG dial to select menu.

Edit menus appear in the following order. To execute a desired menu, select the menu, then press the EXECUTE/YES key. To exit the selection mode, press the EXIT/NO key.

If the optional Model 8345 TC/SYNC card is installed, you can enter the TC READY mode for recording time code by pressing this key while pressing on the SHIFT key.

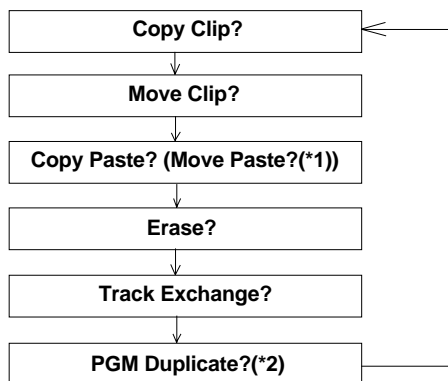

(*1): After you execute copy clip, "Copy Paste" appears. After you execute move clip, "Move Paste" appears.

(*2): The program duplicate display will appear only if the current drive was set to ON for the "Multiple Undo Function" when formatting. If the current drive is set to OFF, the program duplicate display will not appear even if the EDIT key is pressed.

- * Refer to page "66" for more information about "Copy Clip," "Move Clip," "Copy Paste," "Erase," and "Track Exchange."
- * Refer to page "35" for more information about program duplicate function.

<Note>
* This key is enabled only when the recorder is stopped.

29. Record button [RECORD]

Pressing only this button places the readied tracks into input monitoring status. Pressing this button again will reset the tracks to playback monitoring. (The RECORD LED will blink when the readied tracks are in input monitoring status.)

Pressing the PLAY button while holding down this button will place the readied tracks into recording. At this time, the PLAY LED and RECORD LED will light, and the readied track indication will be light steadily (instead of blinking).

- * Refer to page "27" of the "Before Starting" section for more information about input monitoring and reproduce monitoring.

30. Auto Punch Mode On/Off key [AUTO PUNCH]

Switch this key ON for auto punch in/out. When you press this key while a correct value is stored to the AUTO PUNCH IN key and the AUTO PUNCH OUT key, both the REHEARSAL LED and TAKE LED will blink, indicating that Auto Punch mode is on. (If a correct value is not stored, pressing the AUTO PUNCH key will not turn the parameter ON, and the message "Void Out Point!" will appear.)

Pressing the PLAY button under this condition will put the recorder into "Rehearsal mode" for Auto Punch In/Out recording. Pressing the PLAY button and RECORD button simultaneously will put the recorder into "Take mode."

There are five combinations of the REHEARSAL LED and TAKE LED that indicate the status of the recorder regarding auto punch recording:

Auto Punch mode OFF
Both REHEARSAL LED and TAKE LED are off.
Auto Punch mode ON
Both REHEARSAL LED and TAKE LED are blinking.
Auto Punch TAKE mode
Only the TAKE LED (red) is lit.
Auto Punch REHEARSAL mode
Only the REHEARSAL LED (green) is lit.
Rehearsal mode entered by means of MMC or foot switch
Only the REHEARSAL LED (green) is blinking.

<Note>

If a correct value is not stored, pressing the AUTO PUNCH key will not enable the function, and the message "Void Out Point!" will appear. If a correct value is not stored, pressing the AUTO PUNCH key will not turn on the function, and the message "Void Out Point" will alert you. In this case, set a correct value for the Auto Punch In/Out point. Also, the function is not turned on when you press the AUTO PUNCH key if the disk does not have enough recording space. The display will indicate "_**h**m**s**f Over."

- * Refer to page "101" for details on the SETUP mode.
- * Refer to the APPENDIX at end of this manual in regards to the TC generator mode.
- * Refer to page "64" for details on multiple undo function.
- * Refer to the Quick Operation Guide in regards to editing of Vari Pitch data.
- * Refer to page "63" for details on preview.
- * Refer to page "60" for details on the envelope function.

<Note>

Ejecting or removing the backup SCSI disk is only possible when the drive is set to [SCSI 6] via the SETUP mode "Setup of the drive." If the drive is set to [IDE], eject it using the SCSI drive EJECT switch.

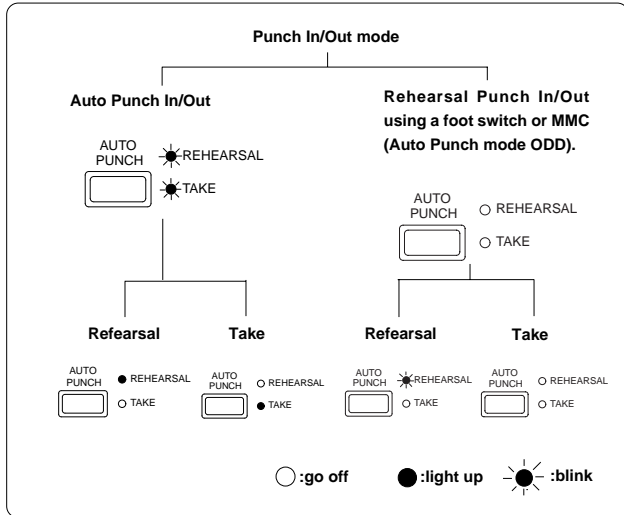

* Refer to page "39" for details about Punch In/Out operation.

31. Shift key [SHIFT]

Press a key, or button while holding down the SHIFT key to activate the following "shift-invoked" functions.

Key with SHIFT function	Function
RECORD TRACK SELECT keys	Executes the envelope function of the selected track.
TRACK SHIFT key	Switches ON/OFF of the input monitor for all tracks.
RECORD button	Switches SAFE-READY for all tracks.
CLIPBOARD IN/OUT key	Executes preview of the stored point of each memory key.
AUTO PUNCH IN/OUT key	
AUTO RTN START/END key	
EXIT/NO key	Ejects disk in the external SCSI drive. Please see <Note> below.
EXECUTE/YES key	Switches the slave mode ON/OFF.
DISP SEL key	Selects the time base.
EDIT key	Switches TC READY ON/OFF.
SETUP key	Enters the TC GEN setup mode.
UNDO/REDO key	Enters the multiple undo executing mode.
VARI PITCH key	Enters the vari pitch data editing mode.

32. Time code ready LED [TC READY]

When an optional Model 8345 TC/SYNC card is installed in the recorder and external time code or internal TC generator time code is to be recorded, if the EDIT key is pressed while holding down the SHIFT key, the recorder will enter the TC READY mode and the LED will blink. When time code recording starts, it will change from blinking to lit.

* For details, refer to APPENDIX at end of this manual.

33. Hard disk access LED (green)

This LED lights up or blinks when the hard disk is writing or reading data.

<CAUTION>

Do not turn the power off while this LED is lit or blinking. Otherwise, data on the hard disk may be damaged.

34. All input LED (ALL INPUT)

This lights when the TRACK SHIFT key is pressed while holding down the SHIFT key and the input monitor is switched ON for all tracks, and will extinguish when switched OFF.

35. Punch In/Out jack [PUNCH IN/OUT]

(Connector: PHONE jack)

Connecting the optional foot switch will let you control punch In/Out (and rehearsal) recording. Use a Fostex Model 8051 foot switch.

* Refer to page "43" for information about Punch In/Out recording using the foot switch.

<Note>

Be sure to use an "unlatch type" foot switch if you use a foot switch other than the Model 8051. Otherwise, a malfunction could occur.

36. Meter display

This meter display shows the signal level and settings.

* Refer to the "Display section" on page "19."

Rear panel section (D824)

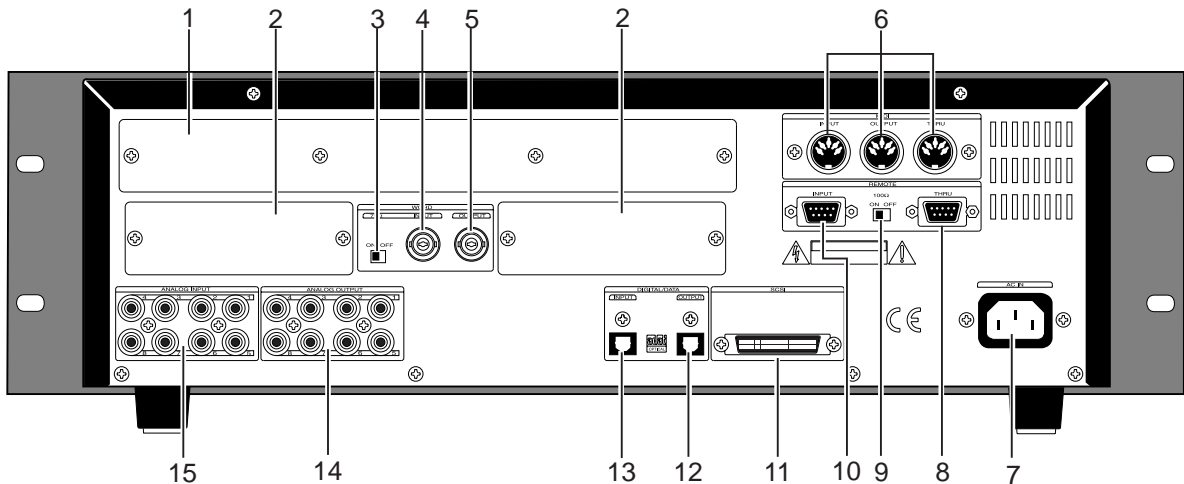

Rear panel section (D1624)

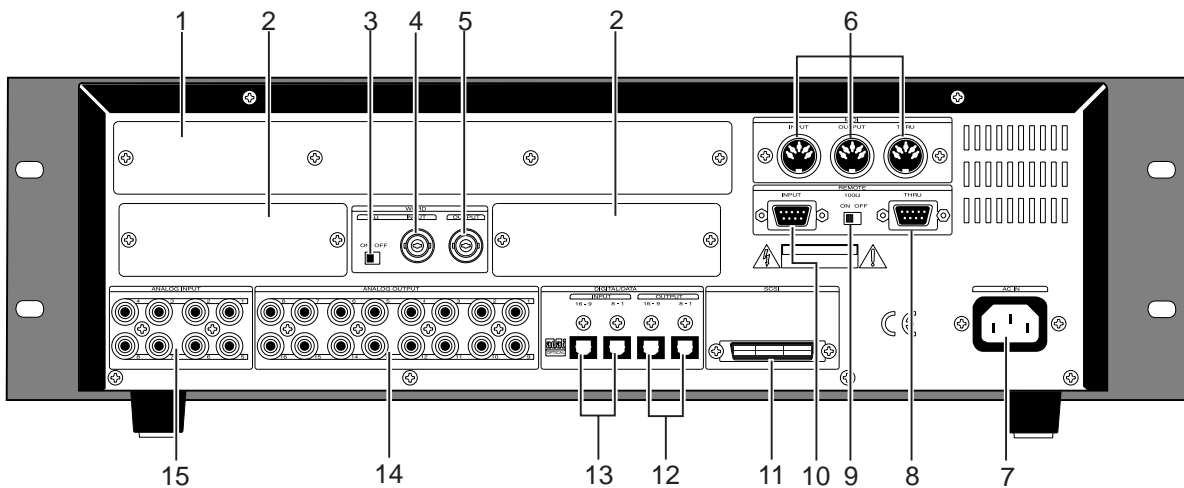

1. Panel A for an optional card

[When using the D824]

This is the panel used for installing the optional Model 5042 (balanced 8-8 I/O card), and the optional Model 8350 (8-8 I/O AES/EBU card). In general, leave the panel in place if these are not installed.

[When using the D1624]

This is the panel used for installing the optional Model 5043 (balanced 8-16 I/O card), or the optional Model 8350 (8-8 I/O AES/EBU card x 2). In general, leave the panel in place if these are not installed.

<Note>
 Model 5043 and Model 8350 (x 2) cannot be installed at the same time.

2. Panel B for an optional card

This is the panel used for installing the optional Model 8345 (TC/SYNC card). The Model 8345 gives the recorder have LTC input and output connectors. Also, the sync lock with video sync will be possible. In general, leave the panel in place if this is not installed.

<Note>
 The options must be installed by a Fostex Service Station. For details, please inquire at your nearest Fostex Service Station.

3. WORD IN terminating switch

This is the WORD IN port terminating switch (75Ω). Turn this ON when inputting an external word clock signal into the WORD IN connector from digital equipment.

4. WORD INPUT connector (Connector: BNC)

Word clock signal from external digital equipment is input here for the purpose of phasing with external digital equipment.

5. WORD OUTPUT connector (Connector: BNC)

Word clock signal from the recorder is output to external digital equipment.

6. MIDI Input/Output/Thru connector

[MIDI INPUT/OUTPUT/THRU] (connector: DIN 5-pin)

MIDI INPUT:

Connect the MIDI OUT connector of an external MIDI device here. The recorder can be controlled remotely via an external MMC (MIDI Machine Control) or FEX (Fostex System Exclusive Message).

MIDI OUTPUT:

Connect the MIDI IN connector of the external MIDI device here. The recorder will output MTC (MIDI Time Code), MIDI Clock signal, MMC (MIDI Machine Control) response, and FEX (Fostex System Exclusive Message) response.

MIDI THRU:

This connector outputs the input signal at the MIDI INPUT connector without modification. When using multiple recorders via MIDI, connect this terminal to the MIDI INPUT connector of the second recorder.

7. AC IN connector

The power cable packaged with this recorder is connected here.

<Note>

Always plug the power cable to the recorder before plugging the cable into the wall outlet.

8. REMOTE THRU connector

RS-422 control signal (SONY 9PIN PROTOCOL or Fostex System Exclusive Message) input from the REMOTE INPUT connector is output here. This is connected to the second recorder REMOTE INPUT when controlling a multiple number of recorders.

9. REMOTE INPUT terminating switch

This REMOTE INPUT terminating switch (100Ω) is switched ON for normal use of an inputted RS-422 control signal into the REMOTE INPUT connector. When controlling a multiple number of recorders, the last one only is switched ON; the others are switched OFF.

10. REMOTE INPUT connector

External RS-422 control signal (SONY 9PIN PROTOCOL or Fostex System Exclusive Message) is input here to control this recorder.

11. SCSI connector [SCSI]

(connector: half-pitch 50-pin)

Connect a backup SCSI device to SAVE/LOAD data. Up to one SCSI devices can be connected to the SCSI connector.

* Refer to page "90" for more details on SAVE/LOAD using a SCSI device.

12. Digital/Data Output connector

[DIGITAL/DATA OUTPUT]

(connector: OPTICAL)

Use this connector to save song data (audio + setup data) from the unit to an external device. It is also used to output S/P DIF digital signal or adat digital signal to an external digital device.

* Refer to page "84" for information about "LOAD" function.

* Refer to page "46" for information "Digital Recording."

13. Digital/Data Input connector

[DIGITAL/DATA INPUT] (connector: OPTICAL)

Use this connector to load song data (audio + setup data) from an external device to the recorder. It is also used to input S/P DIF digital signal (from a DAT, CD, or MD) or adat digital signal.

* Refer to page "84" for information about "LOAD" function.

* Refer to page "46" for information "Digital Recording."

14. Analog Output jack (connector: RCA pin)

[When using the D824]

The D824 outputs analog audio signal here. Connect this jack to the TAPE IN connector of the mixer.

[When using the D1624]

The D1624 outputs analog audio signal here. Connect this jack to the TAPE IN connector of the mixer.

<Note>

In the D1624 is formatted in 96kHz/24bit, only outputs 1-8 will function.

15. Analog Input jack (connector: RCA pin)

[When using the D824]

Rout the analog audio signal from the mixer here. Connect this jack to the Group out (BUSS OUT) connector of the mixer.

Signals input to INPUT 1-8 are sent to tracks 1-8, and the track to be recorded is selected using the RECORD TRACK select key.

[When using the D1624]

Rout the analog audio signal from the mixer here. Connect this jack to the Group out (BUSS OUT) connector of the mixer.

Signals input to INPUT 1-16 are sent to tracks 1-16, and the track to be recorded is selected using the RECORD TRACK select key.

<Note>

In the D1624 is formatted in 96kHz/24bit, only inputs 1-8 will function.

Display section

The recorder display integrates the level meter of a high-visibility FL tube with a 16 digits and 35 dot message display. The level meter shows the Track 1-8 (or 1-16) output level of the recorder section. The time display shows the current time of the recorder section using ABS TIME (Absolute time), MTC (MIDI time code), or MIDI BAR/BEAT (bar/beat). This display also shows messages required for interactive operation. The following section explains the display functions and provides with some examples.

1. Display shown when the power is turned on

When you turn on the power to the recorder and the connected E-IDE hard disk (a formatted hard disk), the display shows the [Initializing...] message, [Current Dr], the name of the connected current drive, then recording mode (Standard format, etc.), and finally the top position of the disk in the time base (ABS, MTC, or BAR/BEAT/CLK) used in the last Program before you turned the power off.

The following example indicates that the recorder started with the ABS Time Base used in Program 1.

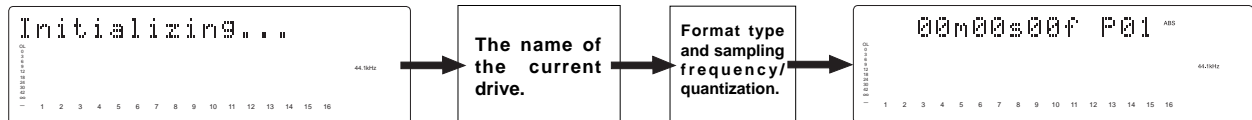

2. Preset Display

The display below shows all preset items for explanation purpose.

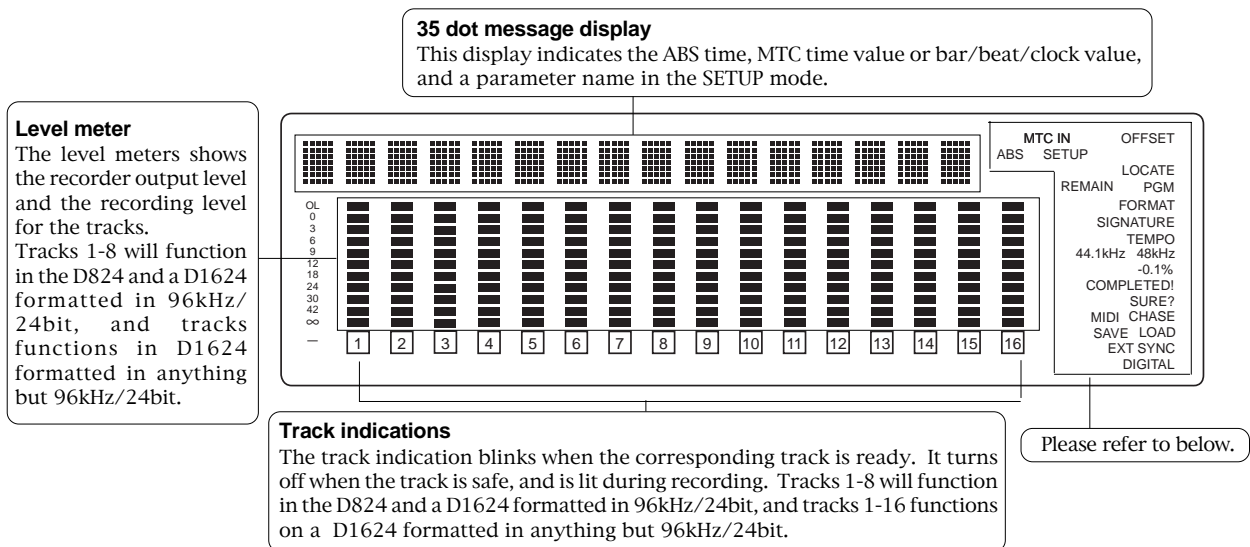

ABS	Lights up when ABS is selected as Time base.
MTC	Lights up when MTC is selected as Time Base.
SIGNATURE	Lights up to indicate a bar/beat/clock value when BAR/BEAT/CLK is selected as Time Base.
LOCATE	Lights up when the recorder enters data edit mode, enabling you to edit data. Pressing the LOCATE key while this indicate is lit will cause the recorder to locate the position of the displayed time or the bar/beat/clock value.
REMAIN	Lights up to indicate available recording time and space on the disk.
MTC IN TC IN	With the optional Model 8345 TC/SYNC card installed, this will be lit when MTC or LTC is externally input.

MTC OFFSET	Lights up when MTC OFFSET menu is selected in SETUP mode.
CHASE	Flashes when "Slave mode" is turned on. When a signal is locked, the flashing indicator lights up steadily.
PGM	Lights up to indicate the current program number.
TEMPO	Lights up when the tempo setting menu is selected in SETUP mode.
44.1kHz 48kHz	This displays the sampling rate of the current drive disk.
SURE?	This message is shown to confirm whether or not you wish to execute a certain operation.
COMPLETED!	This message indicates that an operation such as copy, move and paste has been completed.

MIDI	This indication lights up when the recorder receives effective MIDI message from an external MIDI device.
SAVE	When the recorder enters save function mode, the selected parameter name will appear here.
LOAD	When the recorder enters load function mode, the selected parameter name will appear here.
DIGITAL	This lights when a digital input track is set and a digital signal is correctly input. It will blink if the digital signal is not correctly input.

EXT SYNC	<p>In other than [Int.], if the SETUP mode [Clock Sel ?] menu is set to ([Auto], [Word], [Video]) and:</p> <ul style="list-style-type: none"> * data is loaded from adat/DAT, - * the digital-In is set to [adat: Sync] or [SPDIF: Sync], - * the SETUP mode Slave Type is set to [Vari] and Slave mode is set to ON, - <p>this will blink and change to constant lighting when the digital signal is correctly input.</p>
-----------------	---

3. Switching the display using the DISP SEL key.

Let's assume that you turned off the power while the time display was using a time base of "ABS," and then you turned the power on again. The recorder time display will again use a time base of "ABS." (Underline->Displayed program number)

ABS TIME display

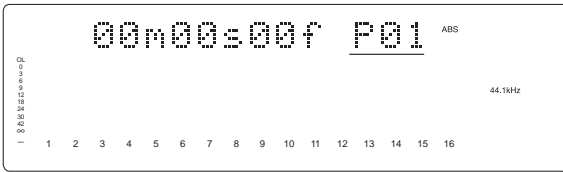

At this time if you press the DISP SEL key, the Disk Remain display will appear. (Both recordable time and hard disk capacity remaining will be converted to mono track and expressed in time and megabytes.)

DISK REMAIN display

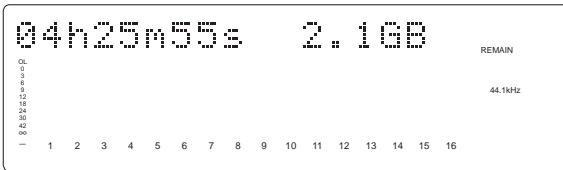

If "BAR/BEAT/CLK" is selected for the time base (explained later), the DISK REMAIN indication will show a value (in terms of the number of measures) calculated based on the last beat/tempo data on the tempo map of the recorded song.

If you press the DISP SEL key again, the MTC IN display will appear. If an optional Model 8345 TC/ SYNC card is installed, and the reference TC is switched to [LTC], and an external TC is input, that reference input LTC time figure will be displayed.

MTC IN display

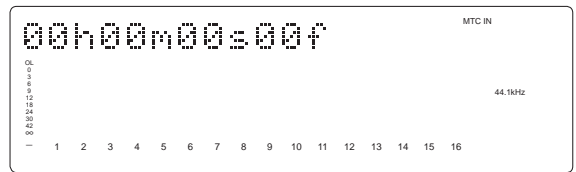

If you press the DISP SEL key again, the screen will return to the "ABS TIME" display.

4. Switching the Time Base display using the SHIFT key and DISP SEL key

When the screen is showing the ABS TIME or REMAIN display, if you press the DISP SEL key repeatedly while holding down the SHIFT key, the TIME BASE display will change cyclically. You can select one of the following Time Base displays.

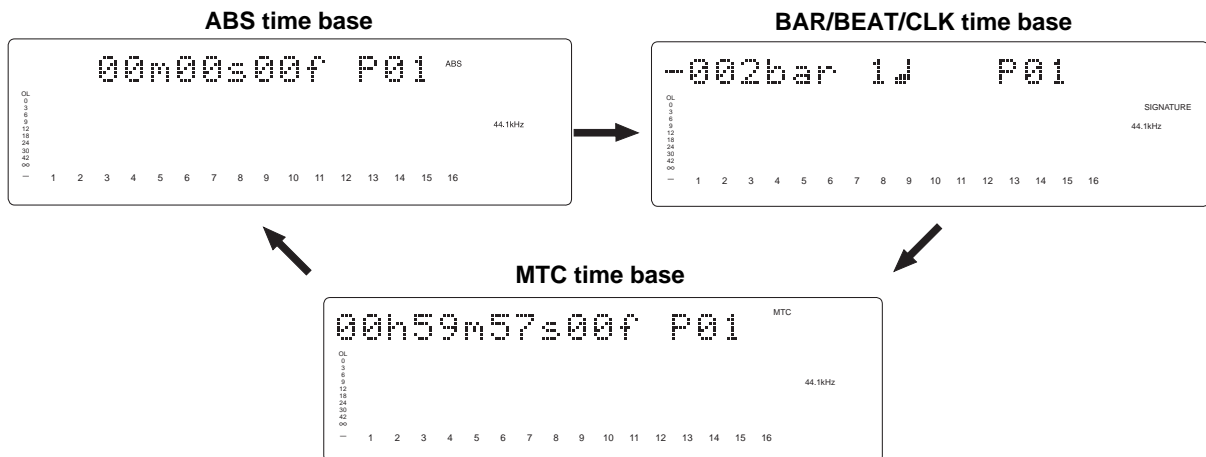

5. Changing Programs using the PGM key

* About the Program Change function

The Program Change function divides the hard disk space into up to 99 parts to accommodate 99 separate Programs (P01-P99 — as long as available recording time allows) so you can record, play back, edit, and retrieve (save and load) data for each Program individually.

For example, the first song can be Program 1, the second song can be Program 2, etc. You need to recall the desired Program before you start recording, playback, editing, or retrieving.

Pressing the PGM key will cause the recorder to enter Program select mode, display the message “Select PGM !”, followed by the current Program and Program number and a flashing “SURE?” indication.

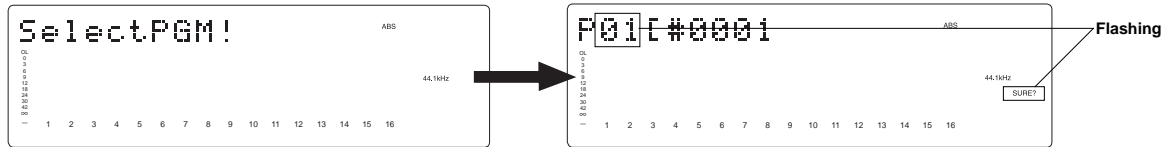

You can select the desired Program from the already setup Programs by rotating the JOG dial while the Program number and “SURE ?” are flashing. (“#0001” is the current program title.)

After you select a Program, press the EXECUTE/YES key to return to the selected Program’s ABS indication.

The Time Base display will indicate the selected Program’s Time Base, since you can set the Time Base for each Program individually.

To change the Time Base display after you have selected the desired Program, press the DISP SEL key while holding down the SHIFT key.

Pressing only the DISP/SEL key will take you to the REMAIN display based on the current Time Base.

<Notes>

* The maximum record time of the program is dependent on the permissible record time (size) of the hard disk, regardless of how many programs are created on the disk. If, for example, there is roughly 30 minutes of record time remaining (REMAIN) on the current drive immediately after it is formatted, and a 20 minute program is recorded in Program 1, then there is only 10 minutes of recording time remaining for any additional programs. Simply put, if the total record time is 30 minutes it does not matter whether the 30 minutes is taken by 1 program or shared among several programs, since the total of 30 minutes for a recording remains the absolute total. Note that some disk space is compensated when several programs are created on the disk. A new program cannot be created when there is no recordable space remaining on the disk. However, programs produced by "Program duplicating" are exempted.

* For initial setup, when producing a new program, the initial setting of the currently active program is directly copied. will For example, if there is a randomly set tempo map in the current program, that tempo map setting will be copied as the tempo map for the new program. This is convenient for producing a new program with the same setting as previously made music.

6. Warning messages

If you perform an incorrect operation, input incorrect data, or if an error occurs, the following alarm indication appears:

Invalid data indication:

The input data is not appropriate for the operation.



Action to take:

Input correct data.

Display of void:

This is displayed if you attempt some sort of process for which the optional Model 8345 TC/SYNC card is necessary and is not installed.

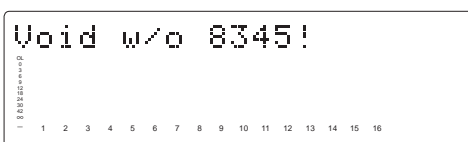

Invalid In/Out indication:

The In or Out point is not appropriate for the operation.



Action to take:

Input correct data.

Overtime indication:

Available disk space is insufficient for the length of time (the number of measures) indicated on the display.)



Action to take:

During the copy & paste and move & paste operation, try to shorten the length of the copied data by the indicated amount. Alternatively, use the "ERASE" function to move the ABS END point backward to obtain enough disk space for editing.

<Note>

Optimizing the disk is necessary in the current drive in which multiple undo is ON.

Unassigned track indication:

Select any track.

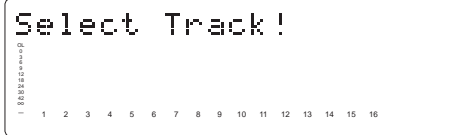

Action to take:

Use the RECORD TRACK select key to ready any track.

Event overflow indication:

The editing points have overflowed.



Action to take:

After temporarily saving the data to an external SCSI via the SETUP mode "SAVE" menu, return the data to the recorder by the same SETUP mode "LOAD" menu. The editing number of points will be cleared and you can continue editing.

Load error indication:

You cannot load data because the data input to the DATA INPUT connector contains an error.

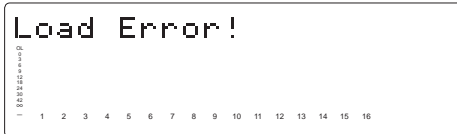

Action to take:

Check to see if there is an abnormality with the external digital machine connected to the DATA INPUT connector, or cable. Try to "LOAD" again.

Un-formatted indication:

The internal hard disk is damaged or not formatted yet. After this message is shown for about 10 seconds, "Disk Format ?" in Setup mode will flash on the display.



Action to take:

Press and hold down the RECORD button and press the EXECUTE/YES key to format the disk. (All audio and other data on the disk will be lost.)

Disk error indication:

This disk cannot be read.



Action to take:

Contact the Fostex service station as soon as possible.

Hard disk (E-IDE) connection error:

The hard disk is not connected correctly.



Action to take:

Correctly set the E-IDE hard disk again.

No disk error display:

This is displayed when the removable disk is incorrectly set in the SCSI device.

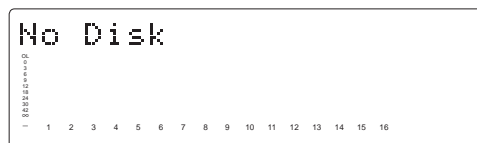

Action to take:

Reset the removable disk.

Recording Disable:

Recording is disabled.



Action to take:

Change the "Off" (recording) "Rec Protect ?" setting in Setup mode.

Before Starting

This chapter describes some basic items that you need to know before you start operating the recorder. All users, including those who are familiar with using tape-based multitrackers and those who are new to multitrackers, should read this chapter thoroughly to understand the functions of the recorder.

1. Time Base
2. Recording method and REMAIN indicator
3. Managing songs by Program Change function
4. Real tracks and Additional tracks
5. Input monitoring and playback monitoring
6. Audio file and Event

Time Base

The word “Time Base” appears frequently in this manual. The concept of Time Base is similar to a “tape counter” on a conventional tape-based multitracker in that it indicates the precise position of the recorder transport section (the current position).

The recorder offers three types of Time Base: ABS (Absolute type), MTC (MIDI time code), and BAR/BEAT/CLK (bar/beat/clock). ABS indicates an absolute time on the disk. MTC indicates a relative time that is obtained by adding a certain value (MTC offset value) to the ABS value. BAR/BEAT/CLK indicates the position in a song created in the internal Tempo Map according to MIDI clock and Song Position Pointer. The following diagrams depict the relationship among these three types of the Time Base.

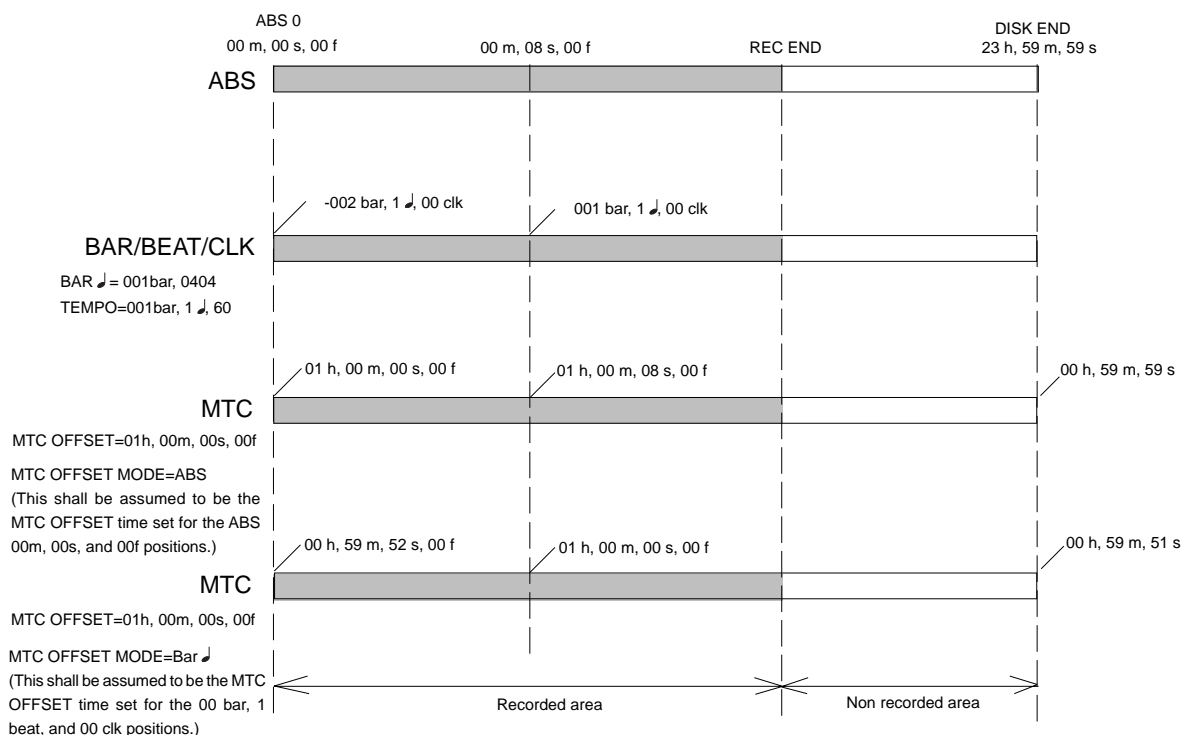

You can switch between these three types of Time Base to suit your purpose. (Refer to the explanation in “Display Section” on page “20” for more information on switching Time Base.)



<Note>

As shown in the figure, the ABS 0 position (top of the disk) is [-2 bar, 1 beat, 00 clk] (Time Base-BAR/BEAT/CLK). You can change this position in the ranged -9 bar to -2 bar in the “Setting the time signature” menu. Refer to the “Setting the time signature menu” section on page “103”.

Recording method and REMAIN indicator

Recording method

The recorder uses a E-IDE hard disk instead of a cassette tape. You can start recording sound sources from any point on a formatted disk as long as the point is within the range of 24 hours in ABS time, as described in the previous “Time Base” section. (Refer to the following diagram.)

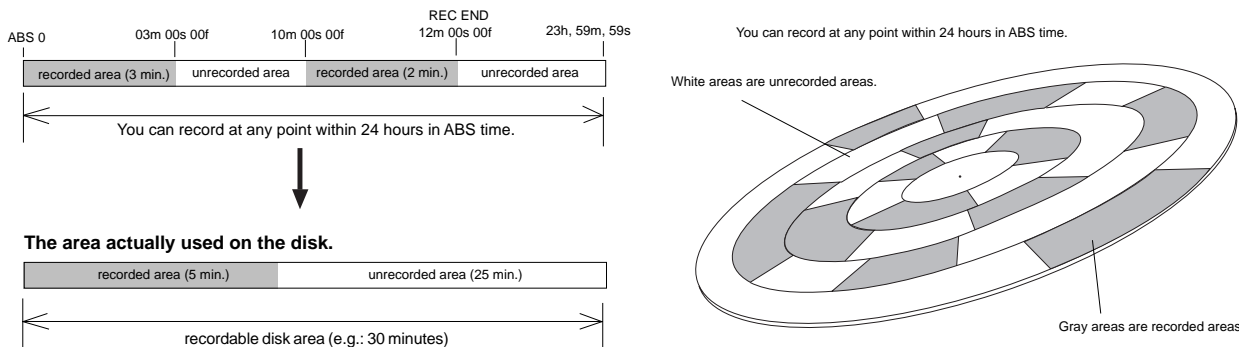

For example, if you record three minutes of data starting from ABS 0 (top of the disk) to ABS 03m 00s 00f on a disk that has a recordable space of thirty minutes, as shown in the diagram, then if you record two minutes starting at the 10-minute point in ABS time (ABS 10m 00s 00f) to ABS 12m 00s 00f, the recording end point (REC END) is 12 minutes (ABS 12m 00s 00f) in ABS time. However, this does not mean that the entire recording duration is 12 minutes. The disk space actually used for recording is five minutes (3 minutes + 2 minutes).

That is, the area between three minutes and ten minutes (that corresponds to 25 minutes of recording space) in terms of ABS time is still unrecorded.

When you try to play or fast forward this unrecorded area, the time counter on the display will count, but the recorder will not access the disk. However, MTC will be output when you try to play this area. On the recorder, the top of the disk is called “ABS 0” and the recording end point is called “REC END.”

REMAIN indicator

The REMAIN indicator displays available recording time expressed in time value (ABS or MTC) or bar/beat/clock (BAR/BEAT/CLK) value, depending on the currently selected Time Base.

It also indicates the available disk space. Right after you format the disk, the REMAIN indicator will show the maximum recordable time and space on the disk. The following example shows that the disk had about 20 minutes or 100MB recordable space after the disk format operation, and has recorded data of 4 minutes 27 seconds (or 19MB).

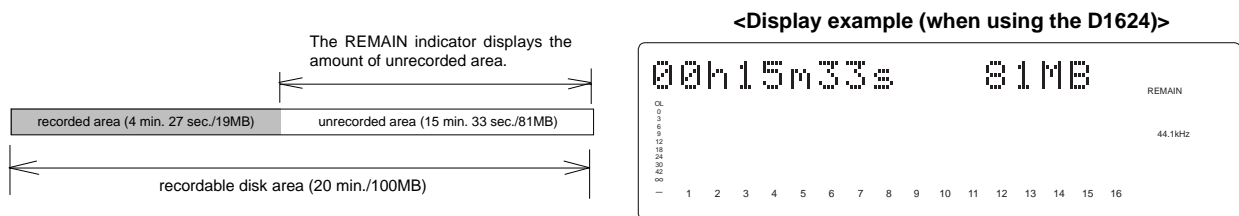

The REMAIN value is calculated on a mono-track basis. That value indicates the available recording time and space if you record on one mono-track.

For example, if you wish to know how much you can record on eight tracks, you need to divide the current REMAIN value by eight.

The REMAIN value display is calculated from data on the real track and data on the additional track which will be explained later, and includes data left over for multiple undo. In other words, the REMAIN value will be displayed in the form of time/capacity obtained by deducting data on the real track, data moved onto the additional track and past editing data left over for multiple undo.

As described in “Managing the song by Program,” the recorder can set up as many as 99 Programs on the disk. Setting up a Program requires a small amount of disk space. In other words, disk space is used not only for storing recorded data but also for storing all setup data. Therefore, make sure that you have enough space on the disk before you start recording to avoid running out of space (the [OVER !] message flashes in that case).

Managing songs by Program Change function

The recorder features Program Select function, which enables you to set up to 99 Programs on the disk.

When you format a disk, one Program will be automatically created on the disk. You may create more Programs, if necessary. You may also delete unnecessary Programs.

The recorder also features Program Change function that enables you to select one of the Programs set on the disk. Programs on the disk are something like independent containers. You can record, play, and edit each container without affecting other containers. You can also name Programs, which is useful for managing songs.

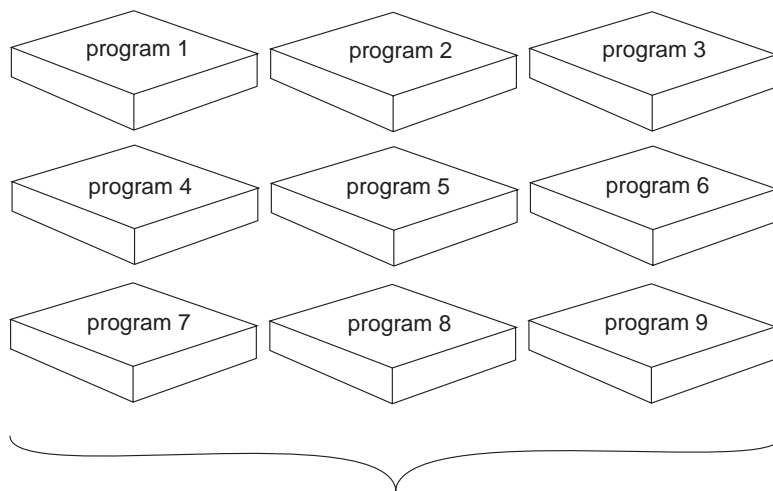

You can set up to 99 programs (independent containers).

<Display example (when using the D1624)>

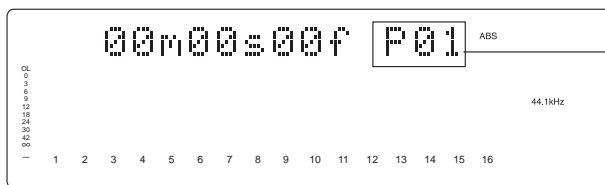

This is the Program indication when using an E-IDE hard disk as the current drive ([P] will appear before the program number such as [P01] shown in the example below).

- Refer to page “36” for more information on the program select function.
- Refer to page “36” for more information on the program delete function.
- Refer to page “37” for more information on the editing a program title.
- Refer to page “35” for more information on the duplicating a program.

<Note>
 Total available recording time is always the maximum available recording time on the disk, regardless of the number of Programs you set on the disk. That is, if you use up the maximum recording time for one Program, you will not be able to record any data in other Programs.

<Note>
 As described in the “REMAIN indicator,” creating additional Programs will consume a small amount of disk space.

Real tracks and Additional tracks

This recorder features Real Tracks (D824: Tracks 1-8, D1624: Tracks 1-16*) on which real time record/playback/edit is possible for one program and furthermore, features Additional tracks (D824: Tracks 9-26, D1624: Tracks 17-24).

The Real Track is normally used to record the sound source in real time and the Additional Track serves the purpose of temporarily storing sound recorded on the Real Track.

In other words, by temporarily moving data recorded on the Real Track to the Additional Track, other performances can be recorded on the cleared Real Track.

This recorder contains the “Track Exchange function” to make exchanges between the Real Track and the Additional Track. If this function is used between mono tracks, it will allow you to freely swap Real Track + Additional Track data between 24 tracks (tracks 1-24), and between multiple tracks, Real Tracks and Additional Tracks can be exchanged in 8 track units.

<When using the D824>

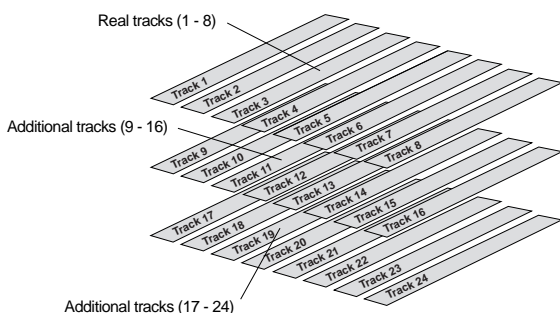

<When using the D1624>

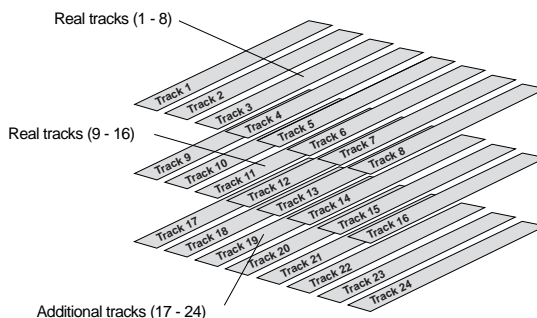

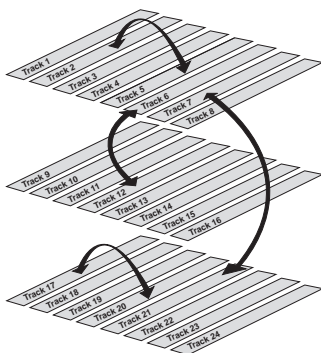

You can swap data between twenty-four mono tracks.



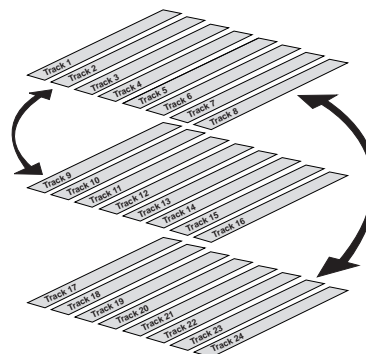

You can also swap data between real tracks and additional tracks in units of eight tracks.



<Note>
 You cannot record data on Additional tracks in real-time. Also, you cannot play back data on Additional tracks as is in real-time. If you wish to play back data on an Additional track, first use the Track Exchange function to move the data to a Real track. Also, you need to move the data to a Real track if you wish to check the REC END point of a song on an Additional track.

 Refer to page “72” for more information on the Track Exchange function.

<Note>
 Track composition of a D1624 formatted in 96kHz/24bit will be 8 Real Tracks + 16 Additional Tracks, the same as a D824.

<Note>
 Data on the Additional tracks also affects the REMAIN value. If Real tracks contain no data, but Additional tracks contain data, the amount of data (time and space) will be reflected in the REMAIN value.

<Note>
 If the record time of the data existing on the additional track is longer than the data on the real track and all tracks are saved on an external DAT or adat, then the data of the additional track can only be saved for the time equal to the real track, and the remaining data is not saved. This is because the ABS 0 to REC END of the real track is automatically recognized and saved. There is a need to exchange the track using the track exchange function in this case, as well.

Input monitoring and playback monitoring

There are two methods for monitoring track sound (only on the Real tracks): input monitoring and playback monitoring. They are defined as follows:

Input monitoring

Input monitoring means to listen to what is being input to the recorder so that you can verify sound quality and etc. Either one of the following procedure is used to input monitor any Real Track or all Real Tracks.

- **Entering any Real Track to input monitoring**

To enter any desired track for Input Monitoring, press the desired RECORD TRACK select key to enter it in the READY mode and then press the RECORD button. If the RECORD button is pressed again, the recorder will enter the repro mode. The recorder will enter record standby mode and the READY track only will be Input Monitoring. The recording level can now be adjusted.

- **Entering all Real Tracks to input monitoring**

To enter all Real Tracks to input monitoring, press the TRACK SHIFT key while holding down the SHIFT key. Unlike the previous case of selecting any desired track, Real Tracks can all be input monitored even though the RECORD button is not pressed. After adjusting the recording level, to simultaneously start recording all tracks, enter all tracks in the READY mode by pressing the RECORD button while holding down the SHIFT key.

- **Entering a track set to Input Monitoring to “recording mode”**

To enter the recording mode with any desired track or all tracks in the READY state, press the PLAY button while holding down the RECORD button. READY tracks will enter the recording mode, the READY track LED change to constant light and the RECORD LED will be lit. Simultaneous with entering the recording mode, READY tracks will be input monitoring and recording can be done while monitoring the recording sound at the recorder output.

* The following example shows track 5 in Input Monitoring mode and other tracks in Playback Monitoring mode.

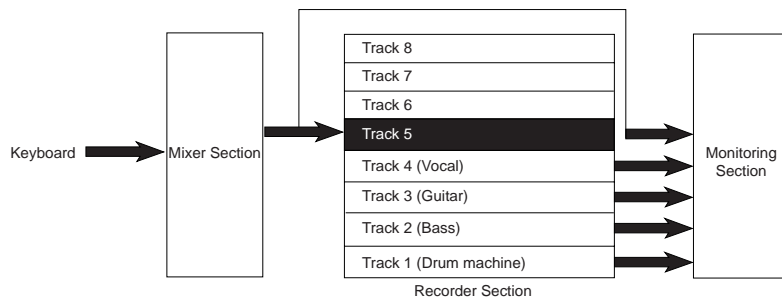

This example shows overdubbing in which the keyboard is recorded on track 5 while tracks 1-4 are being played. Tracks 1-4 are in Playback Monitoring mode and used to check the playback sound. Track 5 is in Input Monitoring mode. You can monitor the recorded sound.

Playback monitoring

“Playback monitoring” means to monitor the playback sound of the tracks (only Real tracks). That is, you are monitoring the playback sound on the track, not the sound being recorded to the track.

* The following example shows that all tracks are in Playback Monitoring mode.

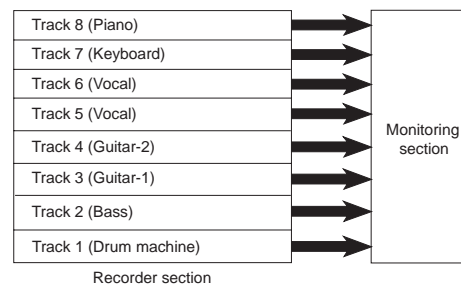

In this example, all tracks 1-8 are playing the recorded sound in Playback Monitoring mode.

* To play the sound on an Additional track, you need to move the data from the Additional track to a Real track. Refer to “Track Exchange function” on page “72” for more information.

Audio file and event

<About an audio file>

During recording, the recorder consecutively records an independent audio file (recorded area) in each track of each Program. However, you can record data on the recorder at any point within 24 hours of ABS time, and you can intentionally create silence between two audio files. In this case, a silent part is counted as a 0 file.

Therefore, audio files and 0 files are consecutively created as shown in the diagram below.

The total number of these audio files and 0 files is called “the number of events.” The maximum number of events is 512 per track (tracks 1-24). After the number of events reaches 507, new data will not be recorded.

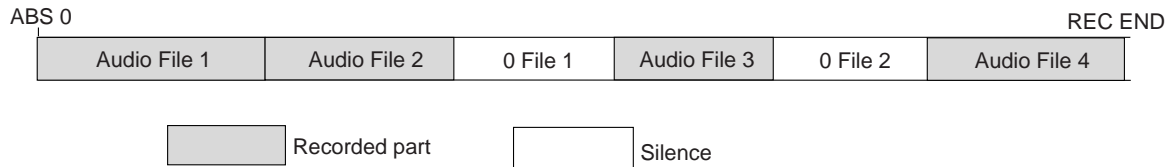

Usually, an event is created by one recording or edit. The number of events increases or decreases depending on the number of edit points or the amount of disk free space. (The recorder disk management operates in such way that the number of events will decrease.) The number of events does not affect usual music production. However, if a small amount of single-track data is written in many different sections on the disk, the maximum number of events may be reached. To avoid this “event number overflow,” you need to check the number of events for each track.

The recorder provides an event check menu in Setup mode for this purpose.

<Notes on digital recording>
 During analog recording, “0 files” are not created since silence does not create “data 0.” However, during S/P DIF and adat digital recording, the recorder records “data 0” (this is called “mute recording”). When one second of consecutive data 0 is input to the recorder, it creates a “0 file” and limits the consumption of disk space. However, repeating this operation will eventually increase the number of events, leading to “event number overflow.”

What is an event?

As shown in the diagram below, the number of events can be eleven or more if partial recordings are made. This is because an unrecorded part is regarded as an event, and a recorded part is also regarded as an event(s). The duration of each event can vary from 740 msec to 23 hours 59 minutes 59 seconds (FS =44.1kHz).

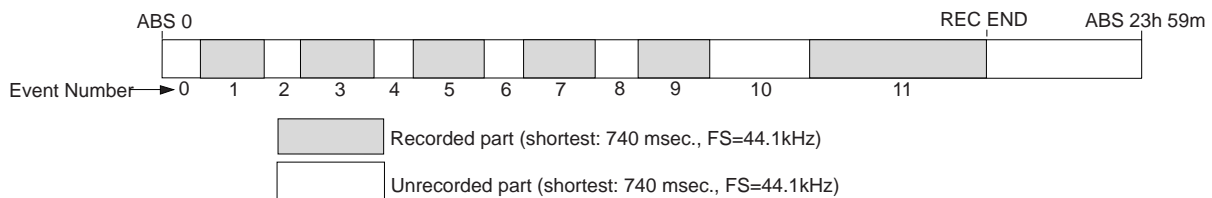

An unrecorded part (zero file) is always regarded as one even, regardless of its duration.

However, a recorded part can consist of a group of multiple audio file, as shown in the diagram below. More precisely, one audio file will be divided into multiple audio files if perform many editing operations (such as , copy & paste, move & paste, etc.) on this audio file. Multiple audio files created in this way are regarded as events. (If you do not edit the data at all, the audio file remains in one piece and is regarded as one event.)

In this example, one recorded area consists of six consecutive audio files. This means that this part consists of six events.

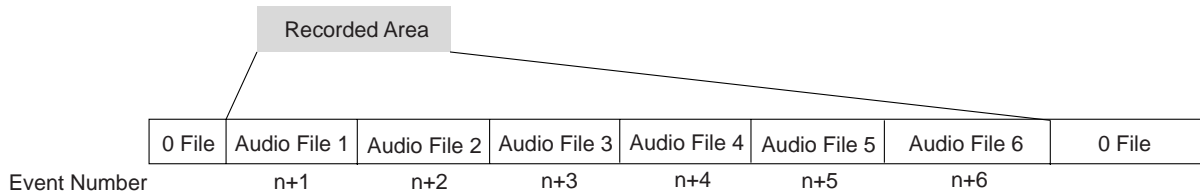

This is because when you perform a copy & paste, move & paste, or Auto Punch In/Out, the event is split at the edit point. Also, if a continuous long recording is made, the recorded data might scatter to different locations on the hard disk, thus dividing the data unto multiple events.

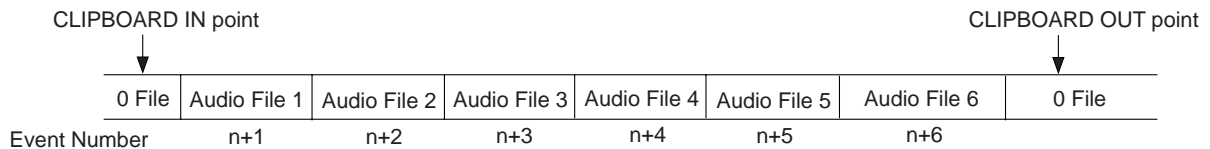

Countermeasures against accumulating too many events due to a long recording plus many editing operations:

One solution is to save and re-load the data to and from a DAT, adat, or SCSI device. (If the song is too long, you may not be able to save the data to a DAT or adat.)

In this way, multiple consecutive audio files are optimized into one continuous audio file in some cases. Set the Clipboard In point and the Clipboard Out points within an unrecorded range to copy the area (the area that contains multiple audio files and you wish to optimize) between them, then paste the data starting from the same Clipboard In point. Multiple audio files within this range will become a single audio file.

<Hints>

Make sure that you set the Clipboard In/Out points within zero files, and that you paste the area starting from the same Clipboard In point.

** In any case, bear in mind that you cannot reduce the excessive number of events if the target range contains a zero file.*

Formatting and Optimizing Disks

This section describes how to format and optimize a current drive disk and a backup disk. You can also find information regarding formatting and optimizing the disks in the Quick Operation Guide and in the “Saving and Loading Song Data” section of this manual.

Formatting a current drive disk

Before you format a current drive disk, specify the sampling frequency and bit (data) resolution, Multiple Undo on/off, and format type parameters. Refer to the table below for more information on these settings.

<Detailed formatting parameters>

Sampling Frequency		44.1kHz		48kHz		96kHz
Quantization		16 bits	24 bits	16 bits	24 bits	24 bits
Multiple Undo Function	On	Turn this function on to use the Multiple Undo function for all takes (recordings and edits). This function consumes more disk space. If you are using a small capacity disk, turn this function off.				
	Off	Turn this function off to use the undo/redo function only for the current take (recording or edit). If the capacity of the current drive disk is small, turn this function off.				
Format Type	Standard Format (Default Setting)	The recorder formats a disk while evaluating the integrity of the disk, including the access time for each block on the disk. Time required for formatting is longer, but you can be sure of a highly reliable format. Ordinarily, this format type is selected. This option is displayed and accessible whether you format a new disk or reformat an old disk.				
	Quick Format	With this simple format type, the recorder assumes that all sectors on the hard disk are of good quality. Time required for formatting is shorter, but any bad sectors would not be detected. Select this format type when you format a brand new disk for which Fostex has confirmed quality operation. You can select this format type only when you format a new disk or reformat a disk previously formatted with Quick Format.				
	Erase Format	You can select this format type only when you reformat a disk previously formatted with Standard Format. Use of this format will erase all data on the disk while keeping the Standard Format. Time required for formatting is shorter than when using Standard Format.				
Track architecture	D824	8 real tracks + 16 additional tracks				
	D1624	16 real tracks + 8 additional tracks				8 real tracks + 16 additional tracks
Recording	D824	<ul style="list-style-type: none"> * 8-track simultaneous analog recording * 8-track simultaneous analog (6 tracks) and digital (2 tracks - S/P DIF) recording * 8-track simultaneous adat digital recording 				
	D1624	<ul style="list-style-type: none"> * 8-track simultaneous analog recording * 8-track simultaneous analog (6 tracks) and digital (2 tracks - S/P DIF) recording * 16-track simultaneous analog (8 tracks) and digital (8 tracks - adat) recording * 16-track simultaneous adat digital recording <p><Note>: A current drive formatted with 96kHz/24-bit offers the same recording capacity as that of the D824.</p>				
Save/Load	D824	<ul style="list-style-type: none"> * Saving and loading data via a DAT or adat * Saving and loading data via SCSI 				
	D1624	<Note>: A current drive formatted with 96kHz/24-bit does not support the saving and loading operation via a DAT or adat.				

<Available recording time after formatting (common to D824 and D1624)>

A greater sampling frequency will reduce the available recording time/space after formatting. Under the same sampling frequency setting, the greater quantization (bit number) reduces the available recording time. The following table shows the "approximate available recording time" under each sampling frequency/quantization. Depending on your medium, the available recording time may differ slightly. It will be a good idea to check the available recording time after formatting.

Capacity	44.1kHz		48kHz		96kHz
	16 bits	24 bits	16 bits	24 bits	24 bits
10.0GB	Approx. 1888 min.	Approx. 1258 min.	Approx. 1735 min.	Approx. 1156 min.	Approx. 577 min.

Formatting a brand new hard disk

This section describes how to format an E-IDE hard disk used for the current drive, assuming that a hard disk has already been installed in the recorder.

1. Turn on the power to the recorder.

The recorder displays the ROM version, time and date, then displays [Initializing...], [Current IDE Drv], [(model name of the hard disk)] in this order, then [Unformat !] momentarily. Finally, the unit displays the Disk Format menu in Setup mode, showing the following screen.

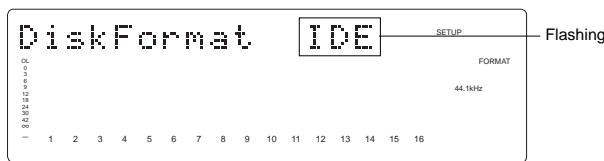

2. Press the EXECUTE/YES key.

The model name of the current drive's hard disk appears and [SURE ?] flashes, asking if you wish to format the hard disk. (The "***" mark represents the model name.)

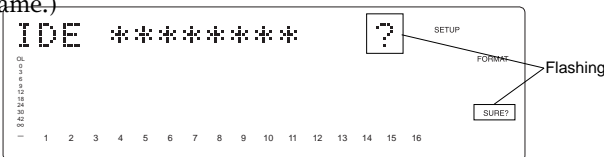

3. Press the EXECUTE/YES key.

The recorder displays the screen that enables you to set the sampling frequency and bit resolution. (With the default setting, [44.1kHz 24bit?] appears.) Refer to the table on page 30 and turn the JOG dial to select the desired setting from among [44.1kHz 24bit?], [44.1kHz 16bit?], [48kHz 24bit?], [48kHz 16bit?], and [96k 24bit 8trk?].

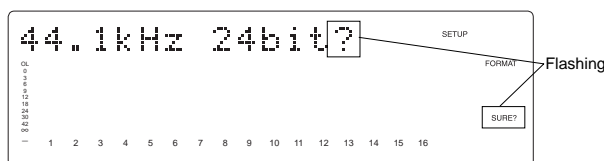

4. After you select the desired sampling frequency and bit resolution using the JOG dial, press the EXECUTE/YES key.

The recorder displays the screen which enables you to set the Multiple Undo function on or off.



5. After setting the Multiple Undo function on or off using the JOG dial, press the EXECUTE/YES key.

The recorder displays the screen which enables you to select the format type. With the default setting, [Standard Format?] appears. If you are formatting an unformatted disk, you can select either Standard Format or Quick Format.

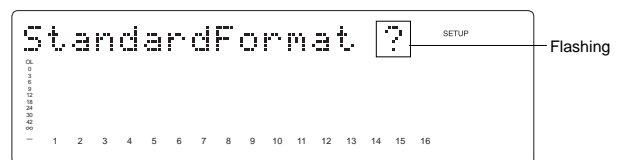

6. Use the JOG dial to select the desired format type, then press and hold down the RECORD button and press the EXECUTE/YES key.

The recorder starts formatting the disk, and displays the size of the unformatted area on the target disk. This value counts down as the formatting operation proceeds. Also, all the LED segments at the "∞" level of the meter light up, and each one of them turns off sequentially from right to left as the formatting operation proceeds. Wait until the format operation is complete. Formatting a hard disk of large capacity using the Standard Format type will take more time. (Quick Format will be completed immediately.)

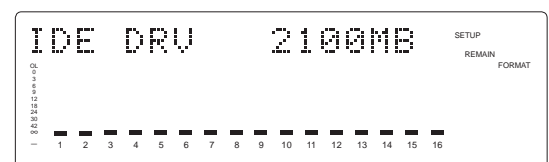

7. After formatting is complete, press the EXIT/NO key (or the STOP button).

The recorder exits Setup mode and indicates the top of the disk in the ABS time base. Formatting creates a new Program on the disk.

Reformatting an E-IDE hard disk

This section describes how to reformat a formatted E-IDE hard disk. Reformatting a disk will erase all Program data on the disk and the number of Programs and parameter settings will return to their default status. To reformat a disk, put the recorder into Setup mode to display the [Disk Format?] menu.

1. Turn on the power to the recorder.

The recorder indicates the start point of the Program (shown as ABS 0) last used before you turned off the power to the unit.

2. Press the SETUP key to put the recorder into Setup mode.

The recorder displays the [Signature Set ?] menu.

3. Use the JOG dial to select [Disk Format ?] and press the EXECUTE/YES key.

[IDE] flashes on the screen.

4. Press the EXECUTE/YES key while [IDE] is flashing.

The model name of the current drive's hard disk appears and [SURE ?] flashes.

5. Press the EXECUTE/YES key.

The recorder displays the screen that enables you to set the sampling frequency and bit resolution.

6. Select the desired sampling frequency and bit resolution using the JOG dial, and press the EXECUTE/YES key.

The recorder displays the screen which enables you to set the Multiple Undo function on or off.

7. Set the Multiple Undo function on or off using the JOG dial, and press the EXECUTE/YES key.

The recorder displays the screen which enables you to select the format type. If you have formatted the disk with Standard Format, you can select either Standard Format or Erase Format.

If you have formatted the disk with Quick Format, you can select either Standard Format or Quick Format.

8. Use the JOG dial to select the desired format type, then press and hold down the RECORD button and press the EXECUTE/YES key.

The recorder starts formatting the disk.

Formatting a backup disk (SCSI disk)

This section describes how to format a SCSI backup disk connected to the SCSI connector on the recorder. You can use any SCSI backup device that is set to ID=6. All backup disks will be formatted with the 48kHz/24-bit setting. The explanation below assumes that you have connected an external SCSI device with an ID number of "6" to the recorder, and a disk (unformatted or formatted) has already been inserted to the device.

<Note>
 You cannot use the [Disk Format ?] menu of the recorder to format a disk to be used for saving and loading .wav files. Format such a disk on your computer (PC/AT machine).

1. Press the SETUP key to put the recorder into Setup mode.

2. Turn the JOG dial to select the [Disk Format?] menu and press the EXECUTE/YES key.

[IDE] flashes. Turning the JOG dial will toggle between flashing [IDE] and flashing [SCSI 6].

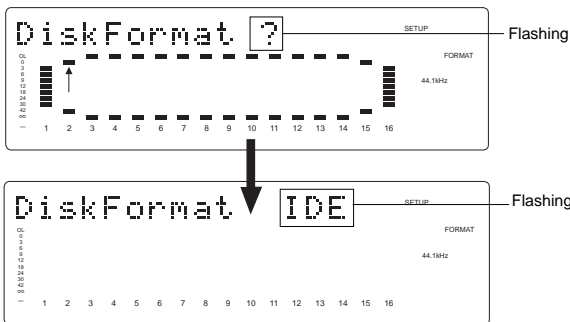

3. Use the JOG dial to select flashing [SCSI 6] and press the EXECUTE/YES key.

The ID number and the drive name appear, and [?] and [SURE ?] flash, regardless of whether the disk in the SCSI drive is unformatted or formatted.

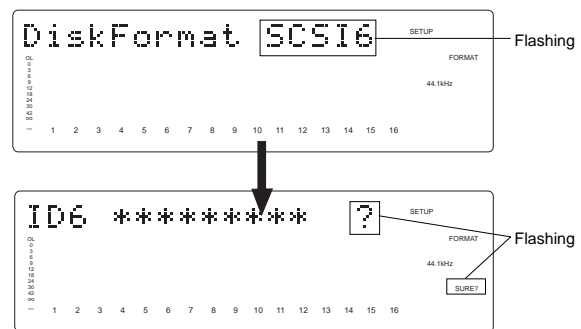

4. Press the EXECUTE/YES key again.

[24bit Backup ?] appears and [?] and [SURE?] flash. This means that the recorder is ready for formatting the backup disk with a 24-bit backup format.



5. Press and hold down the RECORD button and press the EXECUTE/YES key.

The recorder starts the backup format operation. During the format operation, [REMAIN] lights up on the screen and the recorder indicates the size of the unformatted area on the disk, which counts down as the format operation proceeds. Wait until formatting is complete. When the format operation is complete, [COMPLETED !] lights up and the disk stops spinning.

6. Press the EXIT/NO key (or the STOP button) to exit Setup mode.

The recorder displays the time base value of the current drive that was shown before the unit entered Setup mode.

To eject the disk from the backup drive, press the EJECT button on the drive.

Optimizing the disk

If you are using a disk that was formatted with the Multiple Undo function turned on, free disk space becomes smaller quickly because the disk always keeps the Multiple Undo files. Optimizing such a disk (using the [Disk Optimize?] menu in Setup mode) will increase free block space.

<Note>
 After you record multiple takes, if you optimize the disk (with the Multiple Undo function turned on), you will be able to undo only the most recent take. Therefore, if you wish to keep some takes, perform the Multiple Undo function or use the Program duplicate function to restore the take, then optimize the disk. For more information, see "Multiple Undo Function" on page 64.

1. While the disk is not being accessed, press the SETUP key to put the unit into Setup mode.

4. Press the EXIT/NO key (or STOP button) to exit Setup mode.

2. Turn the JOG dial to select the [Disk Optimize?] menu and press the EXECUTE/YES key.

The recorder displays the following indication and [SURE ?] flashes.

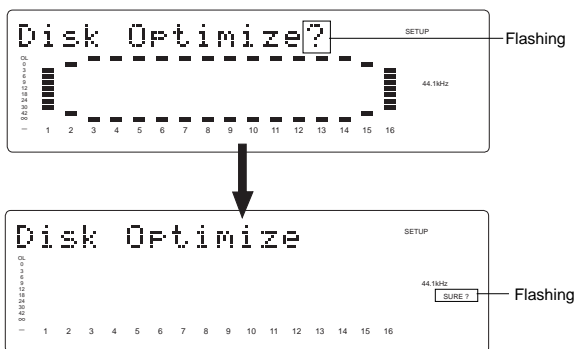

3. Press and hold down the RECORD button and press the EXECUTE/YES key.

The disk optimize function starts. When it is complete, [COMPLETED!] lights up.

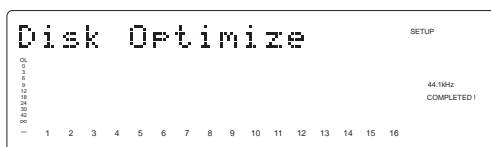

Handling Programs

This chapter explains how to handle Programs. It covers the following topics:

1. Creating a new Program
2. Using a Program Change function
3. Duplicating a Program
4. Deleting a Program
4. Editing a Program title

Creating a new Program

You can manage individual songs by setting multiple programs on the disk, as explained in the “Managing Songs by Program Selection” section of the “Before Starting” chapter. You can set up to 99 Programs. One Program is automatically created on the disk when the disk is newly formatted with this equipment.

Follow the steps below to create a new Program. The prerequisite of this operation is that the disk is in an “initial state” where there is only one Program on the disk.

<Note>

When a new program is made, the same initial setup of the currently active program will be copied as the initial setting for the new program. If you wish to make a new program under the same settings as those of a previous program, call up the desired program to be copied before making the new program.

1. Turn on the power to the recorder.

Upon starting up the recorder, [Initialize...]->[Current IDE Drv] ->[Hard disk model number]->[Storage mode ([Standard format] in this case)] messages are followed with an ABS time base, then show the top of the Program (ABS 0). At this time, the current Program is indicated as [P01].

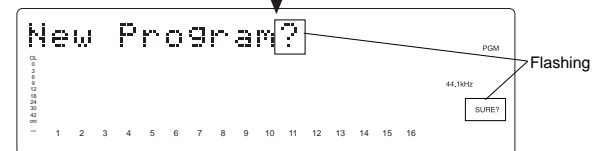
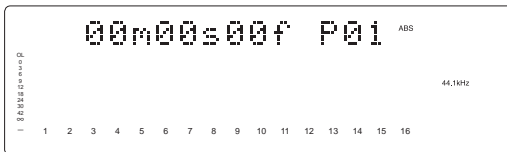

2. Press the PGM key.

[Select PGM!] appears on the display briefly, then changes to a flashing [01] of [P01] and [SURE?] flash. ([#0001] is the default name of PGM 01.)

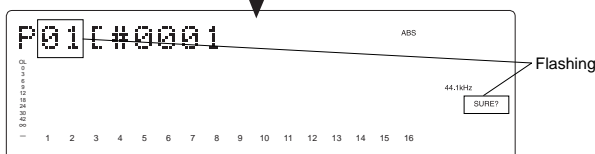

3. Turn the JOG dial clockwise.

The question marks [?] of [New Program?] and [SURE?] flash. This indication asks you if you wish to set a new Program (Program 2).

4. Press the EXECUTE/YES key.

The recorder automatically enters [Title Edit PGM?] menu in SETUP mode. You can enter a title for Program 2. ([?] flash.) If you prefer the default name, press the EXIT/NO key.

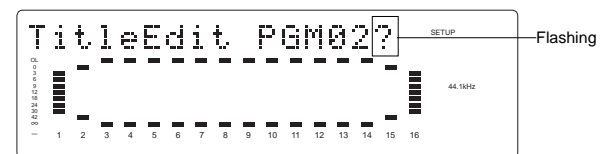

5. Press the EXECUTE/YES key again.

A default title (#0002) appears on the display, with [#] and [SURE?] flashing. This means that you can enter a name for the new Program.

If you wish to name the Program with a unique title, continue the steps below.

In either case, you can change the title later, as explained in “Editing a Program title.”

To enter a title:

- Turn the JOG dial, or pressing the NEXT key and PREV key for the flashing cursor to voluntarily input alphanumerics.
- Move the flashing cursor with the SHUTTLE dial. The title can contain up to 16 alphanumeric characters.
- You can input the following alphanumerics and symbols.

```

# $ % & ' ( ) * + , - . / 0 1 2 3 4
5 6 7 8 9 : ; < = > ? @ A B C D E F
G H I J K L M N O P Q R S T U V W X
Y Z [ \ ] ^ _ ` a b c d e f g h i j
k l m n o p q r s t u v w x y z ( |
) ~ € _ ! "

```

6. When you finish entering the title, press the EXECUTE/YES key.

Program 2 (PGM 02) and its title are set.
The display shows the ABS Time Base indication of the Program.

**7. Press the EXIT/NO key, or STOP button.****<Important!>**

- When you create a new Program by selecting the [New PGM ?] menu, a new Program is created with an increment number.

That is, if only one Program exists and when you create a new Program, it will be named Program 2.
If Programs 1-5 already exist, a new Program number will be 6.

- If there is insufficient recording space on the disk, you cannot create the new Program. Each time you create a new Program, the recordable area on the disk will decrease.

Duplicating a Program

Any program content (Recording data/various setup items) can be duplicated but with a separate program number.

<Notes>

- * Duplicating a program is possible only when the Multiple Undo function is set to ON when formatting the current drive. In a current drive with this setting at OFF, the [PGM Duplicate?] message will not display when pressing the EDIT key mentioned below.
- * The program which can be duplicated must be the currently active program. Therefore, the program you wish to duplicate must be activated prior to executing the duplicating mode.

1. With this recorder in the stop mode, press the EDIT key to display [PGM Duplicate?] (? flashes).

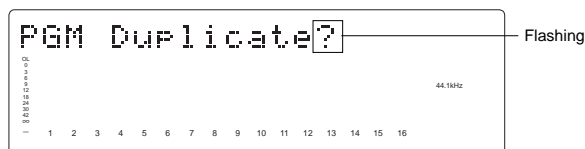

2. Press the EXECUTE/YES key.

As an example, the following is displayed and [SURE?] will flash. This means that program 01 will be duplicated for program 05, the new program 05. Refer see <Note> below.

**<Note>**

The program to be duplicated will be assigned with a program number following that of the program presently existing in the disk.

If [Duplicate P01 > 05] is displayed as in the previous example, this indicates that four programs presently exist in the disk and that the new program will be number 05.

If the duplicated program is to be checked or you wish to switch to this program, refer to the next item "Selecting a program."

3. Press the EXECUTE/YES key again.

The display will change to head of the duplicated original program (P01 in this example), and [COMPLETED!] will light.

4. Press the EXIT/NO key (or STOP button).

[COMPLETED!] will be extinguished.

By following these procedures, the same content in program 01 is duplicated in program 05.

Using a Program Change function

If multiple Programs exist on the disk, you need to select a Program to record, play, or edit. This section describes how to select a Program.

<Note>

You cannot use the Program Change function when the recorder is in SETUP mode.

1. When the recorder is stopped, press the PGM key.

[Select PGM] appears on the display briefly, then changes to a flashing "01" ([#0001 of PGM 01] and [SURE?] flash. ([#0001] is the default name of PGM 01.)

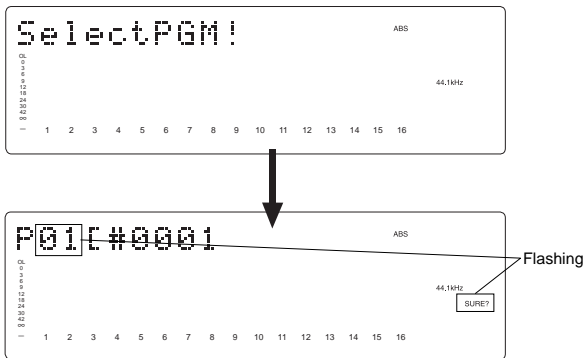

2. Turn the JOG dial to select the desired Program number (flashing).

Rotating the JOG dial counter-clockwise decreases the number, and rotating it clockwise increases the number. If you turn the JOG dial clockwise all the way, [New Program?] will be selected. Select [New Program ?] to create a new Program as mentioned in the previous section "Creating a new Program."

For example, you can select one of seven Programs as follows:

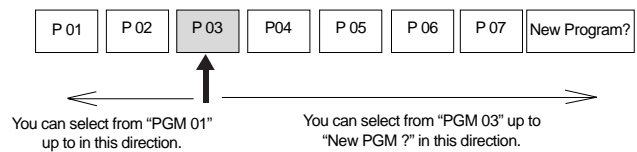

3. Press the EXECUTE/YES key.

The ABS Time Base indication for the selected Program appears.

In this way, you can be sure to select a Program before you start working.

Deleting a Program

This section explains how to delete an unnecessary Program. Deleting an unnecessary Program will expand the recordable area, making your work flow more smoothly, since recording or editing requires sufficient recordable area (free space on the disk). Use the [Delete PGM ?] menu in SETUP mode to delete a Program.

<Notes on deleting a Program>

- You can delete only the currently-selected Program. Refer to the previous section, "Using a Program Change function," for information on how to select the desired Program before you proceed to delete the Program.
 - If only one Program exists and you try to delete it, data contained in the Program will be deleted, but the Program itself will remain. For example, assume that PGM 01 -07 exist and you try to delete PGM 05. Program number 05 will remain, but the data inside PGM 05 will be replaced with the data of PGM 06. The subsequent Programs' data will move in the same way. Therefore, it will appear that PGM 07 has been deleted. If you delete the last Program (PGM 07 in this example), PGM 07 will be completely deleted.
- If you try to deleted PGM 05, only the data of PGM 05 will be deleted and the data of PGM 06 will move into PGM 05.

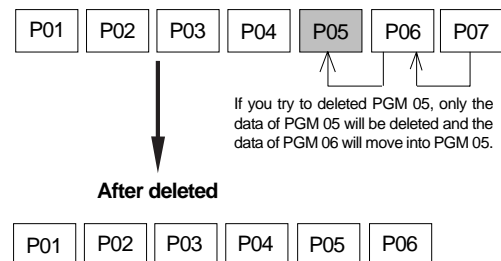

<Note>

You cannot use the Single Undo/Redo function, and Multiple Undo function to delete Programs. Make sure that you delete the correct Program.

1. Press the SETUP key while the recorder is stopped, to put the system in the SETUP mode.

The recorder enters SETUP mode, and displays the first hierarchy of the SETUP menu that was displayed before you turned off the power. The default setting is [Signature Set ?] menu.

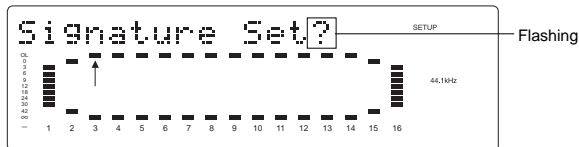

2. Turn the JOG dial to select the first hierarchy of the [Delete PGM ** ?] (deleting a Program) menu.

Alternatively, you can use the SHUTTLE dial.

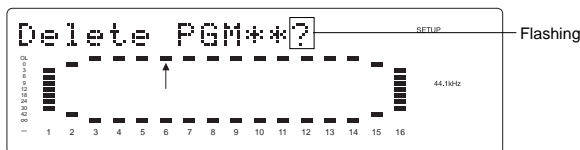

3. Press the EXECUTE/YES key.

The display will change and [SURE?] will flash? This indicates that the system is in the stand-by state to delete a program that is currently started up.



To cancel the delete operation, press the EXIT/NO key while [SURE ?] is flashing. Each time you press the button or key, the recorder will return to a higher level in the hierarchy, and finally exit SETUP mode.

4. Press the EXECUTE/YES key again.

When the recorder displays [Deleting...] and finishes deleting the Program, the data of the next Program number moves in, and its ABS time appears.

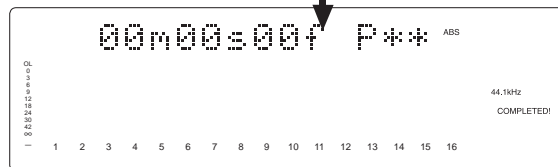
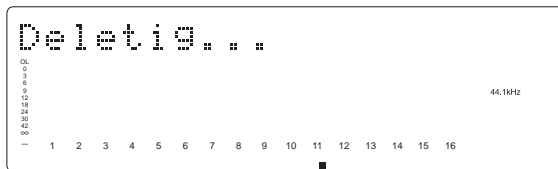

5. Press the EXIT/NO key, or STOP button.

To check the REMAIN time and free space, press the DISP SEL key to display the [REMAIN] indication after the Program is deleted.

Editing a Program title

You can name the Program as explained in the “Creating a new Program” section. You can also change the title later by using the [Title Edit ?] menu in SETUP mode.

<Note>
 You can edit the title of the selected Program before you select SETUP mode. You cannot select a Program after the recorder enters SETUP mode. Be sure to select the desired Program using the steps explained in the “Using the Program Change function” section.

1. Press the SETUP key while the recorder is stopped, to put the system in the SETUP mode.

The recorder enters SETUP mode, and displays the first hierarchy of the SETUP menu that was displayed before you turned off the power. The default setting is [Signature Set ?] menu.

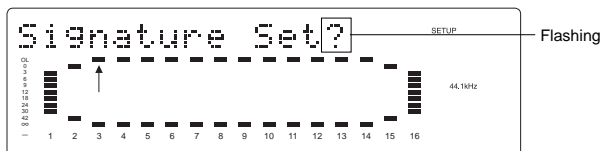

2. Turn the JOG dial to select the first hierarchy level of the [Title Edit ?] ([?] flash.) menu.

The JOG dial to select the indication. The following example assumes that the title of Program that can be edited is Program 2.

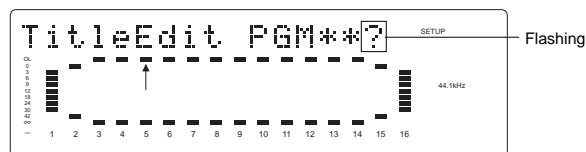

3. Press the EXECUTE/YES key.

The currently-selected Program title appears with the left-most character flashing.

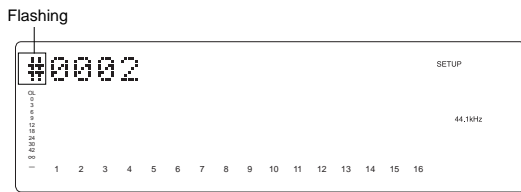

4. Move the flashing cursor with the SHUTTLE dial and input the letter or number with the JOG dial / NEXT key / PREV key.

Up to 16 digits and the following letters / numbers / symbols can be input.

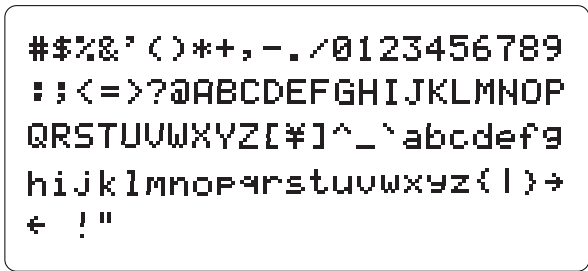

5. After you enter the title, press the EXECUTE/YES key.

The new title is confirmed, and the ABS time value of the Program appears.

6. Press the EXIT/NO key, or the STOP button.

<Check the title input>
 To check the title that was newly input, press the DISP SEL key and then switch to the SETUP mode. The newly input title will appear when the SETUP mode appears. After confirming the title, press the DISP SEL key to switch back to the top of the previous Program indication.

Punch In/Out

What is Punch In/Out recording?

Punch In/Out recording enables you to record over previously-recorded parts. See the diagram below. For example, using the Punch In/Out function allows you to change an unsatisfactory guitar solo. The D824/D1624 offers two types of Punch In/Out functions. One is called Auto Punch In/Out, in which you automatically re-record a specified part. The other is called Manual Punch In/Out, in which you record data manually (using your foot to operate an optional foot switch, model 8051). Both functions feature “Rehearsal mode” to enable you to practice repeatedly until you are ready.

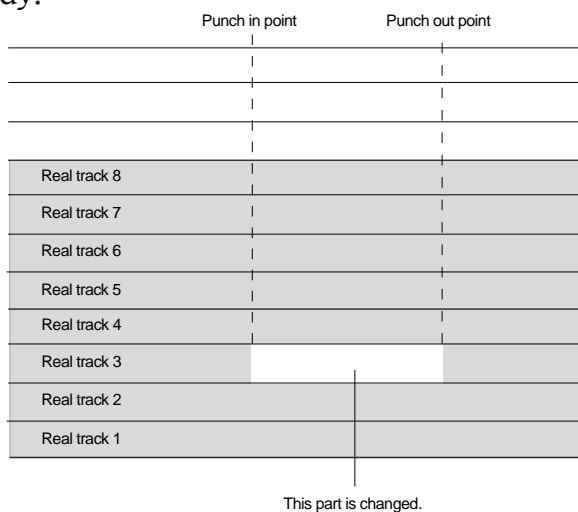

- Select a Program for Punch In/Out recording.
- Initialize the recorder.

<Note>

You can use the Punch In/Out recording only for Real tracks. If you wish to use Punch In/Out recording for data on an Additional track, first move the data to the Real tracks.

Auto Punch In/Out

To perform Auto Punch In/Out recording, you need to specify the Auto Punch In point (recording start point) and the Auto Punch Out point (recording end point).

Preparation

Storing the edit points

1. Refer to “Storing the edit points” to set the Auto Punch In/Out points.

Store the Auto Punch In point to the AUTO PUNCH IN key, and the Auto Punch Out point to the AUTO PUNCH OUT key.

- Refer to page “54” for more information on storing the edit points.

<Note>

Make sure that you specify an Auto Punch In point that precedes the Auto Punch Out point. If the Auto Punch Out point precedes the Auto Punch In point, [Void Out !] appears and you will be unable to perform Auto Punch In/Out recording.

Previewing and trimming the edit points

You can check the stored edit points by pressing the corresponding memory keys to display them on the LCD. You can also change the points if necessary. In this example, use the Preview function to fine-tune the point while previewing.

1. While the recorder is stopped, hold down the SHIFT key and press the memory key.

Pressing the AUTO PUNCH IN key enables you to listen to the sound at the AUTO PUNCH IN point (“previewing the sound rise [fade-out]”). Pressing the AUTO PUNCH OUT key enables you to listen to the sound at the AUTO PUNCH OUT point (“previewing the sound fall [fade-in]”).

2. Trim the edit point while auditioning the sound.

- Refer to page “63” for more information on the Preview function.

When you finish storing and adjusting the respective edit points, you can proceed to the Auto Punch In/Out operations.

Explanations from here on will be on the assumption that an external mixer (analog or digital) and the recorder are interconnected as shown below and that a guitar for recording on track 3 is connected to the mixer input. A D1624 is used in the connecting example below.

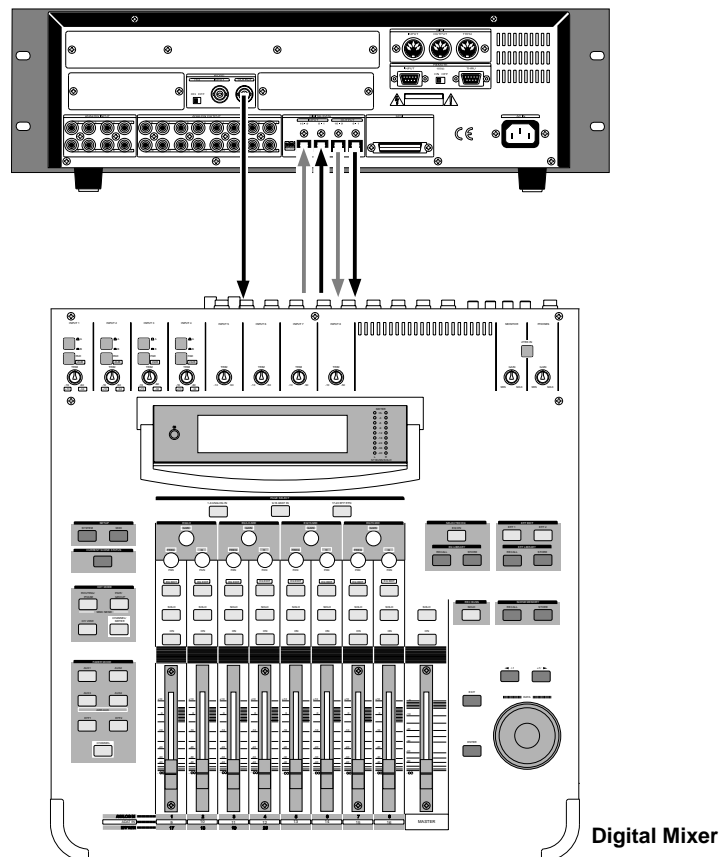
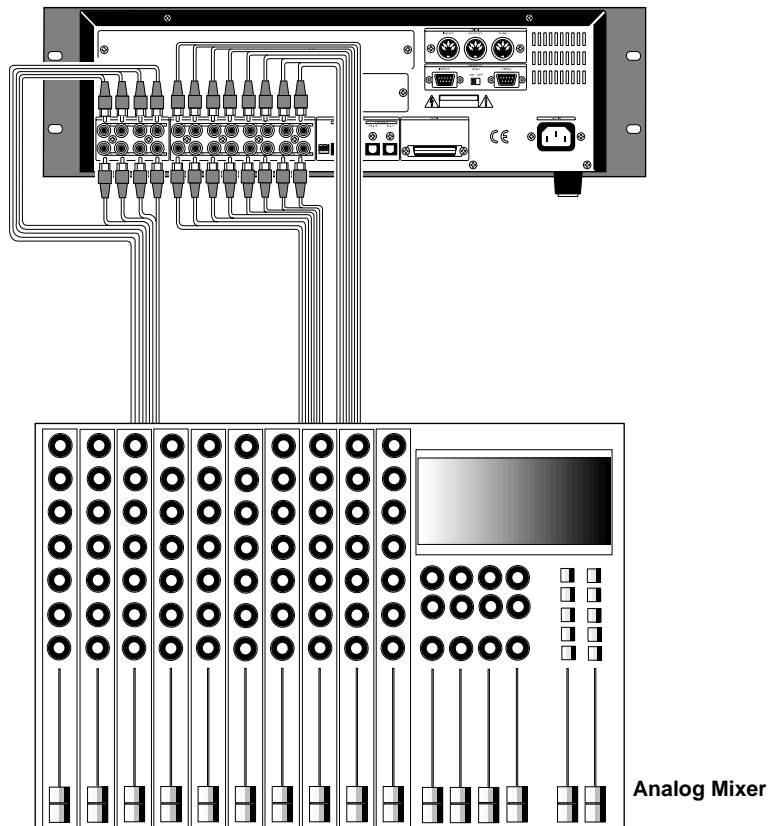

Rehearsing Auto Punch In/Out recording

In Rehearsal mode, the READY track assumes input monitoring mode between the Auto Punch In and Out points, and the sound is not recorded. You can practice Auto Punch In/Out operation repeatedly before you proceed to actual recording. Locate the recording start position slightly before the Auto Punch In point.

<Tips for rehearsal>

Set the preroll value while referring to the "Changing the Initial Settings (SETUP Mode)" chapter. In this way, the recorder can locate a point that precedes the Auto Punch In point by the specified preroll value. This enables you to start playback slightly before the Punch In point. (Refer to page "101" for more information on "Changing the Initial Settings.") The recorder will repeat playback data between the AUTO RTN START point and the AUTO RTN END point if you set the AUTO RTN START point before the Auto Punch In point and the AUTO RTN END point after the Auto Punch Out point. This allows you to repeat rehearsal. See the "Hint-2."

1. Press the AUTO PUNCH key.

The AUTO PUNCH mode will turn ON. The REHEARSAL LED (green) and TAKE LED (red) of the AUTO PUNCH key will flash.

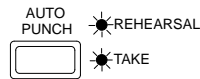

2. Set the track for Auto Punch In/Out to READY.

Press the RECORD RACK select key [3/11] to set track 3 to READY.

3. Start playback of the recorder from a point slightly before the Auto Punch In point.

Only the REHEARSAL LED (green) will light up, and start rehearsal. The recorder operates as shown in the figure below during rehearsal operations.

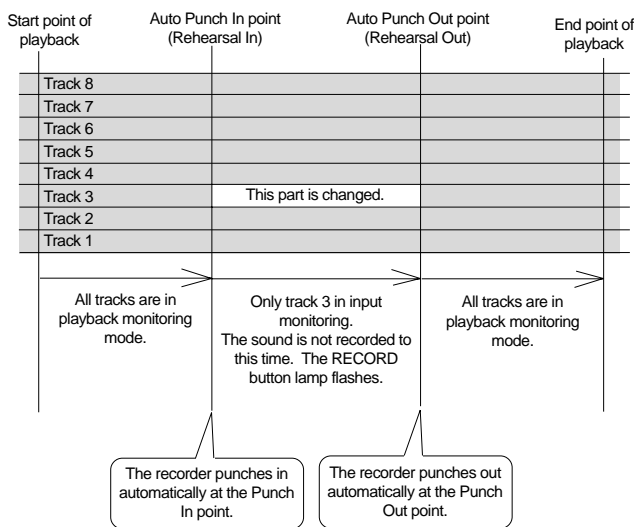
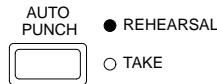

4. Play the guitar accompanying the playback sound from tracks 1 - 8 for rehearsal, while adjusting the recording level.

You will hear the guitar performance between the Auto Punch In and Out points. Otherwise, you will hear the recorded guitar sound.

5. When you are satisfied with your rehearsal, press the STOP button.

<Hint 1>

Locating a point slightly before the Auto Punch In point

To locate the playback start point for rehearsal, press the AUTO PUNCH IN key, then press the LOCATE key. The recorder displays the time (position) stored in the AUTO PUNCH IN key, and locates the point and stops. Press the REWIND button to go backward. If you have set the preroll time as described on page "108," you can locate a point that precedes the Auto Punch In point by the specified preroll value.

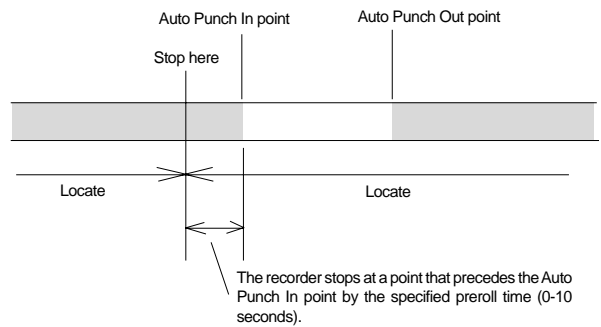

<Hint 2>

Quick and easy operation for repeated rehearsal

Using the Auto Return function and the Auto Play function enables you to rehearse repeatedly. As shown below, set the AUTO RTN START and END points for Auto Return and Auto Play. In this way, you can repeat rehearsal easily, while checking the recording level and concentrating on your performance. Refer to page "54" for more information on setting the AUTO RTN START/END points.

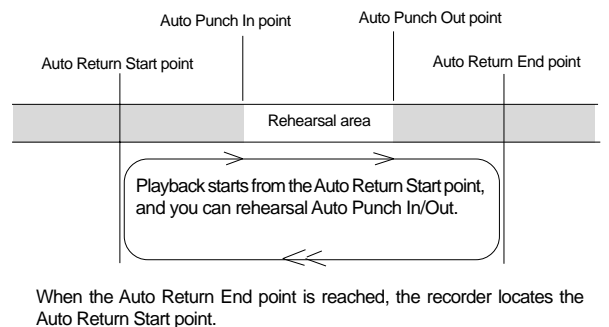

<Note>

If the recorder displays [Over!] when you turn on the Auto Punch mode, the disk does not have enough free space to perform Auto Punch In/Out. In such a case, erase any unnecessary sections, delete unnecessary program data or optimize the disk and execute again.

Auto Punch In/Out Take

After you are satisfied with your rehearsal, you can proceed to an actual take of Auto Punch In/Out. You can undo or redo Auto Punch In/Out recording if you change your mind. The control panel settings are the same as those for rehearsal.

1. Press the RECORD TRACK select key [3/11] to set track 3 to READY.

2. Locate a point slightly before the Auto Punch In point.

3. Confirm that Auto Punch mode is turned on.
Press the AUTO PUNCH key to turn on the function, if it is not already on (REHEARSAL/TAKE LED flashes).

4. Press the RECORD button while holding down the PLAY button.
Only TAKE LED (red) lights up and starts TAKE.

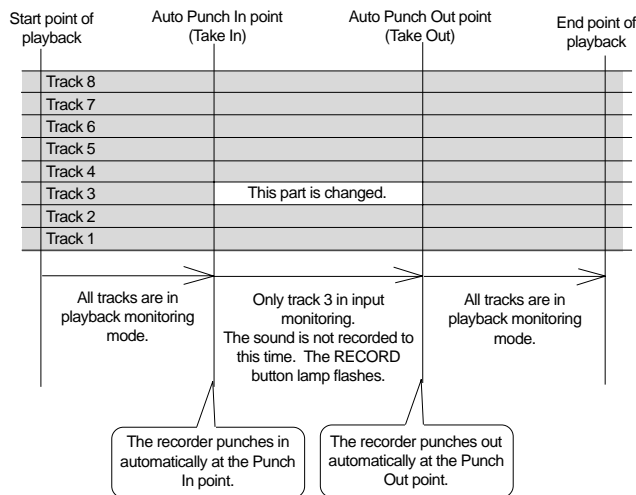
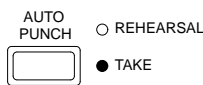

- Track 3 indication on the display will only light up between the AUTO PUNCH IN/OUT point, and will flash in any other case.
- When the Auto Punch Out point is passed, the recorder cancels Auto Punch mode automatically, and nothing appears in the A. PUNCH display area.

<Caution after Punch Out>

At "Take" of punch out, the punch-in recording track will not immediately enter the repro monitor mode from the input monitor mode enter the repro monitor mode about two seconds after mute playback. This is a functional feature of recorder and not a malfunction.

5. When you finish recording, press the STOP button.

6. Play track 3 to check the result of the Auto Punch In/Out operation.

If you fail with AUTO PUNCH IN/OUT and are not satisfied, repeat the process by performing the AUTO PUNCH IN/OUT undo operations described in the next section.

Single Undo/Redo Auto Punch In/Out recording

You can single undo or redo Auto Punch In/Out recording.

Press the UNDO/REDO key after recording is complete to restore the conditions that existed prior to the recording. Press the UNDO/REDO key again to restore the conditions that existed after the recording. However, the procedures explained here is for Single Undo/Redo and there are limitations as written in the Notes below. If the current drive was formatted with the multiple undo function ON, Multiple Undo is also possible. Refer to page "64" for details on the Multiple Undo function.

<Notes at executing sigle undo/redo>

Note-1: This function only works when this recorder is in the stop mode.

Note-2: After finishing auto punch in/out, please note that single Undo/Redo is not possible if the following have been executed.

- If a new recording has been made.
- When a new editing job is executed (such as Copy & Paste, Move & Paste, or Erase).
- When in the AUTO PUNCH ON mode, when the AUTO PUNCH IN point is passed in the PLAY (or RECORD) mode.
- If the power was switched off.
- If program select was executed.
- When multiple undo is executed.

Manual Punch In/Out

This section explains how to perform Manual Punch In/Out using a foot switch (optional Model 8051).

You do not need to specify the Punch In/Out points. Instead, you press the foot switch at the Punch In/Out point. Manual Punch In/Out also offers rehearsal and actual takes. You can repeat rehearsal until you are ready. As an example, replace a part of the recorded guitar solo on track 3.

- Initialize the recorder.
- Select a desired Program for Punch In/Out.
- Check a sampling frequency of the recorder and external device.

Preparation

Check to see that the guitar is connected to the input jack of the mixer, as required for [AUTO PUNCH IN/OUT] mentioned earlier.

Connect an optional foot switch (Model 8051) to the PUNCH IN/OUT jack on the rear panel.

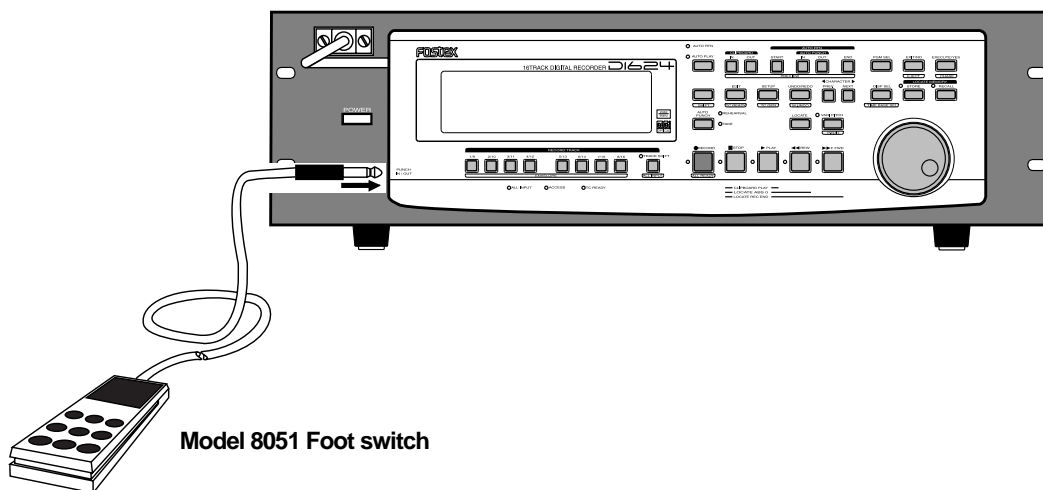

Rehearsing Manual Punch In/Out recording

In Rehearsal mode, the READY track enters input monitoring mode between the Punch In and Out points (the points at which you press the foot switch), and the sound is not recorded. You can practice the Punch In/Out operation repeatedly before you proceed to actual recording.

1. Press the foot switch while holding down the STOP button.

[Rehearsal On] will appear on the display or about 1 second, then rehearsal mode will appear and the REHEARSAL LED (green) of the AUTO PUNCH key flashes.

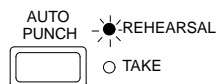

2. Press the RECORD TRACK select key [3/11] to set track 3 to READY.

3. Press the PLAY button to play back from a point slightly before the Punch In point.

4. Play the guitar accompanying the playback of tracks 1 to 8.

The recording level and monitor volume is adjusted on the mixer in the same manner as done for [AUTO PUNCH IN/OUT] described earlier.

5. Press the foot switch once at the desired Punch In point, then press the foot switch again at the desired Punch Out point.

The rehearsal mode will operate as shown in the figure. Between the Punch In and Out points the current performance of the guitar will be played as the guitar monitor sound. The previous recording is heard in any other case. The RECORD LED lights up when Punching In and turn off when Punching Out. (the REHEARSAL LED remains flashing)

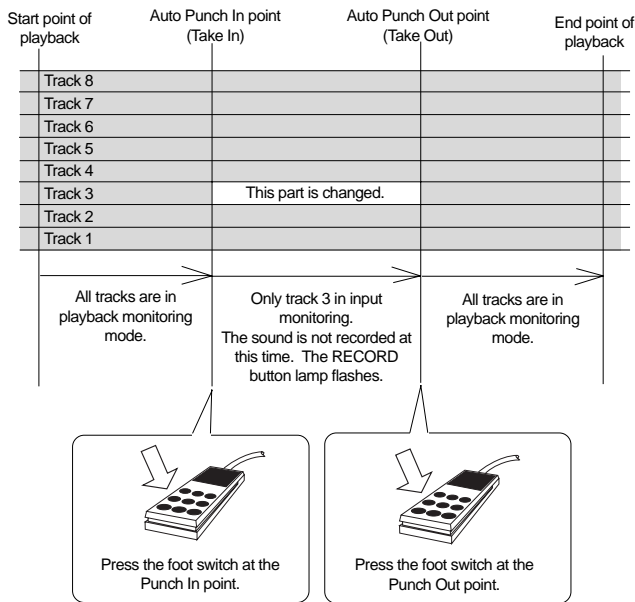

6. When you finish rehearsing, press the STOP button.

If you are still unsatisfied, repeat steps 3-5.

Cancelling Rehearsal mode

1. While holding down the STOP button, press the foot switch.

The display shows [Rehearsal Off] for 1 second, then the flashing REHEARSAL LED turns off and cancels the rehearsal mode.

<Hint>

To rehearse repeatedly, set the AUTO RTN START point slightly before the Punch In point, and the AUTO RTN END point slightly before the Punch Out point. This will help you concentrate on your performance or check the recording level easily (especially since Manual Punch In/Out involves operating the foot switch operation as well as the recorder). (See <Hint-2> in the "Rehearsing Auto Punch In/Out recording" for more information.)

Manual Punch In/Out take

You can proceed to record if you are satisfied with the recording level, foot switch timing, and rehearsal.

<Note>

You cannot record a second take during the Manual Punch In/Out operation without stopping the recorder. That is, the recorder will continue playing after you finish recording a take, but you cannot record another take by pressing the foot switch.

1. Confirm that Rehearsal mode is cancelled, and start playing the recorder from a point slightly before the desired Punch In point.
2. Play the guitar, accompanying the playback of tracks 1 to 8.
3. Press the foot switch at the desired Punch In point. Press the foot switch again at the desired Punch Out point.

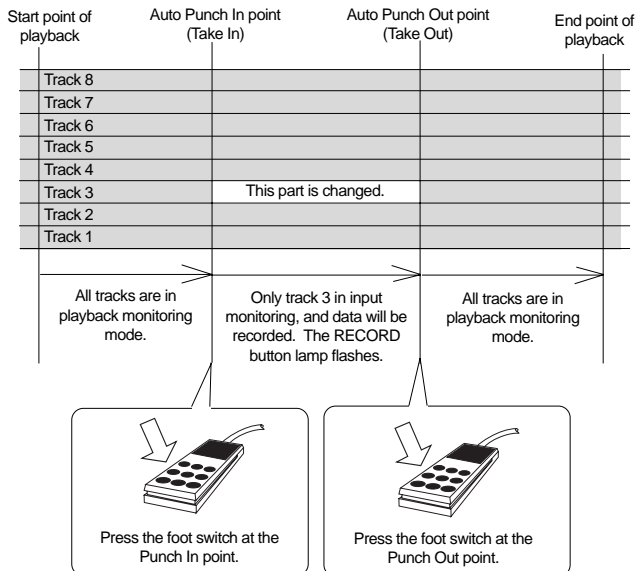

The recorder enters recording mode at the Punch In point, and cancels recording mode at the Punch Out point.

4. Press the STOP button.

5. Play track 3 and check the result of Punch In/Out.

<Caution after Punch Out>

At "Take" of punch out, the punch-in recording track will not immediately enter the repro monitor mode from the input monitor mode enter the repro monitor mode about two seconds after mute playback. This is a functional feature of the recorder and not a malfunction.

<Hint>

You can use the PLAY button and the RECORD button, instead of using the foot switch. Follow the steps below.

This method also does not allow you to record another take unless you stop the recorder first. Procedure:

1. Press the PLAY button to start playback from a point slightly before the Punch In point.
2. Press the RECORD button while holding down the PLAY button at the desired Punch In point. (Punch In recording starts.)
3. Press the PLAY button at the desired Punch Out point. (Recording is punched out.)

- If you press only the RECORD button in both steps 2 and 3, you can rehearse Punch In/Out.

Single Undo/Redo Manual Punch In/Out recording

You can single undo or redo Manual Punch In/Out recording.

Press the UNDO/REDO key after recording is complete to restore the conditions that existed prior to the recording. Press the UNDO/REDO key again to restore the conditions that existed after the recording. However, the procedures explained here is for Single Undo/Redo and there are limitations as written in the Notes below. If the current drive was formatted with the multiple undo function ON, Multiple Undo is also possible. Refer to page “64” for details on the Multiple Undo function.

<Notes at executing sigle undo/redo>

Note-1: *This function only works when this recorder is in the stop mode.*

Note-2: *After finishing manual punch in/out, please note that single Undo/Redo is not possible if the following have been executed.*

- *If a new recording has been made.*
- *When a new editing job is executed (such as Copy & Paste, Move & Paste, or Erase).*
- *When in the AUTO PUNCH ON mode, when the AUTO PUNCH IN point is passed in the PLAY (or RECORD) mode.*
- *If the power was switched off.*
- *If program select was executed.*
- *When multiple undo is executed.*

Recording Digital Data

Digital recording from an external digital device

This section describes how to connect an external digital device (CD, MD, and/or DAT player, and/or adat) to the recorder and record digital signals directly from the device. You can also connect a digital mixing console for multitrack recording (as explained in the separate Quick Operation Guide). To record digital data from an external digital device, set the tracks (assigned to the DIGITAL/DATA IN jack) to [SPDIF] or [adat] in the digital input setup menu in Setup mode. You must also select a clock (synchronous or asynchronous) for the digital input to determine whether the recorder will follow the external digital signal or the internal clock. The digital input setup menu is globally applied to all Programs.

Connecting an external digital device

1. Use an optical cable to connect the DIGITAL/DATA IN jack of the recorder to the OPTICAL OUT (or adat OUT) jack of the external digital device.

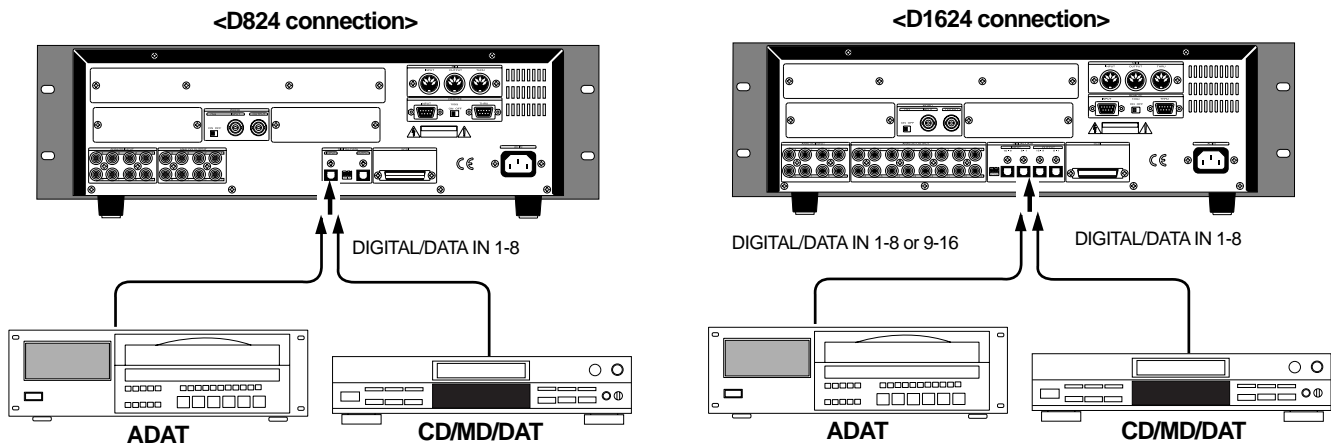

<Notes regarding the digital connection>

The DIGITAL/DATA IN jack of the D824/D1624 can be used either for an S/P DIF digital signal (optical) or for an adat digital signal. You must use the digital input setup menu in Setup mode to select one of them. These signals use the same jack but carry two different types of information.

<When using the D824>

Connect the DIGITAL/DATA IN 1-8 jacks to the OPTICAL OUT (or adat OUT) jack of the digital device. If you select [SPDIF Async] or [SPDIF Sync] for the digital input, Inputs 1-8 are assigned to tracks 1 and 2. If you select [adat Async] or [adat Sync] for the digital input, Inputs 1-8 are assigned to tracks 1-8 respectively.

<When using the D1624>

To input an S/P DIF digital signal to the D1624, use the DIGITAL/DATA IN 1-8 jacks. To input an adat digital signal, use the DIGITAL/DATA IN 1-8 or 9-16 jacks. If you select [SPDIF Async] or [SPDIF Sync] for the digital input, Inputs 1-8 are assigned to tracks 1 and 2. If you select [adat Async] or [adat Sync] for the digital input, Inputs 1-8 are assigned to tracks 1-8 and Inputs 9-16 are assigned to tracks 9-16 respectively.

Note that only the DIGITAL/DATA IN 1-8 jacks can be used on the D1624 when you save the song data. (For more information, see "Saving and Loading Song Data" on page 84.)

* If the connected external device has only a COAXIAL (RCA pin) jack for digital output, use an optional Fostex COP-1/96k (optical/coaxial converter).

Selecting a recording Program

1. If you already have multiple Programs, select the desired Program using the Program Select function.

* See page "36" for more information on the Program Select function.

Setting the digital input

Use the digital input setup menu in Setup mode to assign tracks and select a digital input clock.

With the default setting, the digital input is set to [Analog] (no assign), which means no digital signal can be input. To record digital signals from the connected external device, you must set the digital input to [SPDIF Async (asynchronous)] [SPDIF Sync (synchronous)], [adat Async (asynchronous)], or [adat Sync (synchronous)], depending on your purpose. Depending on your selection, tracks are assigned as follows:

* When SPDIF Async or Sync is selected:

<Both D824 and D1624>

Inputs 1-8 are assigned to tracks 1 and 2.

* When adat Async or Sync is selected:

<D824>

Inputs 1-8 are assigned to tracks 1-8.

<D1624>

Inputs 1-8 are assigned to tracks 1-8, and Inputs 9-16 are assigned to tracks 9-16.

To record data while synchronizing with a digital signal from the external digital device, select synchronous mode of [SPDIF] or [adat]. To record data while synchronizing with the internal clock of the recorder, select asynchronous mode of [SPDIF] or [adat] and set the [Clock Sel?] menu (operation clock setting) in Setup mode.

* See page "113" for more information on the [D. in?] menu.

Setting the operation clock of the recorder

If you have selected synchronous mode for the digital input tracks as described above, you must set the operation clock in Setup mode.

1. Use the [Clock Sel ?] (operation clock setting) menu to set the operation clock to [Int].

* See page "117" for more information on how to set the operation clock.

Also, refer to the table on the next page for more information on how to set the digital input tracks and operation clock.

<Notes>

* If the digital input has been set up, do not connect or disconnect an optical cable to or from the DIGITAL/DATA IN jack. Otherwise, the D824 (D1624) may generate noise, affecting the performance of the external digital device.

* If adat signals are input to the D1624, tracks not assigned to the digital input are automatically assigned to analog input. For example, if adat signal is connected to the DIGITAL/DATA IN 9-16 jacks and if you are not using Inputs 1-8 for adat input signal, you can assign tracks 1-8 for analog recording and tracks 9-16 for adat in to achieve 16-channel (analog + digital) simultaneous recording.

Setting recording tracks

Press the RECORD TRACK select keys of the tracks selected in the digital input track menu to ready the tracks for recording.

Recording

<Important!>

Be sure to input a digital signal (S/PDIF or adat) of the same sampling frequency as that used on the recorder.

1. Locate the beginning of the Program.
2. Make sure that the [DIGITAL] and [EXT SYNC] indicators light up on the screen. While pressing and holding down the RECORD button, press the PLAY button to start recording.
3. Play the external digital device.
Make sure that the level meter segments light up and move as the digital signal is being input.

Completing recording

4. After you finish recording, stop the recorder and the connected digital device.

[Clock Sel ?] setting		Int	Auto	Word	Video
SPDIF :Async	clock received from WORD IN	Regardless of receiving or not receiving word clock from WORD IN, the recorder is referenced to the internal clock. When the recorder receives correct digital signals, the [DIGITAL] indicator lights in the display.	When receiving word clock from WORD IN, the recorder automatically synchronizes to the incoming clock, while the [DIGITAL] and [EXT SYNC] indicators light in the display.	When receiving word clock from WORD IN, the recorder synchronizes to the incoming clock, while the [DIGITAL] and [EXT SYNC] indicators light in the display.	Available only when installing the optional Model 8345 TC/SYNC card. If you try to select "Video," [Void w/o Video] is displayed and you cannot select it. See the appendix of the Reference manual for details.
	no clock received from WORD IN		When no word clock is received, the recorder is referenced to the internal clock, while the [EXT SYNC] indicator flashes.	When no word clock is received, the [EXT SYNC] indicator flashes showing that the unit cannot be locked.	
SPDIF :Sync	clock received from WORD IN	Regardless of receiving or not receiving word clock from WORD IN, the recorder synchronizes to the external S/P DIF digital signal. When the recorder receives correct digital signals, the [DIGITAL] and [EXT SYNC] indicators light in the display. When Digital In is set to a SYNC mode, if you try to select [Clock Sel?] menu, The display will show [Clock Sel D.in!] (indicating that the clock is set to Digital In!) and the recorder ignores your operation.			
	no clock received from WORD IN				
adat :Async	clock received from WORD IN	Regardless of receiving or not receiving word clock from WORD IN, the recorder is referenced to the internal clock. When the recorder receives correct digital signals, the [DIGITAL] indicator lights in the display.	When receiving word clock from WORD IN, the recorder automatically synchronizes to the incoming clock, while the [DIGITAL] and [EXT SYNC] indicators light in the display.	When receiving word clock from WORD IN, the recorder synchronizes to the incoming clock, while the [DIGITAL] and [EXT SYNC] indicators light in the display.	
	no clock received from WORD IN		When no word clock is received, the recorder is referenced to the internal clock, while the [EXT SYNC] indicator flashes.	When no word clock is received, the [EXT SYNC] indicator flashes showing that the unit cannot be locked.	
adat :Sync	clock received from WORD IN	Regardless of receiving or not receiving word clock from WORD IN, the recorder synchronizes to the external adat digital signals. When the recorder receives correct digital signals, the [DIGITAL] and [EXT SYNC] indicators light in the display. When Digital In is set to a SYNC mode, if you try to select [Clock Sel?] menu, The display will show [Clock Sel D.in!] (indicating that the clock is set to Digital In!) and the recorder ignores your operation.			
	no clock received from WORD IN				

Digital recording to an external digital device

You can record digital data recorded on the recorder to a connected MD, DAT, CD-R or adat. To do so, select [SP DIF] or [adat] for the tracks that are assigned to the DIGITAL/DATA OUT jack of the recorder. You can record digital data to the current Program. The digital output setup menu is applied globally to all Programs.

<Note>
 Data on the additional tracks cannot be digitally recorded to the external device as it is. To output digital data from the additional track, move it to the real tracks first, then output it to the external device (using the Track Exchange function). For more information on the Track Exchange function, see page "72."

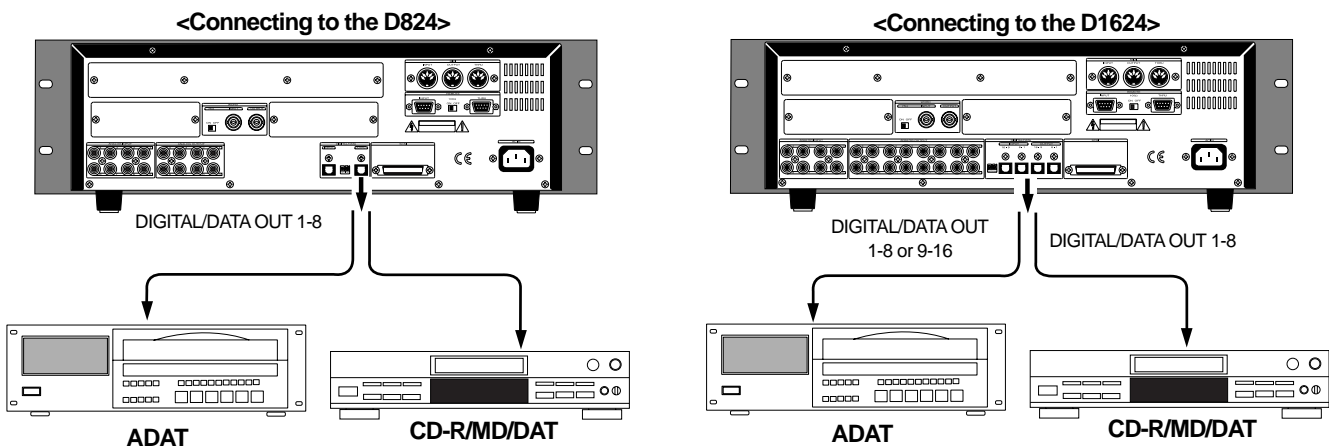

<Note>
 Connecting the recorder to an external digital device via both digital input and output jacks may generate a digital loop. For more information on this problem, refer to the "Connecting a digital mixer" section below.

* If the connected external device has only a COAXIAL (RCA pin) jack for digital input, use an optional Fostex COP-1/96k (optical/coaxial converter).

Connecting an external digital device

1. Use an optical cable to connect the DIGITAL/DATA OUT jack of the recorder to the OPTICAL IN (or adat IN) jack of the external digital device.

Setting the digital output

Use the digital output setup menu in Setup mode to assign output tracks.

With the default setting, the digital output is set to [adat]. You can select [adat] or [SP DIF].

To output adat digital signals to a connected adat device, select [adat]. To output S/P DIF signals to a connected CD-R, MD, or DAT recorder, select [SP DIF].

* See page "114" for more information on the [D. out?] menu.

When you finish setting the parameters in Setup mode, press the EXIT/NO key or the Stop button to exit Setup mode.

<Notes regarding the digital connection>

The DIGITAL/DATA OUT jack of the D824/D1624 can be used either for an S/P DIF digital signal (optical) or for an adat digital signal. You must use the digital output setup menu in Setup mode to select one of them. These signals use the same jack but carry two different types of information.

<When using the D824>

Connect the DIGITAL/DATA OUT 1-8 jacks to the OPTICAL IN (or adat IN) jack of the digital device. If you select [SPDIF] for the digital output tracks, the outputs of tracks 1 and 2 are assigned to Outputs 1-8. If you select [adat] for the digital output tracks, the output of tracks 1-8 are assigned.

<When using the D1624>

To connect the D1624 with a digital device, to output an S/P DIF digital signal, or to output an adat digital signal, use the DIGITAL/DATA IN 1-8 or 9-16 jacks. If you select [SPDIF] for the digital output tracks, the outputs of tracks 1 and 2 are assigned to Outputs 1-8 and the outputs of tracks 3 and 4 are assigned to Outputs 9-16. If you select [adat] for the digital output, the outputs of tracks 1-8 are assigned to Outputs 1-8 and the outputs of tracks 9-16 to Outputs 9-16.

Note that only the DIGITAL/DATA OUT 1-8 jacks can be used on the D1624 when you load the song data. (For more information, see "Saving and Loading Song Data" on page 84.)

Connecting a Digital Mixer

The following explanations assume that this is digital mixer, which can input digital signals whose clock source can be setup at digital in.

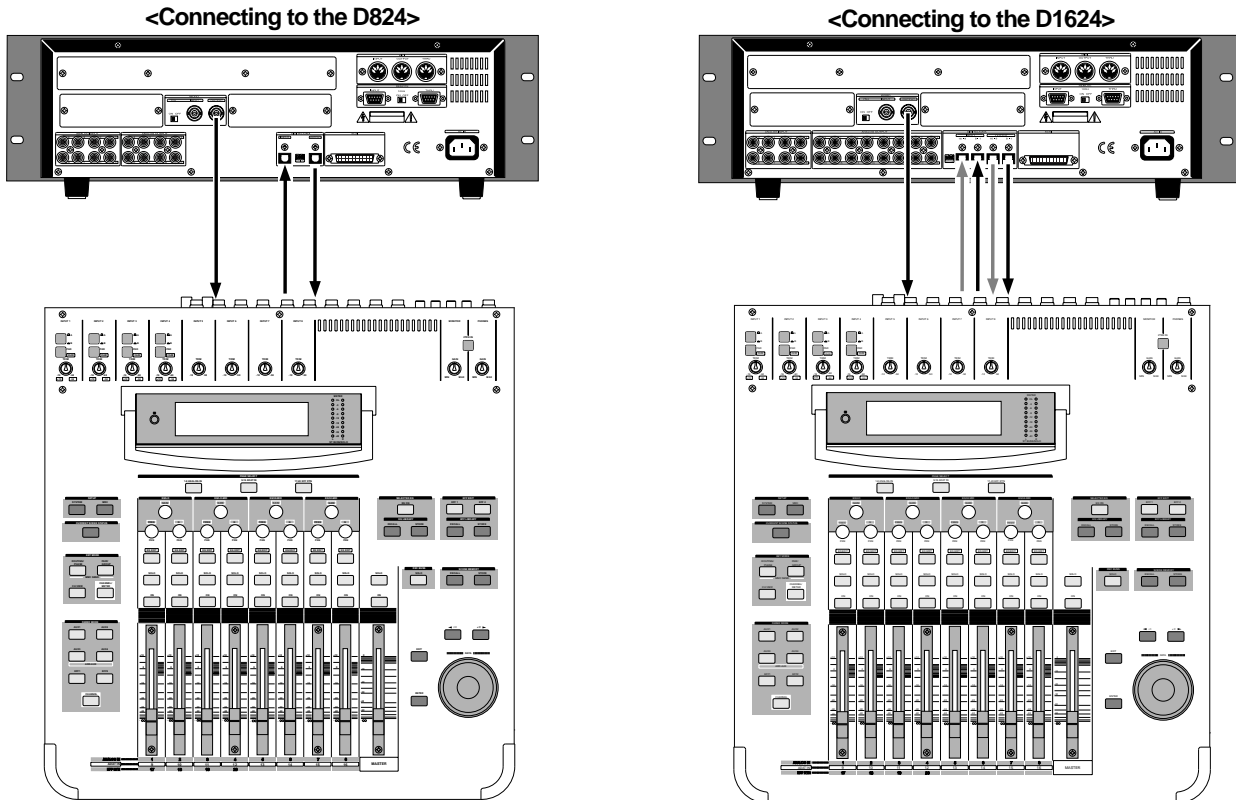

<Precautions in setting the SETUP mode [Clock Sel?] menu when digital recording>

For digital recording in any system which could create a digital loop such as with a digital mixer, set the [Clock Sel?] to the initial setting of [Int.].

<A digital loop>

In a connection between the recorder and a digital mixer as shown below, if the recorder SETUP mode [Clock Sel?] (setting the operating clock) menu is set to [Auto] and the digital mixer clock source is set to "DIGITAL IN," a clock loop is created and the system will not operate correctly. In order to avoid this loop, change either piece of the equipment to INTERNAL clock using the following procedure.

- * Change the recorder SETUP mode [Clock Sel?] menu to the [Int.] setting (internal clock: initial setting).
- * Set the digital mixer clock source to "INT."

Normally, when creating such a system, setting the recorder to INTERNAL ([Clock Sel?] is set to [Int.]) is recommended.

If both pieces of equipment are set to INTERNAL, external sync will be asynchronous and could be the cause of poor sound. For details on setting the SETUP mode [Clock Sel?] menu, refer to page "117."

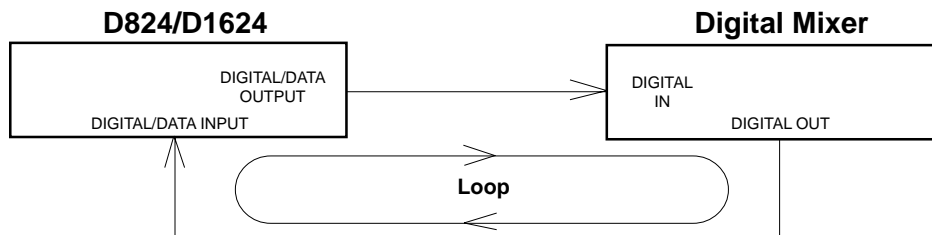

Recording to a Metronome Sound

This chapter explains how to record your performance while you are playing an instrument accompanied by a metronome based on the time signature and tempo specified in the Tempo Map. The metronome sound is output from track 8 on the D824 and from track 16 on the D1624.

- Initialize the recorder before the operation.
- If multiple Programs exist, first select the desired Program.

<Notes>

* With the metronome function ON and the RECORD TRACK select key for the track (track 8 for D824, track 16 for D1624) to which the metronome sound is to be output set to READY, an attempt to record you cannot record to this track. Also, information which had already been recorded on this track cannot be played back.

* Always switch off the Metronome function setting in the SETUP mode after finishing.

<Please remember this!>

In D1624 which had been formatted to 96kHz/24bit (Real track 1-8) the metronome sound will be output from track 16. Therefore, Real tracks 1-8 can all be used for normal recording/playback.

<When using the analog mixer>

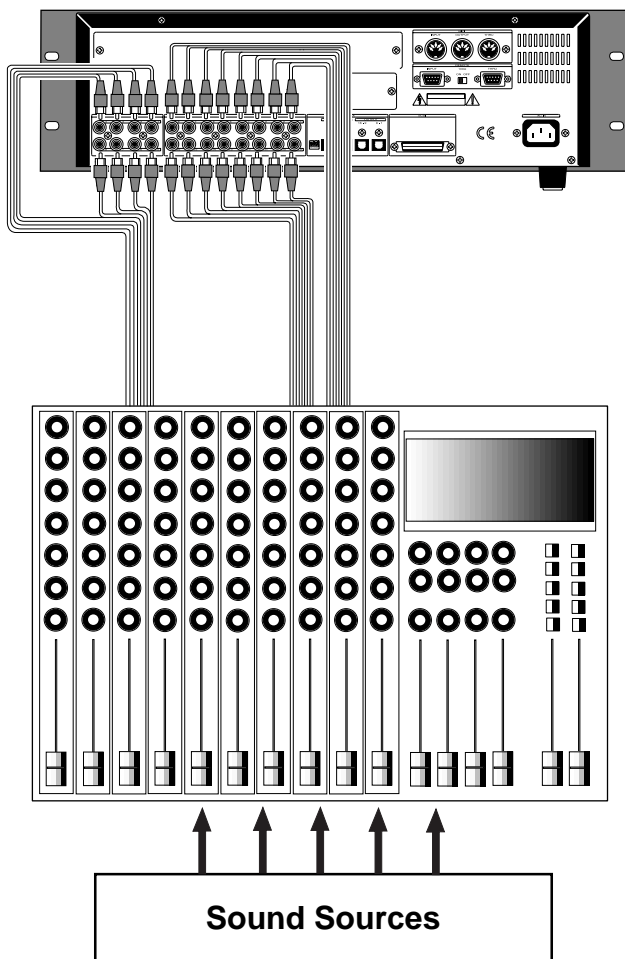

<When using the digital mixer>

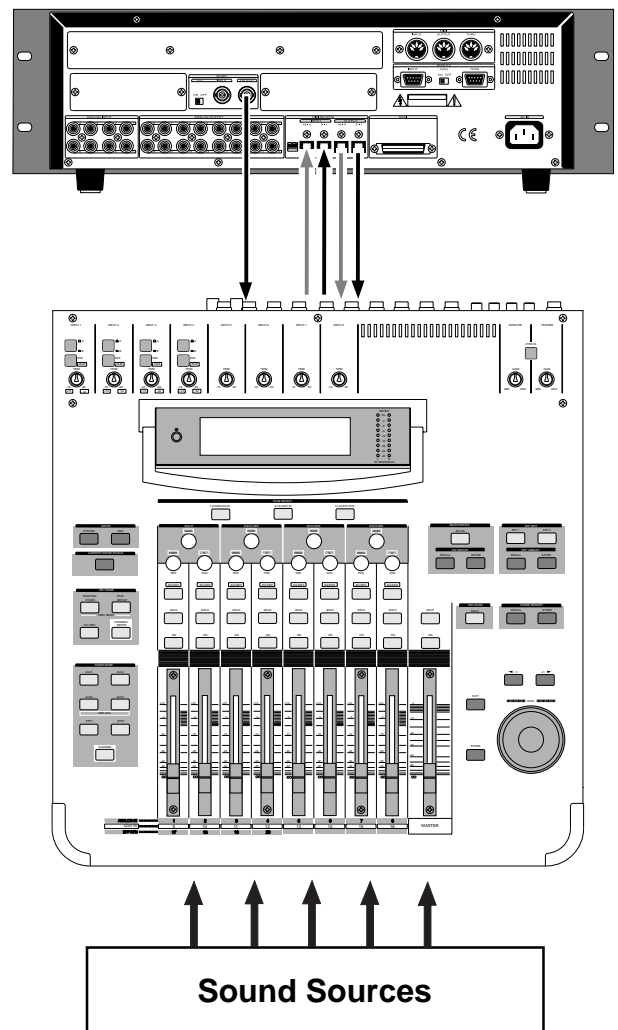

Creating a Tempo Map

- * **Set the time signature using the “Setting a time signature” menu in SETUP mode.**
Refer to the “Setting a time signature” section on page “103.”
- * **Set a tempo for a given point using the “Setting a tempo” in SETUP mode.**
Refer to the “Setting a tempo” section on page “105.”

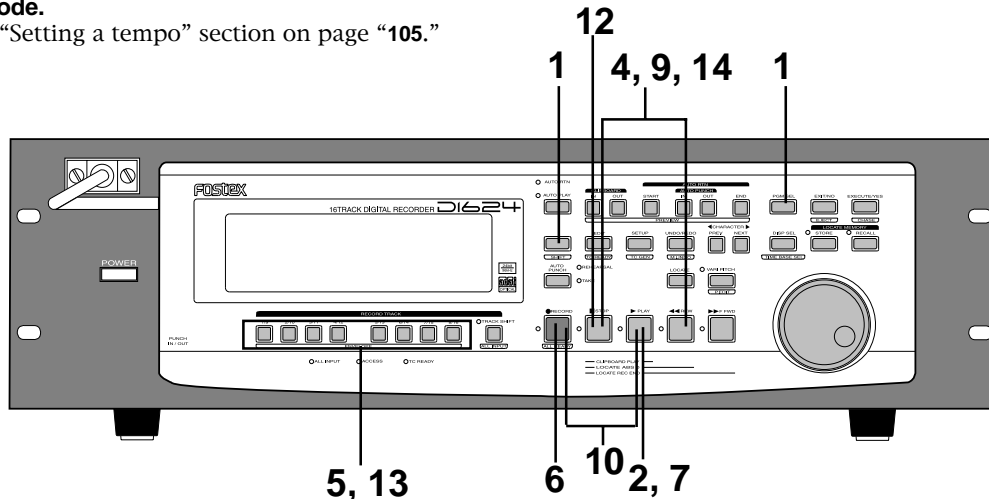

Turning the Metronome function on

- * **Turn the Metronome function on using the “Setting the Metronome function” menu in SETUP mode.**
Refer to the “Setting the Metronome function” section on page “107.”

Checking the metronome sound

1. Press the DISP SEL key while holding down the SHIFT key to switch the time base in advance to BAR/BEAT/CLK.
2. Start playback from the beginning of the Program.
Even if the selected Program does not have any recorded data, track 8 (or track 16) outputs the metronome sound and the unit counts time.
3. Adjust the system so the sound output from track 8 (or track 16) can be monitored with the mixer.
You will hear the metronome sound output from track 8 (or track 16) using the Tempo Map created earlier.
4. After confirming the metronome sound, stop the recorder section and return to the top Program.

Adjusting monitor/record level of the musical instrument

5. Press the RECORD TRACK select key of the track to record the musical instrument on, and then put that track in the READY mode.
6. Press the RECORD button.
The LED of the RECORD button will flash and the READY track will go to the input monitor mode.
7. Press the PLAY button and playback the Program from the top.
Only the READY track will go to the input monitor mode (recording does not take place), and all other tracks will be in the reproduction monitor mode, therefore track 8 (or track 16) plays back the metronome sound.
8. Play the musical instrument in time with the metronome and adjust the recording level of the track to be recorded on the mixer.

9. After adjusting the recording level, stop the recorder and return to the top of the Program.

Starting recording

10. Hold down the RECORD button and press the PLAY button to start recording.
The READY track will go to the input monitor mode just as when the recording level was adjusted. The time the level that was actually adjusted with the mixer will be recorded.
11. Play the musical instrument in time with the metronome.

Quitting recording

12. Press the STOP button to stop the recorder.

Checking the recorded sound

13. Turn OFF the ready track RECORD TRACK select key .
14. Locate the top of the Program and start playback.
Adjust and monitor the track playback sound recorded on the mixer. Since the metronome function still remains ON at this time, you can hear the metronome sound during playback of the recorded sounds when you turn up the track 8 (or track 16) monitor volume.

• If you wish to redo the recording, repeat the recording after executing “undo” by using the single undo/redo or multiple undo functions.

Storing a Locate Point (Edit Point)

You can store specific individual time data (time, bar/beat/clock) in each memory key (*). The time data stored is used as an “Editing Point” to execute “Locate Point” or Auto Punch In/Out, Copy & Paste, Move & Paste or Erase. You can also store 99 (Locate Number 01-99) time data in the LOCATE key, in addition to the Memory key, to enable locate only features. This chapter will describe how to store specific data in the memory key and how to edit and re-store data is already stored in the memory key. The data stored in each memory are used for the following operations.

* Memory key

When you set the IN/OUT points for Auto Punch In/Out, IN/OUT points for Copy & Clip/Move & Clip, and START/END points for Auto Return/Auto Repeat, END points.

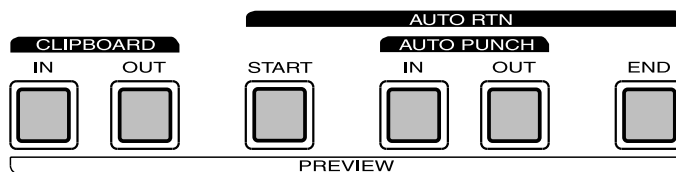

AUTO PUNCH IN key	<ul style="list-style-type: none"> * Locating the AUTO PUNCH IN point. * Recording start point for the Auto Punch In/Out operation. * Paste start point for the Copy & Paste or Move & Paste operation. * Erase start point for the Erase operation.
AUTO PUNCH OUT key	<ul style="list-style-type: none"> * Locating the AUTO PUNCH OUT point. * Recording end point for the Auto Punch In/Out operation. * Erase end point for the Erase operation.
CLIPBOARD IN key	<ul style="list-style-type: none"> * Locating the CLIPBOARD IN point. * Copy start point for copying or moving data to the clipboard during the Copy & Paste or Move & Paste operation.
CLIPBOARD OUT key	<ul style="list-style-type: none"> * Locating the CLIPBOARD OUT point. * Copy end point for copying or moving data to the clipboard during the Copy & Paste or Move & Paste operation.
AUTO RTN START key	<ul style="list-style-type: none"> * Locating the AUTO RTN START point. * Locate end point from AUTO RTN END in Auto Return or Auto Repeat modes.
AUTO RTN END key	<ul style="list-style-type: none"> * Locating the AUTO RTN END point. * Locate start point to AUTO RTN START in Auto Return or Auto Repeat modes.

<Note on storing the locate point>

When you set the IN/OUT points for Auto Punch In/Out, IN/OUT points for Copy & Clip/Move & Clip, and START/END points for Auto Return/Auto Repeat, make sure that IN points precede the OUT points and START points precede the END points.

You can also store time data in the LOCATE key, in addition to each memory key explained above. You can store up to 99 individual time data in the LOCATE key for locate only features. Store the data by specifying Locate Number to locate the intended time data. Note that the LOCATE key always stores the last located time data in real-time. This Locate Number is stored as 00, and does not require a Locate Number specification to locate it. Simply pressing the LOCATE key directly, will locate that data. This becomes an advantage since it is possible to repeatedly locate the last located point. You can edit the data stored in the LOCATE key, as so with the data stored in the Memory key. For more details refer to page “55.”

- * You can store locate points for each Program. (You need to select a Program first.)
- * When executing save/load of song data via SCSI, these data can be directly saved/loaded. Save/load by DAT and adat cannot be done.
- * All locate points stored in the memory keys will be maintained after you turn off the recorder.

Storing and editing the locate points to the memory keys

- Select the desired Time Base using the DISP SEL key and EXECUTE/YES key as if you wish to use a Time Base other ABS.
- The stored or edited locate points are used only in the currently-selected Program.

Storing in real-time

You can store the locate point (in the ABS, MTC, or BAR/BEAT/CLK Time Base) in real-time while the recorder is playing.

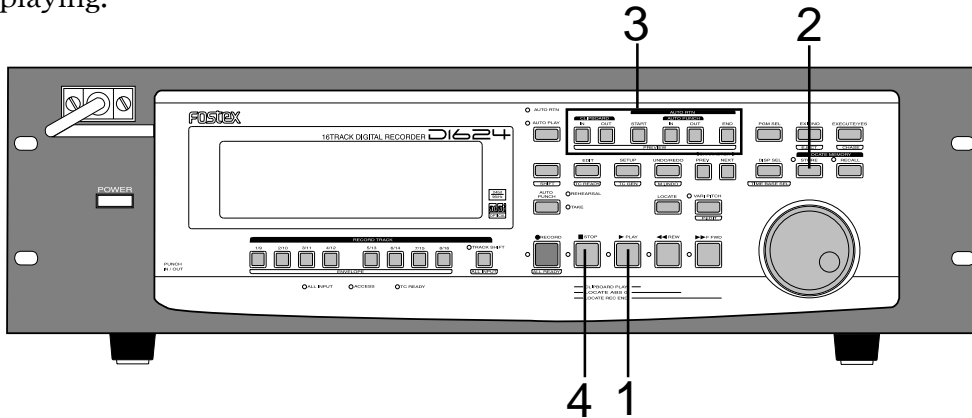

1. Press the PLAY button to play back data.

2. When the point you wish to store is reached, press the STORE key.

The time value or bar/beat/clock value of the point is captured. The recorder enters data edit mode.

<Note>

The following menu (##=number from 00-99) appears when pressing the STORE key. This menu is used to store data in the LOCATE key, described later. Ignore this menu and go to the next step when storing data in the memory key.

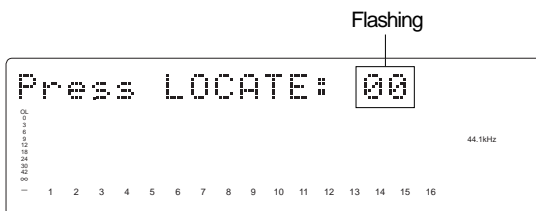

3. Press the desired memory key.

The STORE LED turns off.

The captured time value (or bar/beat/clock value) is stored in the memory key. After the data is stored, the recorder displays the previous Time Base and continues playback.

4. Press the STOP button.

<Please remember this!>

- If you set "BAR/BEAT Resolution mode" in SETUP mode to ON, the recorder will round off the CLK value of the captured bar/beat/clock value. That is, the locate point will be at the beginning of the beat (00). Refer to page "415" for more information.

- When pressing the STORE key in step 2, if the STORE key is pressed while holding down the SHIFT key, data to be registered will be held and be confirmed. To register data after confirmation, press the STORE key again and press the desired memory key.

Editing and storing data

You can recall data stored in the memory key, edit it, and store it again.

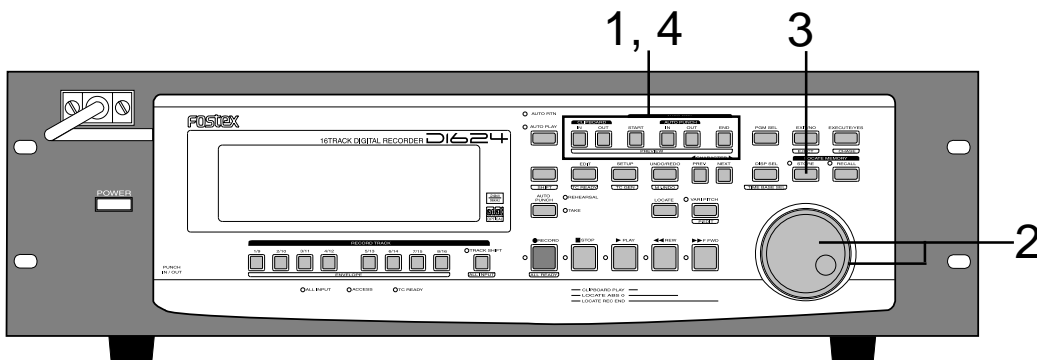

1. While the recorder is stopped, press the memory key that stores the data you wish to edit.

The stored data appears on the display and the recorder enters data edit mode.

2. Turn the SHUTTLE dial to move the flashing cursor to the time value digit, and use the JOG dial to increase or decrease the value.

3. Press the STORE key.

The [Press LOCATE: ##] menu will appear as indicated before. Ignore this go to the next step.

4. Press the memory key that you pressed in Step 1 again.

The STORE LED will turn off. The edited data is stored, and the recorder displays the previous Time Base indication.

- You can store the edited data in a memory key other than the one you pressed when you recalled the data. For example, you can recall the AUTO PUNCH IN point data, edit it, and store it to the AUTO PUNCH OUT key.
- You can also use the Preview function to edit the stored locate points (edit points). Refer to "Preview Function" on page "63" for more information.

- Refer to page "39" for more information on Auto Punch In/Out.
- Refer to page "66" for more information on Copy & Paste, Move & Paste, and Erase.
- Refer to page "58" for more information on Auto Return and Auto Repeat.

Storing and editing LOCATE key

You can store up to 99 individual time data in the LOCATE key for Locate only operations. The time data stored can also be assigned with a specific locate number from 01-99. This means the desired locate number can be specified to locate that specific time data. The memory data of the LOCATE key can also be edited in the same manner as the data in the Memory key. After editing the data the LOCATE key can locate that point, or even be re-stored as data for other Memory keys.

- <Notes>**
- * The last data located with the Memory key or LOCATE key is constantly stored as LOCATE number 00. However, this data is constantly replaced after every LOCATE command. Therefore, do not use Locate Number 00 for independent Locate data.
 - * You cannot preview the data stored in the LOCATE key, though it is possible to preview data stored in other Memory keys.

- * If you use a time base that is not an ABS time, there is a need to priory switch to the desired time base using the SHIFT key and EXECUTE/YES key.
- * Any editing or storing of data for the LOCATE point is valid only for the program that is currently started up.

Storing in real-time

You can store the locate point (in the ABS, MTC, or BAR/BEAT/CLK Time Base) in real-time while the recorder is playing.

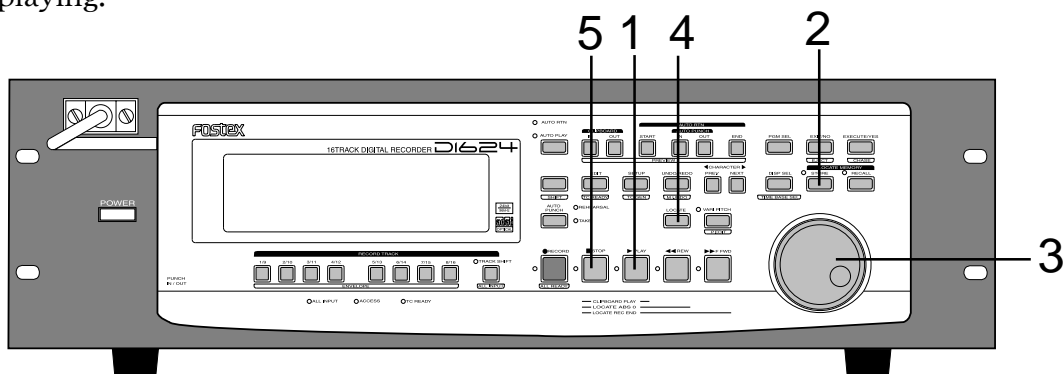

1. Press the PLAY button to start playback.

2. Press the STORE key (the STORE LED lights up).

The memory number selection menu will appear, as follows.

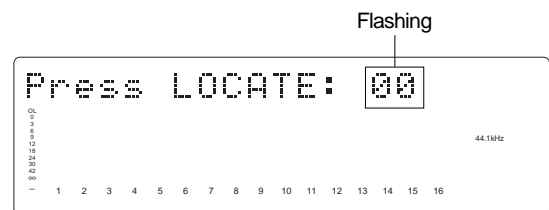

3. Select the LOCATE number desired using the JOG dial.

LOCATE number from 00-99 are selectable. However, select a number other than 00.

4. Next press the LOCATE key.

The time base (or bar/beat/clock) put on hold is stored as data in the LOCATE number selected. The system will return to the original time base when the storage process is completed, and playback is resumed.

5. After completing the store process, press the STOP button to stop the recorder section.

<Please remember this!>

- If you set "BAR/BEAT Resolution mode" in SETUP mode to ON, the recorder will round off the CLK value of the captured bar/beat/clock value. That is, the locate point will be at the beginning of the beat (00). Refer to page "115" for more information.
- When pressing the STORE key in step 2, if the STORE key is pressed while holding down the SHIFT key, data to be registered will be held and be confirmed. To register data after confirmation, press the STORE key again and press the desired memory key.

Edit and re-store data that is already stored

RECALL the desired time data already stored in the LOCATE key, edit that data and re-store it.

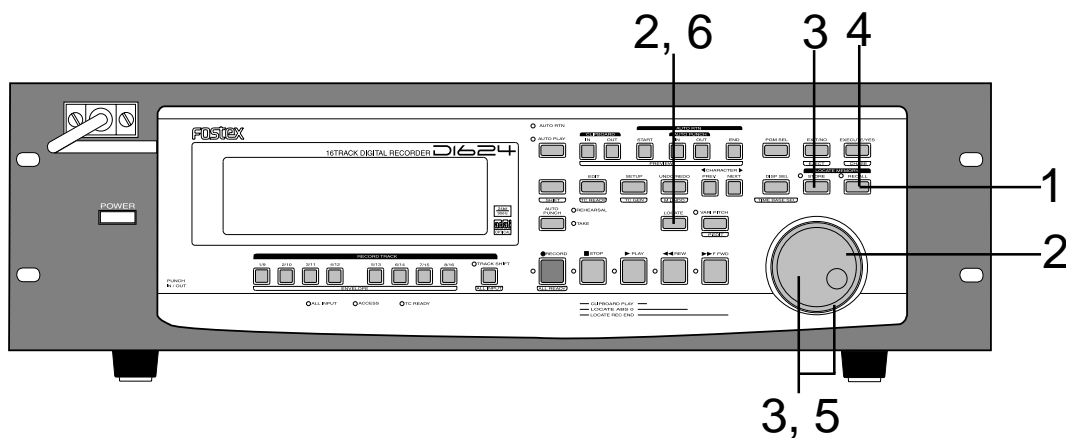

1. Press the RECALL key while the recorder is stopped.

The menu to select the LOCATE number will appear.

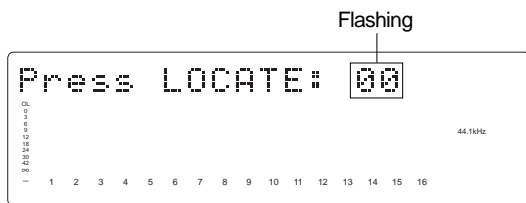

4. Press the STORE key (the STORE LED lights up).

The LOCATE number selection menu to store data will appear.

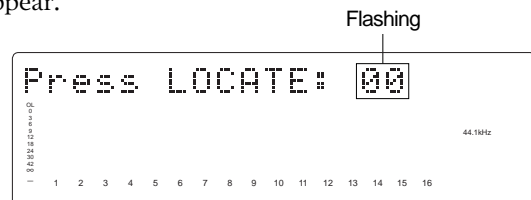

2. Turn the JOG dial to select the desired LOCATE number, then press the LOCATE key.

The data edit mode will appear when the data stored in the selected LOCATE number appears.

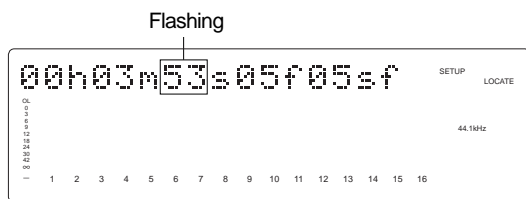

- If the STORE key is press instead of the LOCATE key at this stage, it becomes possible to directly LOCATE the time data of the selected LOCATE number. For more details refer to the next section on "Location Functions."

5. You can use the JOG dial to input the desired LOCATE number.

6. Press the LOCATE key.

The edit time data is stored as the time data for the selected LOCATE number.

3. Turn the SHUTTLE dial to move the (cursor) column of the time indication to edit (cursor flashing point), increase or decrease the number setting with the JOG dial or input the desired time base.

Locate Function

The recorder swiftly locates (it moves the current location of the recorder section) the desired point when necessary. Locate include edit points (in ABS time, MTC time, or in bar/beat/clock) that are stored for the Copy, Move, Paste, Erase, or Auto Punch In/Out operations.

They also include Locate by specifying a voluntary time, and Locate specifying a voluntary Locate Number (01-99), as well as Locate directly to the recording end point in a Program (REC END). An application of the Locate function includes auto functions such as Auto Play, Auto Return and Auto Repeat.

Direct Locate

The Direct Locate function enables you to locate the following points:

• Locate the beginning of the Program (LOCATE ABS 0)

Press the **REWIND** button while holding down the **STOP** button.

The recorder will immediately locate the beginning of the currently-selected Program.

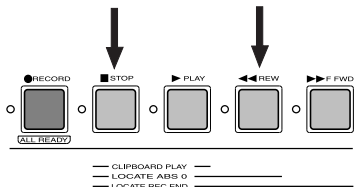

• Locate the recording end point of the Program (LOCATE REC END)

Press the **F FWD** button while holding down the **STOP** button.

The recorder will immediately locate the end point of the currently-selected Program.

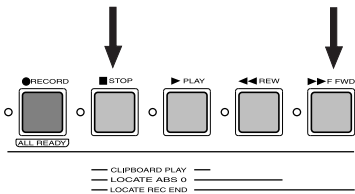

• Locate the position stored in one of the memory keys

Press the desired memory key, then press the **LOCATE** key.

The recorder will locate the point (edit point) stored in the corresponding memory key immediately.

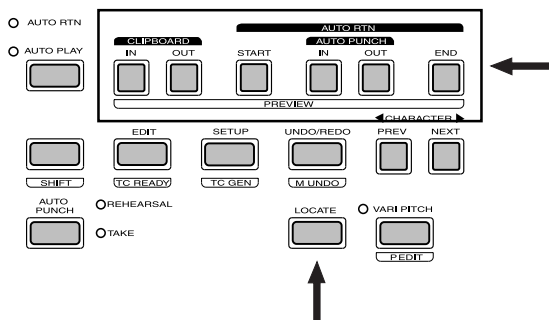

The located time data is always stored as time data in Locate Number 00.

• Specify the Locate Number to locate data



1. Press the **RECALL** key.

The Locate Number selection menu appears.



2. Turn the **JOG** dial or press the **NEXT** key/**PREV** key to select the desired number.



3. Press the **LOCATE** key once.

The time stored in the selected Locate Number appears.

4. Press the **LOCATE** key again.

The time data of the selected LOCATE number is swiftly located. The located time data is constantly stored as time data in Locate Number 00.

• Locate a specified point

Refer to “Editing and storing locate data” in the chapter “Storing a Locate Point (Edit Point)” for information on how to edit the data and on pressing the **LOCATE** key instead of the **STORE** key.

The point at specified time value (or bar/beat/clock value) will be located immediately.

• Locate the last-located point

Directly press the **LOCATE** key.

The time data of Locate number 00 is located. Locate number 00 is always update with the last data located (excluding LOCATE ABS 0 and LOCATE REC END). Therefore, you will locate the data in memory number 00 every time you directly press the LOCATE key.



Auto Play function

The Auto Play function allows the recorder to start play back automatically from the located point. AUTO PLAY mode should be turned on before you execute the Direct Locate function described above.

<Note>
 This function is effective within 24 ABS hours. Therefore, if playback continues over the recording end point, the recorder will still continue counting the time. Also, when the recorder locates ABS REC END, it will continue counting the time from the recording end point. (However, the unit does not access the disk after reaching the recording end point.)

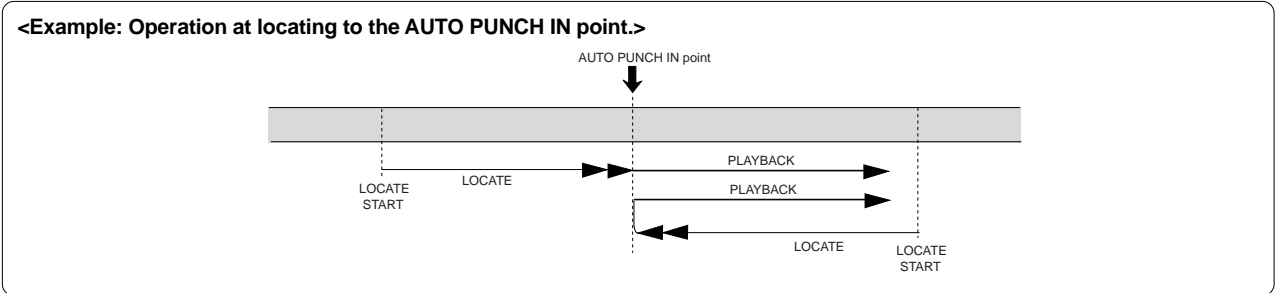

1. Press the AUTO RTN/AUTO PLAY key to turn on the [AUTO PLAY] LED.

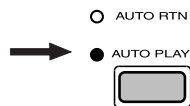

2. Press the LOCATE key, or memory key.
 The recorder locates the point and plays as shown in the diagram.

3. Press the STOP button to stop the unit.

• You can set a preroll time in the [Preroll Time ?] menu in SETUP mode so that the recorder will start playback preroll time before the locate point. You can set the preroll time from 0 to 10 seconds. Refer to the chapter “Changing the Initial Settings (SETUP Mode)” on page “108.”

Auto Return function

This function allows the recorder to play data up to the AUTO RTN END point, then automatically locate the AUTO RTN START point as shown in the diagram below. To enable this function, AUTO RTN mode should be on and the AUTO RTN START point and AUTO RTN END point should already be set.

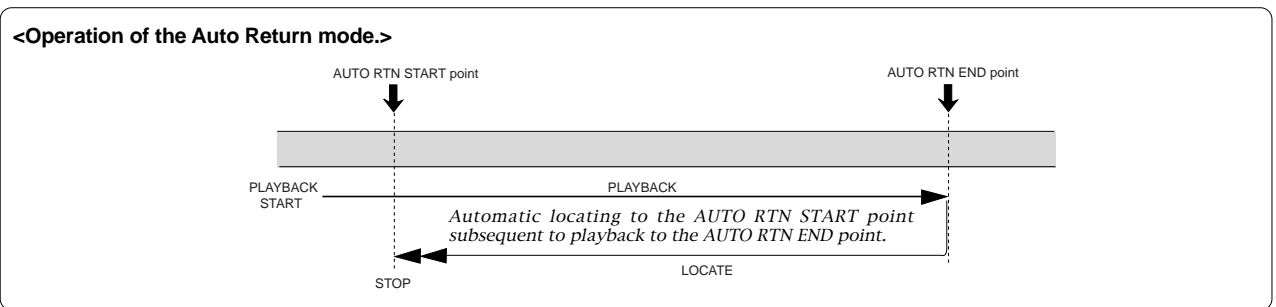

1. Store the AUTO RTN START and AUTO RTN END points.

Refer to the chapter “Storing a Locate Point (Edit Point)” on page “54” for information on storing the desired points in the AUTO RTN START key and the AUTO RTN END key.

2. Press the AUTO RTN/AUTO PLAY key to turn on the [AUTO RTN] LED.

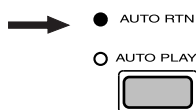

3. Start playback a little before the AUTO RTN END point.

The recorder operates as shown in the diagram.

• You can set a preroll time in the [Preroll Time ?] menu in SETUP mode so that the recorder will start playback preroll time before the locate point. You can set the preroll time from 0 to 10 seconds. Refer to the chapter “Changing the Initial Settings (SETUP Mode)” on page “108.”

Auto Repeat function

The Auto Repeat function allows the recorder to repeat playback up to the AUTO RTN END point, automatically locate the AUTO RTN START point, then play up to the AUTO RTN END point until you cancel the function by pressing the STOP button. To enable this function, both AUTO PLAY mode and AUTO RTN mode should be turned on, and the AUTO RTN START point and the AUTO RTN END point should already be set. Using this function will facilitate the Auto Punch In/Out and Manual Punch In/Out rehearsal. See “Hint” after the following section.

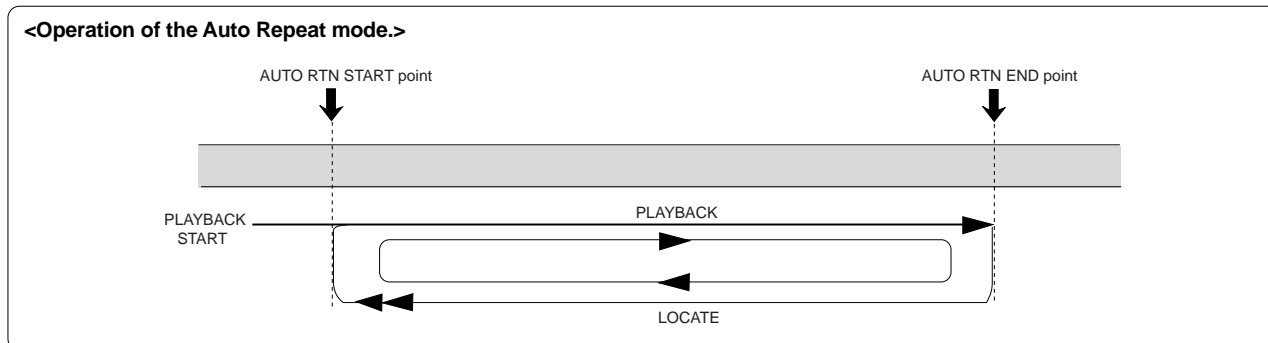

1. Store the AUTO RTN START and AUTO RTN END points.

Refer to the chapter “Storing a Locate Point (Edit Point)” on page “54” for information on storing the desired points in the AUTO RTN START key and the AUTO RTN END key.

2. Press the AUTO RTN/AUTO PLAY key to turn on the [PLAY RTN], [AUTO PLAY] LEDs.

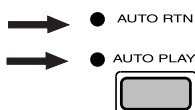

3. Start playback a little before the AUTO RTN START point.

The recorder operates as shown in the diagram, and stops at the AUTO RTN START point.

- You can set a preroll time in the [Preroll Time?] menu in SETUP mode so that the recorder will start playback preroll time before the locate point. You can set the preroll time from 0 to 10 seconds. Refer to the chapter “Changing the Initial Settings (SETUP Mode)” on page “108.”

<Hint>

You can make repeated Auto Punch In/Out rehearsal much easier and quicker by using the Auto Repeat function.

Set the AUTO RTN START point prior to the AUTO PUNCH IN point, and set the AUTO RTN END point after the AUTO PUNCH OUT point. The recorder will repeat the operation automatically so you can concentrate on your rehearsal.

Cancel Auto Repeat mode before you record a take.

The recorder will play this range repeatedly for rehearsal, which makes it easy for you to check the recording level and practice your performance.

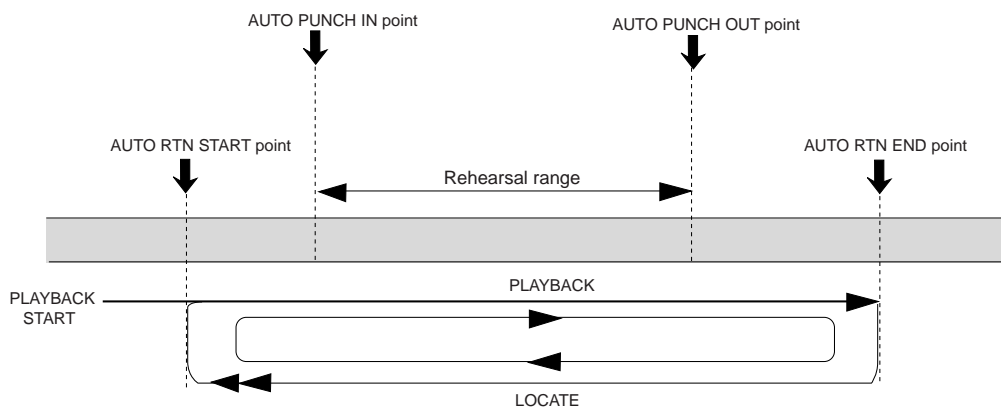

Cue & Review Function

This chapter explains how to use the “Cue & Review” function with the REWIND button, the F FWD button, and the SHUTTLE dial, and also explains “Digital Scrubbing” with the envelope function. During Cue/Review and Digital Scrubbing you will hear the sound recorded on the disk, which makes it easy for you to swiftly locate the desired point without failure while listening to the sounds.

The prerequisite of the following operation is that the time base is ABS, however, the operation can be executed in any time base. To execute this function with a non-ABS time base there is a need to priority switch over to the desired time base.

Cue & Review function using the REWIND and F FWD buttons

You may cue & review the audio data at five-times speed while the recorder is playing.

1. Press the **PLAY** button to play the audio data.
2. Press the **F FWD** button during playback.
This cues in the forward direction at five-times speed. The **PLAY** LED and **F FWD** LED lights up while cueing is taking place.
3. Adjust the monitor sound of the track to monitor on the mixer.
4. Press the **PLAY** button again to restore the original playback speed.
5. Press the **REWIND** button instead of the **F FWD** button.
This cues in the rewind direction at five-times speed. The **PLAY** LED and **REWIND** LED lights up while cueing is taking place.
6. Press the **PLAY** button to restore the original playback speed.

Cue & Review function using the SHUTTLE dial

You can use the SHUTTLE dial for +1~-7 times or -1~-8 times

1. Press the **PLAY** button to start playback.
2. Turn the **SHUTTLE** dial clockwise during playback.
The forward direction cue speed varies from +1~ -7 times speed depending on the degree (angle) of turning the dial. **PLAY** LED flashes and **F FWD** LED lights up during the cue process.
3. Adjust the monitor sound of the track to monitor on the mixer.
4. Let go of the **SHUTTLE** dial to return to normal play speed.
5. Similarly, turn the **SHUTTLE** dial counterclockwise during playback.
The rewind direction review speed varies from -1~ -8 times speed depending on the degree (angle) of turning the dial. **PLAY** LED flashes and **REWIND** LED lights up during the review process.
6. Let go of the **SHUTTLE** dial to return to normal play speed.

Digital scrubbing using the envelope function

You may perform digital scrubbing using the “Envelope Function” of the recorder while the recorder is stopped. The envelope function allows digital scrubbing for each track recorded. The display will show the envelope indication of the track selected.

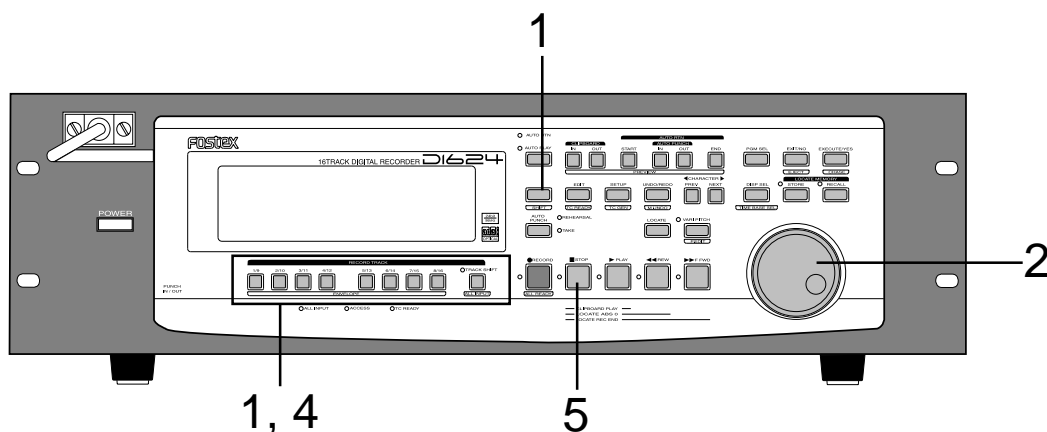

1. While the recorder section is stopped, depress the **SHIFT** key and then press the **RECORD TRACK** select key of the desired record track.

This turns ON the envelope function.
 The envelope indication of the selected track will appear on the display. The following example shows the indication of track 4 envelope, after RECORD TRACK select key [4/12] is pressed. At this time the recorder is in the STILL status (scrub mode is in still status) and the REWIND LED and F FWD lights up.

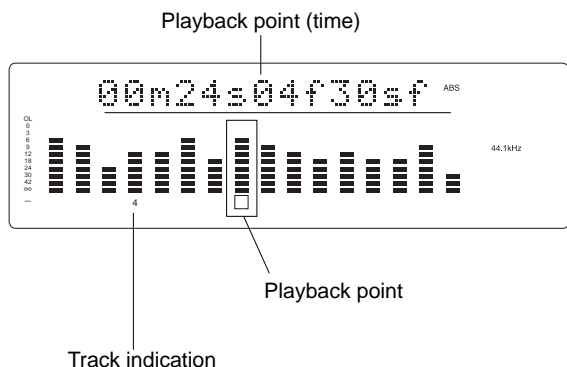

2. You can use the **JOG** dial to digitally scrub the performance of the track selected.

The envelope of the performance recorded on the track varies in real-time. During forward direction scrub the F FWD LED lights up, and during rewind direction scrub the REWIND LED lights up.

3. Adjust the monitor sound of the selected track so that it can be monitored on the mixer.

4. Press the **RECORD TRACK** select key of the desired record track to select another track.

[Please Wait!] will briefly appear and then go to the envelope indication of the selected track.
 The following example shows the case when the indication is switched from track 4 to track 8.

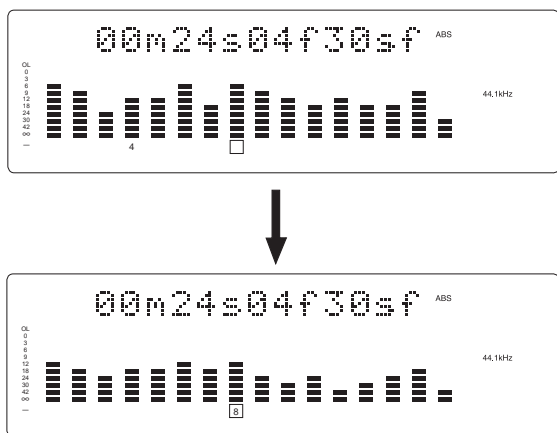

5. Press the **STOP** button to stop the envelope function.

Doing so will turn OFF the envelope function.
 The recorder will return to the time base indication prior to turning the envelope function ON.

Preview Function

The preview function enables you to repeatedly audition the rise (fade in) or the fall (fade out) of the sound data at a locate point (edit point) that is stored in the AUTO PUNCH IN/OUT, AUTO RTN START/END, or CLIPBOARD IN/OUT key. This is also called “point rehearsal.”

With this function, you can check the locate points in real-time. You can also use this function to fine-tune the position of the locate points while previewing the sound. This function is effective only when the recorder is stopped.

• Previewing the rise of the sound (fade in)

While holding down the SHIFT key, press the AUTO RTN START key, the AUTO PUNCH OUT key, or CLIPBOARD IN key.

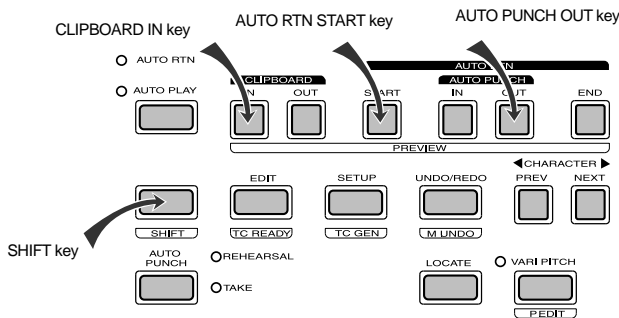

• Previewing the fall of the sound (fade out)

While holding down the SHIFT key, press the AUTO RTN START key, the AUTO PUNCH IN key, or the CLIPBOARD OUT key.

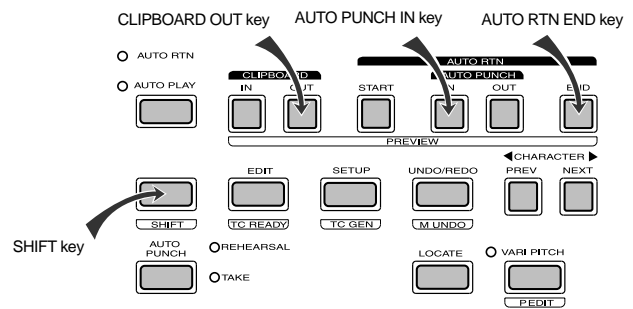

<Display indication during the Preview operation>

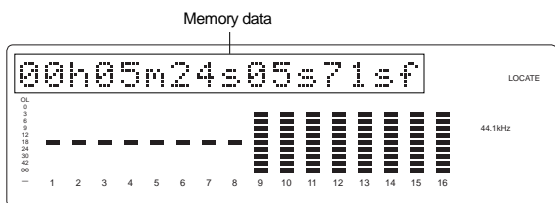

During operation, the meter display will light up from left to right.

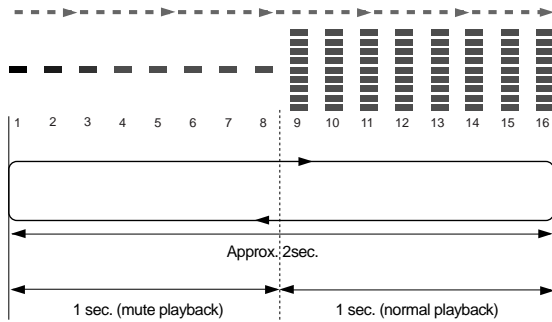

The sound rises at the memory point.

The recorder repeats playback the “rise sound” at the locate point (edit point). As shown in the diagram, one-second of data prior to the locate point is muted during playback. The mute is off (fade in) at the locate point and the sound is played back for one second. The recorder will repeat this operation until you quit the Preview function.

<Display indication during the Preview operation>

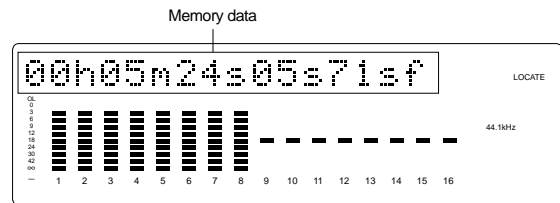

During operation, the meter display will light up from left to right.

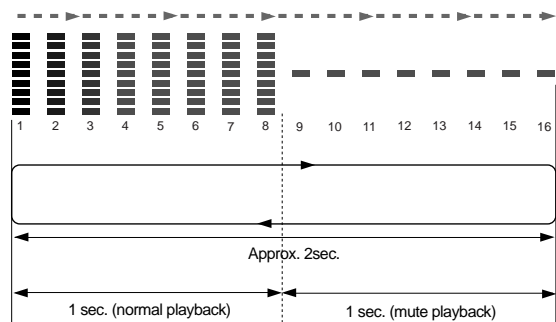

The sound falls at the memory point.

The recorder repeats playback of the “fall sound” at the locate point (edit point). As shown in the diagram, one-second of data prior to the locate point is played back, then muted (fade out) at the locate point. The muted playback continues for one second. The recorder will repeat this operation until you quit the Preview function.

Executing the Preview function

1. Press the desired memory key while holding down the SHIFT key when the recorder is stopped.

Pressing the desired memory key will enable you to preview the sound at the locate point (edit point) stored in the corresponding memory key.

Memory key	Operation
AUTO PUNCH IN key AUTO RTN END key CLIPBOARD OUT key	The recorder plays the fall (fade out) of the sound at the locate point stored in the keys.
AUTO PUNCH OUT key AUTO RTN START key CLIPBOARD IN key	The recorder plays the fall (fade in) of the sound at the locate point stored in the keys.

2. Adjust the monitor sound of the selected track so that it can be monitored on the mixer.

<Note>

If data stored in each memory key is in the initial state, all memory keys will be in ABS time 00h 00m 00s. In other words, the program head value is in the memory. Should fade out preview be executed in this condition, the [Void Data !] message and memory data [00h 00m 00s] will alternately flash in the display as a warning. However, for fade in preview, this will function as the memory data [00h 00m 00s] point.

3. Press the STOP button or the EXIT/NO key.

Trimming the sound while previewing

You can trim the position of the locate point (edit point) using the JOG dial while you preview the sound. At this time, you can also adjust the size of the trimming steps (the amount of offset controlled by the JOG dial).

Trimming allows you to fine-tune the position of the locate point stored in the memory keys while previewing the sound. Use this function to change the Auto Punch In/Out points, the start point of Copy & Paste and Move & Paste, and the start and end points of the Erase function.

<Notes>

- You can audition the result of trimming during the next preview. That is, if you trim the position while previewing the sound for the first time, you can check the result when you preview the sound next time.
- If the locate point is shifted outside the range of the preview playback as a result of trimming, [Void Data!] and the locate point indication appear alternately. In this case, you cannot use the Preview function. Trim the position again so that it will be within the playback range.
- When Auto Punch mode is turned on and you trim the Auto Punch In or Auto Punch Out point while previewing the sound with [Void Data!] indicated on the display, Auto Punch mode will be cancelled.

1. Start previewing the sound by following the steps described on the previous page.

2. Use the JOG dial to trim the position.

When previewing starts, the unit of JOG trimming flashes on the screen.

For example, value of SF (sub-frame) flashes if ABS Time Base or MTC Time Base is selected. CLK (clock) flashes if BAR/BEAT/CLK is selected. The flashing value also indicates the position you can trim.

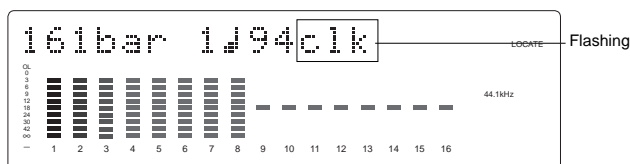
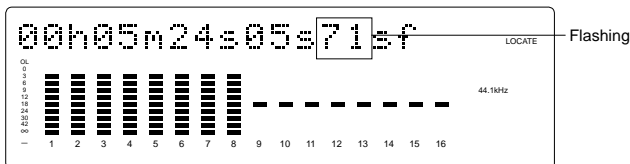

3. To change the unit of trimming, turn the SHUTTLE dial.

These key or dial will change the trimming unit as follows:

	Time base	
	ABS or MTC	BAR/BEAT/CLK
SHUTTLE dial (clockwise)	SF → H → M → S → F	CLK → BAR → J
SHUTTLE dial (counter clockwise)	SF ← H ← M ← S ← F	CLK ← BAR ← J

4. Trim the position at the selected unit (digit).

5. Press the STOP button or the EXIT/NO key.

The trimmed locate point (edit point) data will be stored in the corresponding memory key.

Multiple Undo Function

To undo recordings or edits, you can use the Multiple Undo (Time Jump) function (explained in this section) as well as the Single Undo/Redo function (explained in the Quick Operation Guide and the “Punch in/out” and “Track editing” sections of this manual). You can use the Multiple Undo (Time Jump) function only for a current drive disk that was formatted with the Multiple Undo turned on. (See page xx for more information on the format operation.)

The Single Undo/Redo function enables you to undo and redo the current take of recording or edit (Punch in/out, Copy & Paste, Move & Paste, Erase). However, if you record a new take, you will no longer be able to apply the Undo/Redo function to the previous take.

On the other hand, the Multiple Undo (Time Jump) function can be applied to all takes made after the current drive disk is formatted. To undo a take, select the date and time (at which you finish making the corresponding take) of the edit based on the internal clock.

When you finish recording or editing a take on a current drive disk that was formatted with the Multiple Undo function turned on, that take will get the time stamp of the internal clock (e.g.: [10:50.37 11.Dec?]). Therefore, you can always recall the desired take. This is quite different from the Single Undo/Redo function.

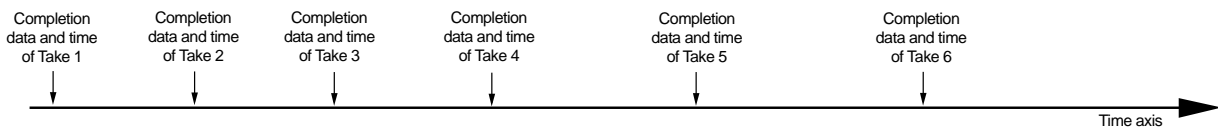

<Notes regarding the Multiple Undo operation>

- * The time stamp of each take references to the internal clock of the recorder. Therefore, after formatting the current drive disk, be sure to set the internal clock correctly. Refer to the Quick Operation Guide for more information on how to set the internal clock.
- * Recording (or editing) more takes will consume more disk space on a current drive disk that was formatted with the Multiple Undo function turned on. This is because more disk space is required to enable the Undo function for any take. Therefore, such a current drive disk with a smaller capacity may not have enough disk space to perform the Multiple Undo function. In this case, performing the disk optimization in Setup mode may increase the free space available for the Undo function. (For more information, see the “Helpful Tips” on page 65.)
- * If you use the Multiple Undo function, you cannot use the Single Undo/Redo function.
- * If you try to use the Multiple Undo function on a current drive disk that was formatted with the Multiple Undo function turned off, the recorder displays [Void!] and ignores your operation.

Using the Multiple Undo function

1. While the recorder is stopped, press and hold down the SHIFT key and press the UNDO/REDO key.

The recorder displays the date and time of a take (as shown below), and [?] and [SURE ?] flash. To select the date and time for another take, turn the JOG dial.

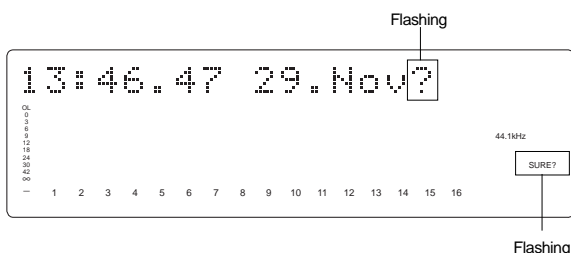

2. Use the JOG dial or the NEXT key and PREV key to select the desired date and time, and press the EXECUTE/YES key.

The recorder displays “MultipleUndo” momentarily, performs the Undo function, and recalls the time base indication that was shown before the function was performed. [COMPLETED!] lights up on the screen.

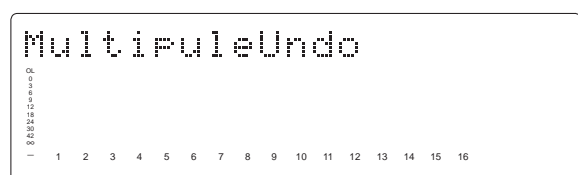

3. Press the EXIT/NO key or the STOP button.
[COMPLETED!] turns off.

<Helpful Tips>

To increase the free space on the disk available for the Multiple Undo function, optimize the current drive disk using the [Disk Optimize?] menu in Setup mode. However, remember that if you optimize a current drive disk that recorded several takes, only the most recent take will remain and other takes will be erased. If you wish to keep other takes, follow the procedure below, then optimize the disk.

<Keeping only one take>

*** First, apply the Multiple Undo function to the take you wish to keep, then optimize the disk.**

For example, if six takes exist on the disk, as shown below, and you wish to keep only Take 4, apply the Multiple Undo function to Take 4. As shown on the second time axis, Take 4 moves up to the most recent position. Now, if you optimize the disk, all takes but Take 4 will be erased.

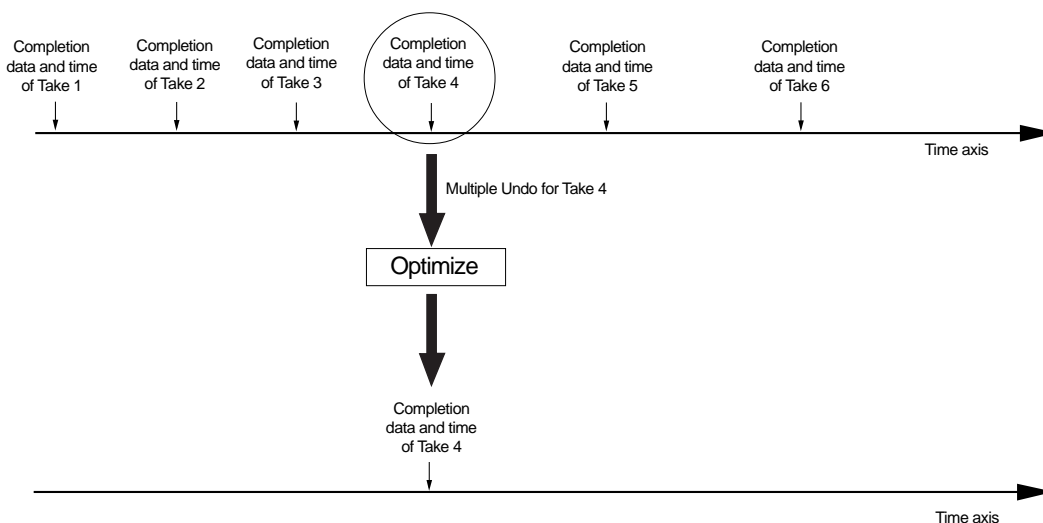
**<Keeping multiple takes>**

*** Apply the Multiple Undo to the desired takes and copy the Program.**

For example, if you wish to keep Take 2 and Take 4, follow the procedure described above to apply the Multiple Undo function to Take 2, then create a copy of the Program. (The Program copy will have only Take 2 available for the Multiple Undo function.) In the same way, apply the Multiple Undo function to Take 4 this time, then create another copy of the Program. In this way, you can create copies of the Programs that contain the desired takes.

Editing Tracks

The recorder features speedy, nonlinear, nondestructive editing of independent audio tracks because it uses a 3.5 inch E-IDE hard disk. The following four editing functions allow “Editing of Independent Audio Tracks.”

Copy & Paste

You can copy a specific range of data from a specific track and paste it to the same or a different track. Copy & Paste is possible in the presently active program or also in a different program.

Move & Paste

You can move a specific range of data from a specific track and paste it to the same or a different track.

Move & Paste

You can erase a specific range of data from a specific track or all tracks.

Track Exchange

You can swap data between tracks. Monaural track data can be swapped between Real tracks 1-8 and Additional tracks 9-24. Multiple-track data can be swapped between Real tracks 1-8 and Additional tracks 9-16, and Additional tracks 17-24 by eight-track unit.

<Note>

Although Copy & Paste can be executed in a different program, all other editing work can only be done within the currently active program. Consequently, in order to edit the active program, the desired program should be selected before starting to edit. In general, don't change a program until you finish editing except to Copy & Paste to a different program.

If editing is started while in another program, you could accidentally lose data.

Copy & Paste, Move & Paste, and Erase with the exception of track exchange, is possible only for data recorded on the real track. If data stored in the additional track is to be edited, move it temporarily to a real track, and then edit it.

Copy & Paste and Move & Paste

Copy & Paste and Move & Paste might seem like the same function. However, they are different, as shown in the diagram. Remember this difference when you start using these functions.

• Copy & Paste

Using the Copy & Paste function enables you to copy a specific range of data from a specific track to the clipboard as shown below (this is called [Copy Clip] operation on the unit), then paste the data at a specific point in a specific track. The number of copy source tracks and the number of destination tracks are the same. That is, if you copy mono track data, you can paste it to a mono track. If you copy adjacent odd/even tracks (e.g., track 1 and track 2), you can paste it to adjacent odd/even tracks. After paste is executed, data on the clipboard will remain intact and as can be repeatedly pasted, as well as to other programs.

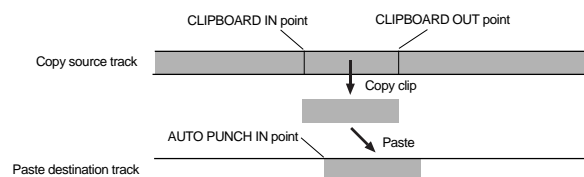

• Move & Paste

Move & Paste is almost the same as Copy & Paste. As shown in the figure, it allows you to move a specific range of data from a specific track to the clipboard (this is called [Move Clip] on the unit), and paste it to a destination track. The difference from Copy & Paste is that the data on the source track and the clipboard will be erased when you paste the data to the destination. That is, you cannot paste the moved data repeatedly. Unlike Copy & Paste, this cannot be executed between programs.

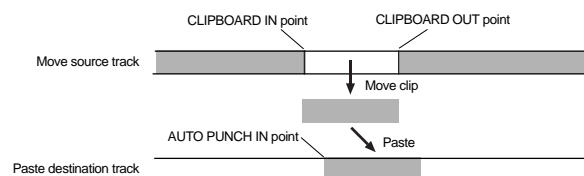

As shown in the drawing, points for copy or move are called the CLIPBOARD IN point for the copy (or move) starting point, and CLIPBOARD OUT point for the ending point, and the paste starting point is called the AUTO PUNCH IN point.

<Notes>

- * The data on the clipboard will be replaced by new data each time you execute the COPY or MOVE.
- * If pasted data overlaps the source data, the content of the source data will be altered.

Perform Copy & Paste and Move & Paste in the following order.

The explanation here is on Copy & Paste or Move & Paste methods in the currently active program. For Copy & Paste between programs, read page 69.

1. Store the copy (or move) start point (CLIPBOARD IN point), end point (CLIPBOARD OUT point), and the paste start point (AUTO PUNCH IN point).
2. Check the stored edit points using the Preview function and make adjustments if necessary.
3. Specify the copy (or move) source track, and copy (or move) the data to the clipboard.
4. Specify the destination track and the number of times for the paste operation (repeated paste), and execute the paste operation.

Storing the edit points

1. Refer to the “Storing and editing the locate points to the memory keys” section for information on storing the copy (or move) start and end points, and the paste start point.

Store the copy (or move) start point to the CLIPBOARD IN key, the end point to the CLIPBOARD OUT key, and store the paste start point to the AUTO PUNCH IN key.

- See “Storing and editing the locate points to the memory keys” on page “54.”

Checking and adjusting the edit points

After you store the edit points, you can check them on the display by pressing the corresponding keys. You may also adjust the points. This section explains how to preview and fine-tune the edit points using the Preview function.

1. While the recorder section is stopped, press and hold down the SHIFT key and press the memory key for which you wish to check the edit point.

You can preview “fade in” at the CLIPBOARD IN point, “fade out” at the CLIPBOARD OUT point, and “fade out” at AUTO PUNCH IN point.

2. Trim the edit point while previewing.

- Refer to “Preview Function” on page “63” for more information.

Executing Copy (or Move)

1. Press the RECORD TRACK select key of the copy (or move) source track to set it READY.

Select from mono tracks or adjacent odd-even tracks (1-2, 3-4, 5-6 etc.).

<Note>

If you select non-adjacent tracks, such as track 1 and 3, or tracks 1 and 4, the copied (or moved) data will be pasted back to the copy (or move) source tracks.

2. Press the EDIT key repeatedly until [Copy Clip?] (or [Move Clip?]) flashes on the display.

Select [Copy Clip?] to execute Copy & Paste. Select [Move Clip?] to execute Move & Paste.

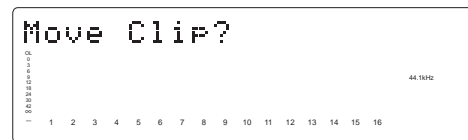
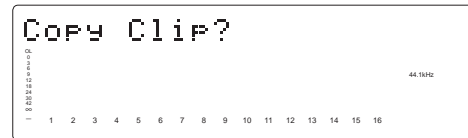

3. Press the EXECUTE/YES key.

The copy (or move) operation will complete immediately. The display briefly indicates [COMPLETED !], then flashes the [Copy Paste ?] (or [Move Paste ?]) message. The recorder enters standby mode for the paste operation. The indicates (small square) of the selected RECORD TRACK select keys continue to flash.

<Notes>

- * Pressing the EXECUTE/YES key without selecting track in Step 1 will cause the display to indicate an alarm message [Select TRK !]. Select a track, then press the EXECUTE/YES key.
- * If an Output point has been specified before the In point (the In point value is the same or large than the Out point value), the display will show the error message “Void In Point!” or “Void Out Point!” and the return to the previous screen. In this case, set the correct In/Out points and try again to copy (or move) the data.

Now the sound data to be pasted has been copied (or moved) to the clipboard, you can check the data on the clipboard by following the steps below. If there is no problem with the data, you can proceed to the paste operation.

Checking the clipboard data

- * Hold down the STOP button and press the PLAY button.

The recorder indicates whether the sound data on the clipboard is a copied data or moved data ([Copy Clip] or [Move Clip]) and plays the data (this is called “clipboard playback”). Monitor the playback sound through the mixer channels that correspond to the copied (or moved) tracks. During clipboard playback, the indicates of the RECORD TRACK select key for the copied (or moved) track will flash.

- * Press the EDIT key again to get ready for the paste operation.
[Copy Paste?] or [Move Paste?] flashes on the display.

Executing Paste

4. Press the EXECUTE/YES key again.

The display indication enables you set the number of the paste operations. The number and [SURE?] flash. At this time, the flashing RECORD TRACK indicator becomes continuously lit.

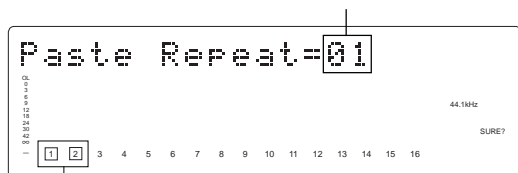

Track display (□) of the item to be copied (or moved) will change to lit.

5. Select a destination track to paste data.

All selected track's indicator light up. You can select only mono tracks as the destination of a copied or moved mono track. If you copied or moved adjacent odd-even tracks, you can select only adjacent odd-even tracks as the destination. If you do not select any tracks, the data will be pasted back to the copy or move source track.

6. Turn the JOG dial to enter the number of repeats (Repeat = **).

You can enter up to 99. However, this is automatically limited by the available recording source on the disk. That is, if the disk has enough free space, you can set up to 99 repeats. If the disk has only a small amount of free space, the JOG dial allows you to set a lower number of repeats.

7. Press the EXECUTE/YES key.

[Copy P.] (or [Move P.]) flashes and the duration of the pasted data appears as a negative number on the display. This number will count down as the paste operation proceeds. When the paste operation is complete, the flashing [Copy P.] (or [Move P.]) lights up continuously, and [COMPLETED !] is displayed.

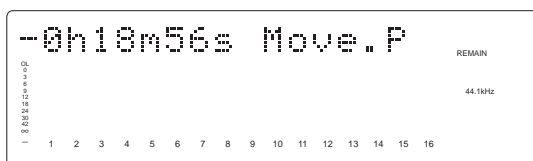
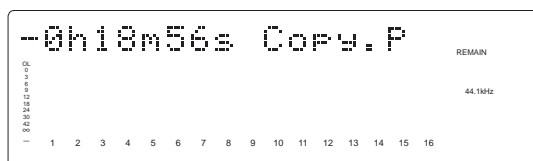

<Note>

If you try to execute the paste operation by pressing the EXECUTE/YES key when the disk has insufficient free space, [Over !] appears on the display and edit mode is cancelled.

In this case, you need to delete unnecessary data or programs.

- * Refer to the following section, "Erase," "Deleting a Program," or "Duplicating a Program."
- * Refer to page "70" for more information on erasing.
- * Refer to page "36" for more information on deleting a program.
- * Refer to page "35" for more information on duplicating a program.

8. Press the EXIT/NO key or the STOP button.

The recorder exits edit mode and displays the previous Time Base indication.

9. Turn off the RECORD TRACK select key of the copy (or move) source track.

Single Undo/Redo Paste

You can single undo or redo a Copy & Paste and Move & Paste operation.

- To restore the data that existed prior to the paste operation, press the UNDO/REDO key.

- To restore the pasted data after you undo the paste operation, press the UNDO/REDO key again.

When you press the UNDO/REDO key, the recorder will undo or redo the operation immediately, and display [Undo !] or [Redo !] and [COMPLETED !].

<Note>

This function only works when this recorder is in the stop mode.

<Note>

If you perform one of the following operations after you use the Copy & Paste or Move and Paste operation, the Undo/Redo function will no longer be effective.

1. If a new recording has been made.
2. When a new editing job is executed (such as Copy & Paste, Move & Paste, Erase).
3. While in the AUTO PUNCH ON mode, when the AUTO PUNCH IN point is passed in the PLAY (or RECORD) mode.
4. If the power was switched off.
5. If program select was executed.
6. When multiple undo is executed.

Copy & Paste between programs

Copy & Paste between programs can be performed using the procedures below in the same manner as in the previous “Copy & Paste in the same program.”

1. Store the copy (or move) start point (CLIPBOARD IN point), end point (CLIPBOARD OUT point), and the paste start point (AUTO PUNCH IN point).
2. Check the stored edit points using the Preview function and make adjustments if necessary.
3. Specify the track to be copied and copy it in the clipboard (Copy Clip).
4. Switch to program for pasting using the program select function.
5. Register the copy starting point (AUTO PUNCH IN point) in the switched program.
6. Check the registered editing point with the “Preview function” and if necessary, correct the editing point.
7. In the same way as before, enter the editing mode by pressing the EDIT key. [Copy Paste?] will be displayed after pressing the EDIT key.
8. Next, specify the track and amount to be pasted and execute paste.

Checking the clipboard data

Data copied to the clipboard can be confirmed even after switching the program by the above procedure. For example, when a specific data in Program 1 is copied to the clipboard and then switched to Program 2 in which it is to be pasted, as mentioned before, if the PLAY button is pressed while pressing on the STOP button, you can listen to data copied in Program 1 (clipboard play).

During clipboard play, [P01] will appear in the display to indicate that copy data in Program 1 is being played back.

Erase

There are two methods for erasing data. Understand the difference between these methods before you use the Erase function.

** If multiple Programs are set on the disk, first select the desired Program. Do not select another Program, or select another sampling rate until you finish the erase operation.*

• Erasing a specified part of the data between ABS 0 and REC END:

You may erase a specified part of the data between ABS 0 and REC END (the end point of the recording) in the currently-selected Program. (The erased part is replaced with silence.) You can erase data on a mono real track or multiple real tracks. To erase data on an additional track, you need to move the data to a real track, then erase it. As shown below, the REC END point (the end point of recording) is not affected. The erased area is replaced with silence. As a result, the REMAIN time and space will increase. (You will have more recordable space on the disk.)

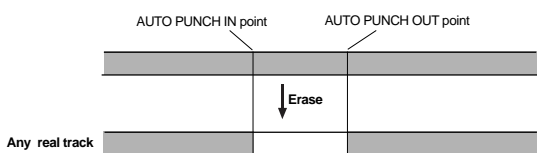

• Erasing data from a specified point to REC END:

You may erase all data in the range from a specified point to REC END in the currently-selected Program. You can erase data on a mono real track or multiple real tracks. To erase data on an additional track, you need to move the data to a real track, then erase it. When you erase all tracks' data, the REC END point will move backward. However, if you erase data on a mono track or multiple tracks (but not all tracks), the REC END point may not be affected. (Refer to the note below.) After the erase operation, the REMAIN time and space will increase.

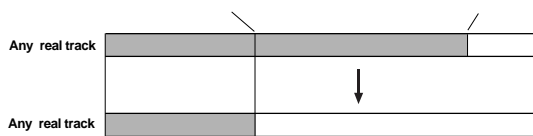

<Note>

If all real tracks contain data as shown below, erasing data on tracks 1 and 2 will not affect the position of REC END. On the other hand, if all Real tracks contain data as shown below, erasing data on tracks 3 - 8 will move up REC END to the end point of tracks 1 and 2.

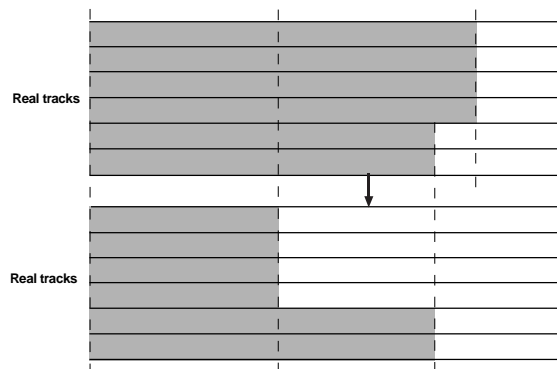
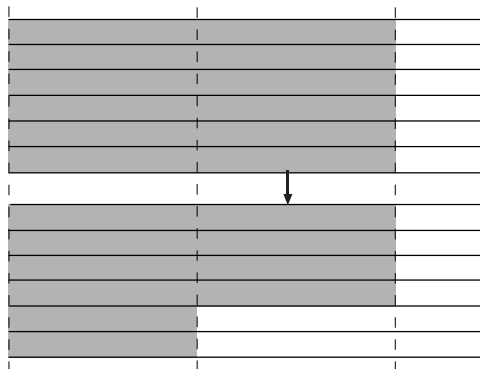

Follow the steps below to erase data:

1. Store the erase start point (AUTO PUNCH IN point) and the erase end point (AUTO PUNCH OUT point).
2. Use the Preview function to check the stored edit points and adjust them if necessary.
3. Specify a track to erase and execute the function.

Storing the edit points

1. Refer to the "Storing and editing the locate points to the memory keys" section for information on storing the erase start and end points.

Store the erase start point to the AUTO PUNCH IN key, and the end point to the AUTO PUNCH OUT key.

- If you wish to erase the data from a specific point, store the REC END or later point as the erase end point. Refer to the <Note> for information on storing the REC END point.
- See "Storing and editing the locate points to the memory keys" on page "54".

Checking and adjusting the edit points

After you store the edit points, you can check them on the display by pressing the corresponding keys. You may also adjust the points.

1. While the recorder section is stopped, press and hold down the SHIFT key and press the memory key for which you wish to check the edit point.

You can preview “fade-out” at the AUTO PUNCH IN point and “fade-in” at AUTO PUNCH OUT point.

2. Trim the edit point while previewing.

- Refer to “Preview Function” on page “63” for more information.

Executing Erase

1. Press the RECORD TRACK select key to select the track to erase, to set it READY.

You can select a mono track or multiple tracks (including all tracks). The selected track indication flashes.

2. Press the EDIT key repeatedly until [Erase] flashes on the display.

3. Press the EXECUTE/YES key.

The flashing [Erase] message lights up steadily, and [SURE?] flashes.

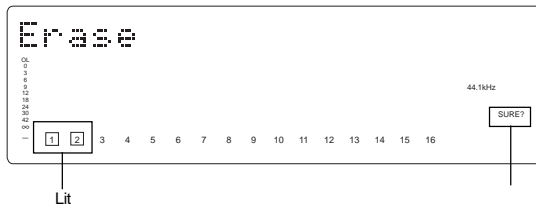

- To cancel the erase operation, press the STOP button or the EXIT/NO key while [SURE ?] flashes on the display.

4. Press the EXECUTE/YES key again.

The recorder starts erasing the data and [Wait Erasing!] flashes. When the erase operation is completed, [COMPLETED !] lights up.

5. Press the STOP button or the EXIT/NO key.

The recorder exits edit mode and displays the previous Time Base indication.

<Check Points!>

- To erase the data in its entirety from the tracks, you can also use the Program Delete function to erase the entire Program. In either case, you can expand the recordable area on the disk. Use either one of the erase operations to erase unnecessary data if the recorder displays an alarm message indicating insufficient recordable space for Auto Punch In/Out, Copy & Paste, or Move & Paste.
- To erase the data in its entirety from ABS 0 - REC END, it is recommended that erase end point (AUTO PUNCH OUT point) is stored after the REC END time to ensure through erase performance. To do this, move the recorder section location to the REC END point prior to storing the AUTO PUNCH OUT point, press the PLAY button from that location, move the ABS time after the REC END, and store. The hard disk will not successfully access points after REC END though play is executed after REC END, however, this makes it possible to move up the ABS time.

Single Undo/Redo Erase

You can single undo or redo the Erase operation.

- To restore the data that existed before you erased it, press the UNDO/REDO key.
- To restore the data after you undo the Erase operation, press the UNDO/REDO key again.

When you press the UNDO/REDO key, the recorder will undo or redo the operation immediately, and display [Undo !] or [Redo !] and [COMPLETED !].

<Note>

This function only works when this recorder is in the stop mode.

<Note>

If you perform one of the following operations after you use the Copy & Paste or Move and Paste operation, the Undo/Redo function will no longer be effective.

1. If a new recording has been made.
2. When a new editing job is executed (such as Copy & Paste, Move & Paste, Erase).
3. While in the AUTO PUNCH ON mode, when the AUTO PUNCH IN point is passed in the PLAY (or RECORD) mode.
4. If the power was switched off.
5. If program select was executed.
6. When multiple undo is executed.

Track Exchange

The Track Exchange function enables you to swap mono track data or multiple track data of the current Program between Real tracks and Additional tracks in units of single or multiple tracks. You can swap mono track data between Real tracks, Additional tracks, or between a Real track and an Additional track. You can swap multiple track data between eight Real tracks (1-8) and Additional tracks (9-16 or 17-24). Refer to the diagrams below for information on how data on the tracks can be moved using this function.

The Track Exchange function also enables you to move Real track data to an empty Additional track (to empty the original Real track) so that you can use the Real track for a new recording. This capability lets you use tracks more flexibly.

You need to move data on an Additional track back to a Real track to audition the data, since data on an Additional track cannot be played in real-time.

You can also use this function when you wish to check the REC END point of an Additional track, as described in the "Erase" section. Execute [Track Exchange] with the [Track Exchange?] menu in the SETUP mode of the recorder.

Swapping mono track data between Real tracks, Additional tracks, or between a Real track and an Additional track.	Swapping multiple track data between eight Real tracks and eight Additional tracks (9-16 or 17-24).
D824 and D1624 formatted in 96kHz/24bit	
D1624 formatted in other than 96kHz/24bit	

Executing Track Exchange

1. While the recorder is stopped, press the EDIT key.
2. With the JOG dial, choose "[Track Exchange?]" menu.

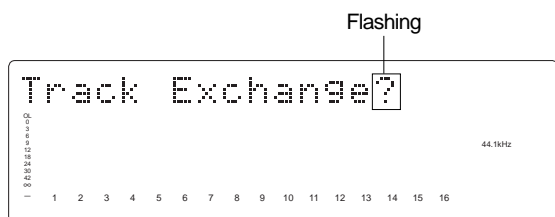

3. Press the EXECUTE/YES key.

The display shows the track selection. The current display shows that you can swap eight-track data between Real tracks 1-8 and Additional tracks 9-16. If you wish to select other tracks, follow the step below.

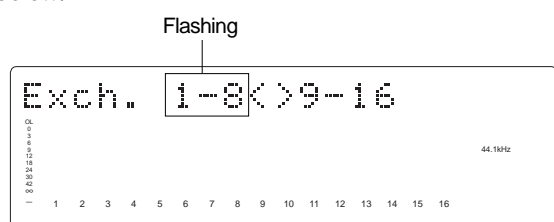

4. Select the tracks to swap data.

- Selecting Real tracks 1-8 and Additional tracks 17-24:

1. Turn the SHUTTLE dial to move the flashing [1-8] (left) indication to the flashing [9-16] (right) indication.

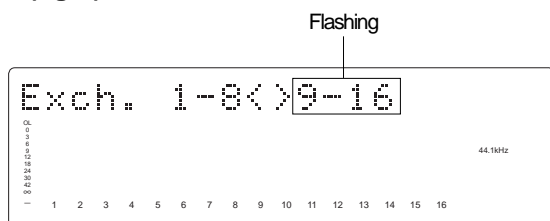

2. Turn the JOG dial to change flashing [9-16] to flashing [17-24].

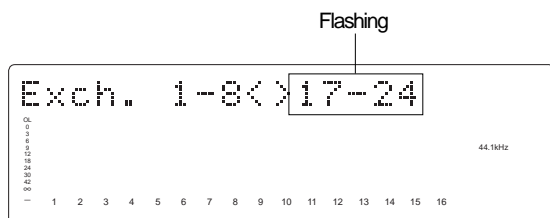

- Swapping mono track data between any two tracks

1. When [1-8] is flashing, turn the JOG dial.

Turning the JOG dial allows you to select a mono track from [1], [2], [3], [4]..... [24] in the left column. The right column continues a mono track.

For example, if you select [4] in the left column, the display indicates [4<>1], meaning you can swap data between tracks 4 and 1.

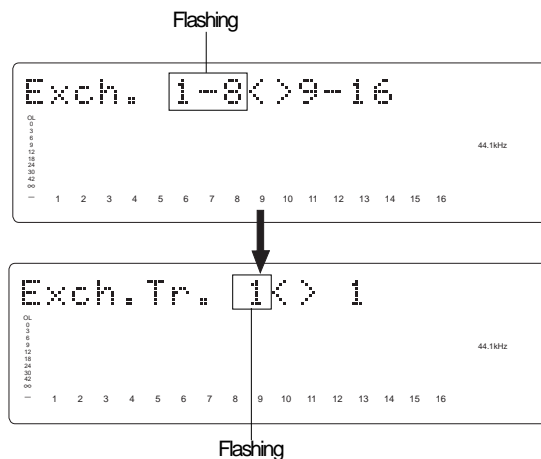

2. To select a number on the right, turn the SHUTTLE dial as done for the left, to move the flashing point. Then use the JOG dial to select a specific track number.

* When you swap data between mono tracks, the indications [Trk=04<->Trk=01] and [Trk=01<->Trk=04], for example, mean the same thing — swapping data between tracks 1 and 4.

<Note>

If you select the same tracks for swapping mono track data, the setting is ignored. The recorder will indicate [Select Err] for a short moment, then return to the previous display.

4. Press the EXECUTE/YES key.

[Exchange] lights up and the swapping operation is completed immediately.

The recorder indicates [COMPLETED !], then returns to the previous Time Base display.

* You cannot play data or check the REC END point on the Additional tracks. To do so, you need to move the data to a Real track.

If you load back-up data from the external DAT recorder, adat machine, or backup SCSI drive, the data maintains the same condition as when you previously saved it to DAT, adat, or backup SCSI drive.

MIDI Sync Function

The following are examples concerning general types of systems using MIDI related functions contained in the recorder.

MIDI clock sync system

By setting any desired meter at any desired point of the programmable tempo map contained in the recorder, and by output of a MIDI clock and song position pointer according to the setting, a hardware type MIDI sequencer can be synchronized as a MIDI clock slave. Consequently, in this system, the recorder will be the master and the MIDI sequencer the slave.

* Restore the default settings on this recorder.
 * Check for the correct program and proper sampling frequency.

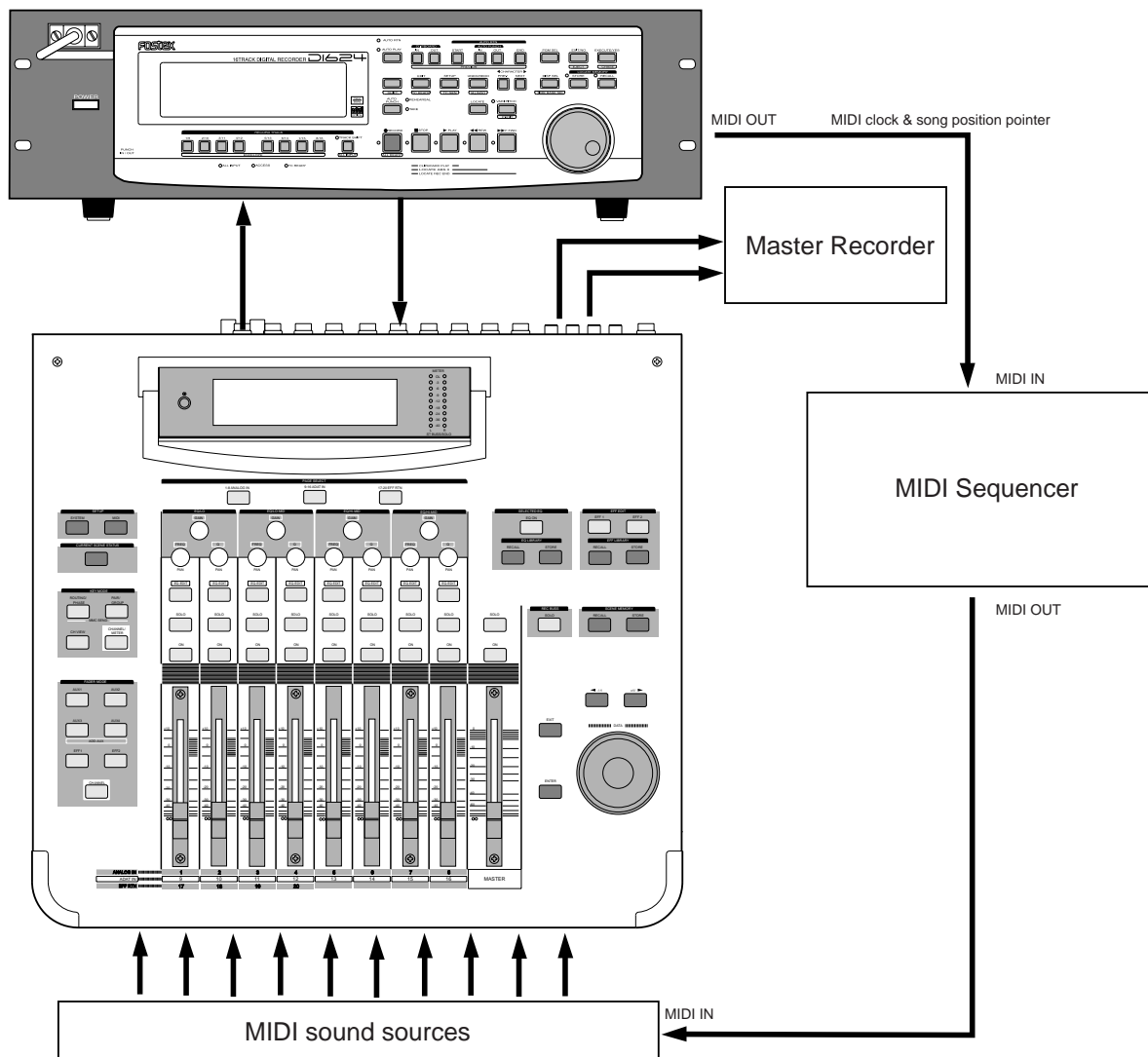

Connecting external equipment (Refer to connecting schematic)

1. Connect the unit MIDI OUT to MIDI IN of the MIDI sequencer.
2. Set the MIDI sequencer for "external sync mode (EXTERNAL SYNC) by MIDI clock."

* Refer to the Owners Manual of the equipment in use for details.

Setup of the recorder

1. Because the MIDI clock and song position pointer will be output from the recorder, set the SETUP mode "MIDI sync signal output setting" to "CLK."

* Initial setting:	MTC
* Permissible setting:	CLK (MIDI clock and song position pointer:"CLK") MTC (MIDI time code: "MTC") Off (No output of MIDI sync signal)
* This item can be setup for each program.	
* The setting can be saved/loaded as song data.	
* This setting will be held even though power is switched OFF.	

Refer to page "109", SETUP mode "MIDI sync signal output setting" for correct operating procedures.

2. The meter in the desired bar can be set by "Time signature setting" of the SETUP mode.

* Initial setting:	001 bar, 4/4 signature.
* Permissible bar setting:	001~999
* Permissible meter setting:	1/4, 2/4, 3/4, 4/4, 5/4, 1/8, 3/8, 5/8, 6/8, 7/8, 8/8, — — (Elimination of signature)
* Permissible setting of maximum number of points: 64 points	
* This item can be set for each program.	
* The setting can be saved/loaded as song data.	
* This setting will be held even though power is switched OFF.	

Refer to page "103", SETUP mode "Time Signature Setting" for operating procedure.

3. Tempo in the desired bar can be set by "Tempo setting" of the SETUP mode.

Tempo map is made in steps 2 and 3.

* Initial setting:	001 bar, 1st meter, Tempo120.
* Permissible bar setting:	Follows the previous "Setup of the time signature."
* Permissible signature setting:	Follows the previous "Setup of the time signature."
* Permissible setting of tempo:	Quarter note=30~250 (Tempo elimination)
* Permissible setting of maximum number of points: 64 points	
* This item can be set for each program.	
* The setting can be saved/loaded as song data.	
* This setting will be held even though power is switched OFF.	

Refer to page "105", SETUP mode "Tempo Setting" for operating procedure.

4. Set the SETUP mode "Metronome setting" to ON if click sound is to be output according to the setup tempo map.

* Initial setting:	Off
* Permissible setup item:	Off, On
* This item can be set for each program.	
* The setting can be saved/loaded as song data.	
* This setting will be held even though power is switched OFF.	

Refer to page "107", SETUP mode "Metronome setting" for operating procedure.

5. Press the DISP SEL key while holding down the SHIFT key, and then change the time base display to BAR/BEAT/CLK.

Confirming the MIDI clock sync

During recording and at playback following the recording, the time base (BAR/BEAT/CLK) is displayed in accordance to the setup tempo map, and the MIDI clock and song position pointer is also output.

Confirm that the travel position (BAR/BEAT/CLK) of the recorder and the travel position of the synchronized MIDI sequencer are matched.

* If correct sync cannot be obtained, re-check the connections/cables and setting of both equipment.

<Note>

In the recorder, the "ABS 0" position is set at "002BAR/1BEAT /00CLK."
 This setting is made in consideration of the time required (it will not sync immediately) for the MIDI sequencer, etc. to enter into sync. As a result, if the recorder is played back from ABS 0 (LOCATE ABS 0), sync will be completed by the time it reaches the first bar, and will thus synchronize from head of the tune.

Execution of recording

Various ways of recording can be conducted while synchronizing the recorder and the MIDI sequencer with the MIDI clock.

MTC sync/MIDI machine control system

The following will explain synchronization by the MTC (MIDI time code) output and the computer controlling system using MMC (MIDI machine control). In this system, the recorder will be the master and the computer (with sequence software) will be the slave. The recorder will attach any desired offset (time difference) against ABS time (absolute time) and output it as MTC in any desired frame rate. It can also carry out the proper operation upon receiving an MMC and Fostex System Exclusive Message from outside. In this case, because the recorder can setup a DEVICE ID number by the SETUP mode "MIDI Device ID Setting" menu, a multiple number of the unit's can be separately controlled by changing the DEVICE ID numbers in the transmitted message from the computer. In regards to the corresponding content for MMC, refer to the "MMC list" on page "123" and on the Fostex System Exclusive Message, the "Fostex Exclusive List" on page "124."

- * Set the recorder in the initial state.
- * Confirm the program and sampling frequency.

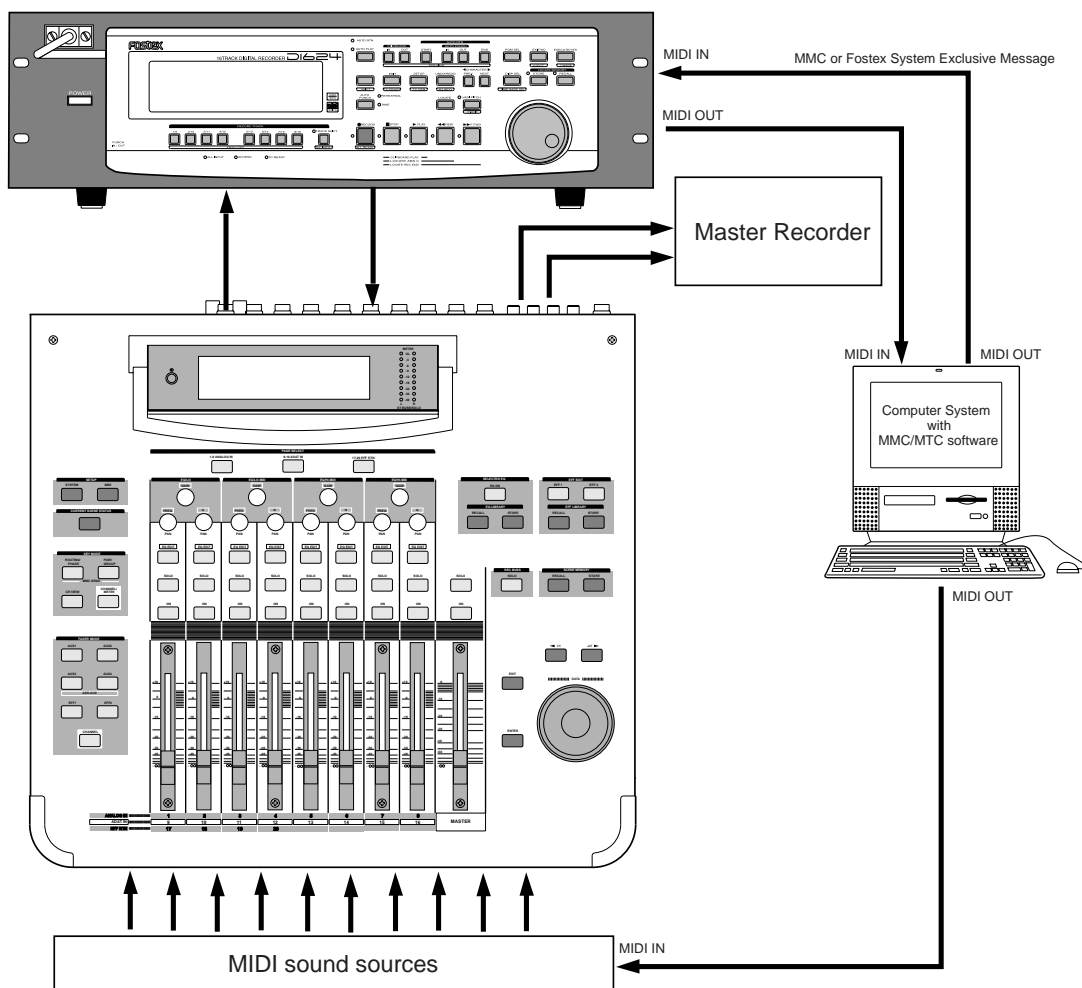

Connecting to external equipment

Connect the recorder MIDI IN/OUT to the computer (with MIDI interface) MIDI IN/OUT (MMC/MTC complied sequence software is activated in the computer).

Setup of external equipment

Setup the following in the sequence software.

- * Set to MTC external sync mode (EXTERNAL SYNC).
- * Set for output of MMC.
- * Set to the desired MTC read out frame rate.
- * Set start time of the tune (which MTC time is to be the first bar). Refer to precaution in regards to MTC offset, farther on.

For details, refer to Owners Manual of the external equipment.

Setup of the recorder

1. Because MTC will be output from the recorder, set to “MTC” the SETUP mode “MIDI sync signal output setting.”

Refer to page “109”, SETUP mode “MIDI sync signal output setting” for operating procedure.

2. Set a random offset time by the SETUP mode “MTC offset time setting.”

- * Initial setting: **00h (Hour) 59m (Minute) 57s (Second) 00f (Frame) 00sf (Sub Frame)**
- * Permissible setup time: **00h 00m 00s 00f 00sf ~ 23h 59m 59s 29f 99sf**
- * This item can be set for each program.
- * The setting can be saved/loaded as song data.
- * This setting will be held even though power is switched OFF.

Refer to page “110”, SETUP mode “MTC offset time setting” for operating procedure.

3. In the SETUP mode “MTC offset mode setting,” whether the MTC offset time setup in Step 2 should be output (ABS) at the ABS 00m 00s 00f 00sf position or at the 001BAR 1BEAT 00CLK (bar, signature) must be selected.

- * Initial setting: **ABS**
- * Permissible setup item: **ABS, Bar Beat**
- * This item can be setup for each program.
- * The setting can be saved/loaded as song data.
- * This setting will be held even though power is switched OFF.

Refer to page “111”, SETUP mode “MTC offset mode setting” for operating procedure.

4. Setup to the same frame rate as that setup by the sequence software by “MTC Frame rate setting” of the SETUP mode.

- * Initial setting: **25 frames**
- * Permissible setup of frame rate: **24, 25, 29.97nd, 29.97df, 30nd, 30df**
- * This item can be setup for each program.
- * The setting can be saved/loaded as song data.
- * This setting will be held even though power is switched OFF.

Refer to page “109”, SETUP mode “MTC Frame rate setting” for operating procedure and details.

5. Set to the same figure as the sequence software MMC device number (and Fostex System Exclusive Message device number) by the SETUP mode “MIDI device ID setting.”
When the sequence software transmits by “7F,” it means “ALL DEVICE” and therefore, it need not be setup.

- * Initial setting: **00**
- * Permissible setup ID: **00 ~ 99**
- * This item will be the setting common to all programs.
- * This setting cannot be saved/loaded as song data.
- * This setting will be held even though power is switched OFF.

Refer to page "116", SETUP mode "MIDI device ID setting" for operating procedure and details.

6. Press the DISP SEL key while holding down the SHIFT key to show time base in the MTC display.

<Notes on MTC related setups>

By "MTC offset time setting" and "MTC offset mode setting," at what position (ABS 0 or 001BAR/1BEAT/00CLK) should the setup MTC (MTC offset time) is to be output is set. When setting the start time of the tune in the sequence software by these setups, be careful of the following points.

*** Offset mode: For ABS**

If playback is started from ABS 0, since MTC will be output starting from the MTC offset time that has been set, the start time of the tune set by the sequence software must be set about 3 seconds later from the MTC offset time that was setup. This will provide time because the sequence software cannot sync immediately after MTC is output. For example, if the initial setting of 00h 59m 57s 00f 00sf" is used, set the start time of the tune to "01h 00m 00s 00f." If playback is thus started from ABS 0 (LOCATE ABS 0), sync will be obtained by the time it reaches the first bar and therefore it can be made to sync from the head of the tune.

*** Offset mode: For BAR**

As mentioned before, because the "ABS 0" position is set at the "002BAR / 1BEAT / 00CLK" position, the setup MTC offset time can be set to the head of the tune without taking into account the time until reaching sync, as mentioned above. The length of the time two bars beforehand will change in accordance to the first bar setting for "signature" and "tempo." For example, it will be long if the tempo is set slow. This mode can be effectively applied when using the MIDI clock and MTC in parallel, and when using MTC for the sync signal while controlling the recorder with time base BAR/BEAT/CLK.

Confirming MTC sync/MMC

1. During recording and at playback after recording, time base MTC is displayed according to the setting and MTC is output at the same time.

Check that the recorder traveling position (MTC) and the traveling position of the sequence software in sync are matched.

2. Send MMC commands such as PLAY, STOP and LOCATE from the sequence software to see that the recorder will be properly controlled.

When a correct MIDI command (MMC or FEX) is received, "MIDI" in the display will be lit for about 40msec. There is no setting in the recorder to receive MMC or FEX but it will operate if a correct MIDI signal is input.

* If sync and control cannot be done correctly, re-check connections/cables and the setting of both equipment.

Execution of recording

Carry out various recordings while synchronizing the recorder and a MIDI sequencer with the MIDI clock.

Multitrack system by the slave mode

An example of how to make a multitrack system by interconnecting three recorders in a slave mode function, will be explained in the following.

A 24 multitrack system can be designed if a D824 is used for this system; if D1624 is used, a 48 multitrack system can be made.

- * Initialize the recorder.
- * Confirm the program.
- * Set all three recorder's to the same sampling frequency.

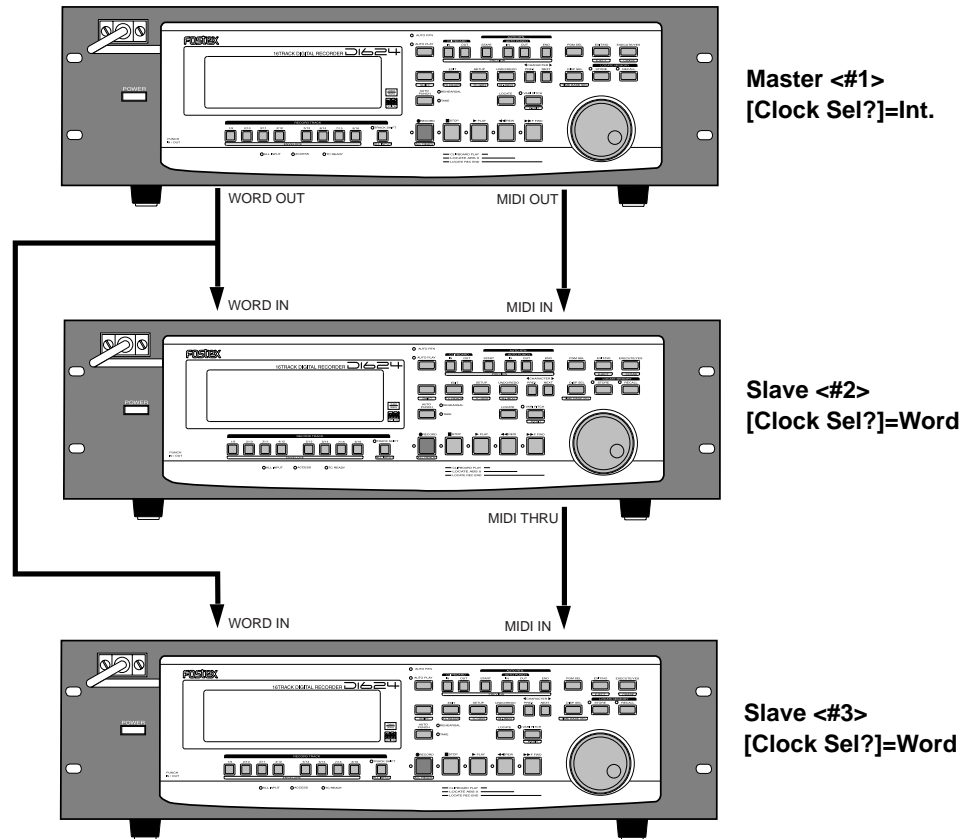

Equipment interconnections

1. From the recorder (#1) to the recorder (#2), connect WORD OUT to WORD IN and MIDI OUT to MIDI IN.
2. From the recorder (#1) to the recorder (#3), connect WORD OUT to WORD IN.
3. From the recorder (#2) to the recorder (#3), connect MIDI THRU (Note!!!) to MIDI IN.

<Notes>

- * In order to slave drive the recorder with each other, the best setting is to supply word clock signals together with MTC from the master.
- * As shown in the above schematic, at input or the Word Clock from the master to the second slave, WORD OUT from the master must always be branched to the second slave. Do not connect the first slave WORD OUT to the second slave WORD IN.

Setup of the recorder (#1): <Master>

1. Because MTC, which is the reference for sync, is output from the recorder (#1), set the "MIDI sync signal output setting" of the SETUP mode to "MTC."

Refer to page "109", SETUP mode "MIDI sync signal output setting" for operating procedure and details.

2. A random frame rate to be used is set by the SETUP mode "MTC Frame rate setting."

Refer to page "109", SETUP mode "MTC Frame rate setting" for operating procedure and details.

3. With the SETUP mode “MTC offset mode setting,” whether the MTC offset time will be output (ABS) at the ABS 00h 00s 00f 00sf point or at the 001BAR 1BEAT 00CLK (bar/signature) point of the tempo map, is selected.

Refer to page “111”, SETUP mode “MTC offset mode setting” for operating procedure and details.

4. A random offset time is set by the SETUP mode “MTC offset time setting.”

Refer to page “110”, SETUP mode “MTC offset time setting” for operating procedure and details.

5. “00” is set with the SETUP mode “MIDI device ID setting.”

Refer to page “116”, SETUP mode “MIDI device ID setting” for operating procedure and details.

6. Set to “Int.” the clock setting by the SETUP mode “Clock setting.”

Refer to page “117”, SETUP mode “Clock setting” for operating procedure and details.

7. Press the DISP SEL key while holding down the SHIFT key to change the time base display to MTC.

Setup of the recorder (#2) <Slave 1> and (#3) <Slave 2>

1. Set the SETUP mode “MTC Frame rate setting” to the same frame rate as in the recorder (#1).

Refer to page “109”, SETUP mode “MTC Frame rate setting” for operating procedure and details.

2. Set the SETUP mode “MTC offset mode setting” to the same mode as in the recorder (#1).

Refer to page “111”, SETUP mode “MTC offset mode setting” for operating procedure and details.

3. Set the SETUP mode “MTC offset time setting” to the same offset time as in the recorder (#1).

Refer to page “110”, SETUP mode “MTC offset time setting” for operating procedure and details.

4. Set the SETUP mode “MIDI device ID setting,” to “01” in the recorder (#2), and to “02” in the recorder (#3).

Refer to page “116”, SETUP mode “MIDI device ID setting” for operating procedure and details.

5. Press the EXECUTE/YES key While holding down the SHIFT key, set slave mode to “On.”
[CHASE] indicator will be flashing in the display.

6. Using the SETUP mode “Slave type setting,” set slave type to “Free.”

* Slave type initial setting: Vari
* Permissible setup item: Vari, Free
* This item can be set for each program.
* The setting can be saved/loaded as song data.
* This setting will be held even though power is switched OFF.

Refer to page “112”, SETUP mode “Slave type setting”, for operating procedure and details.

7. Set to “Word” the clock setting by the SETUP mode “Clock setting.”

Refer to page “117”, SETUP mode “Clock setting” for operating procedure and details.

8. Press the DISP SEL key while holding down the SHIFT key, to change the time base display to MTC.

<Note>

After this setup, check the following in the recorder (#2) and (#3).

* *Blinking of "CHASE" in the display: This will change to constant lit upon completing chase lock in later operation.*

* *"EXT SYNC" is lit in the display: This means it is externally synchronized against the input word clock signal.*

Check chase lock

- 1. When the master recorder (#1) is played back, MTC IN LED of the slave recorder (#2) and (#3) will be lit, "CHASE" in the display will immediately change from blinking to lit and chase lock will be completed.**
Check that the MTC time on display are same in both master and slave units.
- 2. When the master starts recording, the slave will also start recording upon completing chase lock.**
- 3. When the master is stopped, the slave will also stop as MTC from the master will be interrupted.**
"CHASE" in the display will change from lit to blinking.
- 4. During FF/REW, the master only will be in the FF/REW mode and the slaves will remain stopped but when playback/recording is started, the slaves will immediately chase lock.**

<Note>

The unit re-chase window is fixed at "10 frame." In other words, when MTC of the master and slave drifts apart more than 10 frames, it will assume that chase lock is disengaged and the slave will match the position again with the master (re-chase operation). During the re-chase operation, sound output will be muted. If the drift is within 10 frames, the slave will recognize this and continue to travel. Because the master supplies digital signal to slave in this system, re-chase is rarely carried out following chase lock.

* Should the unit fail to correctly chase lock and control, re-check the connection /cables and all settings.

Selecting a record track

A variety of recording work can be carried out with all three recorder's in the chase lock mode.

Execution of recording

A variety of recording work can be carried out with all three recorder's in the chase lock mode.

External MIDI equipment sync system by the slave mode

Up to this point, synchronization with external MIDI equipment has been explained with the recorder as the master and MIDI equipment as the slave but depending on the slave mode setting, the MIDI equipment can be set as the master and the recorder as the slave.

<Note>

External MIDI equipment which can be used as the master is limited to those which can output MTC.

- * Initialize the recorder.
- * Confirm the program and sampling frequency.
- * In the following, the explanation will be on the assumption that a computer (with sequence software) is used.

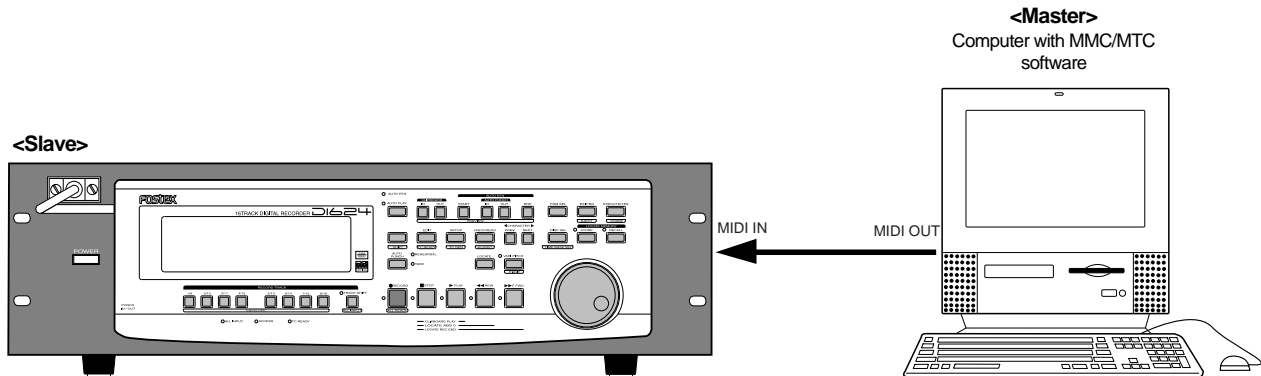

Connection to external equipment

Connect MIDI OUT of the computer (with MIDI interface) with MIDI IN of the recorder. The computer sequence software complying to MMC/MTC must be activated.

Setup of external equipment

Sequence software is setup as follows.

- * Set for output of MTC.
- * Set frame rate of the MTC to be output.
- * Confirm start time of the tune.

Refer to Owners Manual of the respective equipment for details.

Setup of the unit

1. Set to same frame rate as the sequence software by the SETUP mode "MTC Frame rate setting."

Refer to page "109", SETUP mode "MTC Frame rate setting" for operating procedure and details.

2. Set to the desired mode by the SETUP mode "MTC offset mode setting."

Refer to page "111", SETUP mode "MTC offset mode setting" for operating procedure and details.

3. A random offset time can be set by the SETUP mode "MTC offset time setting."

Refer to page "110", SETUP mode "MTC offset time setting" for operating procedure and details.

4. Press the EXECUTE/YES key holding down the SHIFT key, set the slave mode to "On."

5. Set slave type to “Vari” by the SETUP mode “Slave type setting.”

Refer to page “112”, SETUP mode “Slave type setting” for operating procedure and details.

6. Press the DISP SEL key while holding down the SHIFT key, to change the time base display to MTC.**<Precautions at MTC related setups>**

The position (ABS 0 or 001BAR/1BEAT/00CLK) when the setup MTC (MTC offset time) should be output was setup by the “MTC offset time setting” and “MTC offset mode setting.” In accordance to start time of the tune set by the sequence software, setup as explained below.

Offset mode: For ABS

Set the MTC offset time about three seconds prior to the start time of the tune set by the sequence software. Because the recorder cannot immediately chase lock after input of MTC, in order to sync the unit from head of the tune, set the preroll using the sequence software, and playback from before the actual head of the tune to allow the recorder to enter into sync by the time it arrives at the head of the tune.

Offset mode: For BAR/BEAT

The MTC offset time can be set to the same time as the start time of the tune set by the sequence software. Because the “ABS 0” position is set at the “0002BAR/1BEAT/00CLK” position in the unit, as mentioned before, the preceding time required for sync is already set. The preceding time of two bar lengths could change in length depending on the first bar’s “signature setting” and “tempo setting” mentioned before. For example, it will be longer if the tempo is slowed down.

Confirming chase lock**1. When the sequence software is played, MTC IN LED of the recorder will light, “CHASE” in the display will change from blinking to lit and the chase lock will be completed.**

Check that the MTC output by the sequence software and MTC time displayed in the recorder are the same.

2. When the sequence software stops, MTC will be interrupted and the recorder will also stop.

“CHASE” in the display will change from lit to blinking.

3. During FF/REW of the sequence software, the recorder will remain stopped but upon starting to record, the recorder will immediately chase lock.**<Note>**

Chase lock of the recorder by MTC only is permissible when speed difference of the MTC from the master is within +/- 5.6%. Against the MTC within this range, variable pitch will be constantly applied internally for chasing. Chase lock, however, will not function against MTC at a speed difference outside this range. Also, when the master speed difference is large, it is advised to let the recorder learn the master speed by entering PLAY prior to recording. By doing so, it will be lock faster from the second and later sessions.

* Should it not be possible to chase lock, re-check connections / cables and all settings.

Execution of recording

Carry out various recordings while the recorder is chase locked to the sequence software.

<One Point Advice>

Sync signal “Free” of the “Slave mode setting” menu:

When the recorder is made to chase lock by MTC only, variable pitch will be constantly applied by external MTC. If a digital signal is output to an external digital equipment from the recorder, it will not be able to follow the speed difference (MTC speed difference of the master) of the recorder and the external digital equipment, in some cases, may not be able to input a continuous digital signal.

As a counter measure, the sync signal should be set to “Free” by the “Slave mode setting” menu. Using this setting, the recorder will enter self operation by the internal clock, after completion of chase lock, and it will be possible to supply a stable digital signal to the external equipment.

Under this setting, when MTC drift between the master recorder and slave recorder exceeds 10 frames, the recorder will assume that chase lock has been disengaged and the slave recorder will carry out position matching again with the master unit (re-chase operation). During the re-chase operation, sound output will be muted and the digital signal will also be interrupted. If it is within 10 frames, the slave recorder will continue to run while admitting this drift.

Saving and Loading Song Data

The recorder allows you to select the data (audio data and Setup data) from a current Program and save it to a DAT machine as an S/PDIF digital signal or to an adat machine as an adat digital signal, or save it to a SCSI device. You can also re-load the saved data to the recorder. In particular, using a SCSI device enables you to save and load the data of all Programs (up to 99 Programs), as well as an individual Program. These save and load functions are convenient when you wish to store Programs (complete or in progress) temporarily to a DAT, adat, or SCSI device to clear enough space on the internal hard disk to make new recordings.

*******About saved and loaded data*******

The data format and time required to SAVE/LOAD song data will vary between saving and loading with a DAT using S/P DIF digital signals, saving and loading with an adat device using adat digital signals, or saving and loading with a SCSI device. Refer to the following explanation for more details.

S/PDIF digital signal (You can save and load each Program individually.):

Following about five seconds of pilot signal (shown in the diagram below), song data in the current drive is output to a connected DAT. Two tracks of audio data (shown in black in the diagram) are output. To save data from Real tracks 1-8, two-track data will be output four times, which takes twice as much time as the song duration (ABS 0 to REC END). To save all data including Additional tracks 9-24, two-track data will be output twelve times, which takes twelve times the song duration. Saved data is also loaded two tracks at a time.

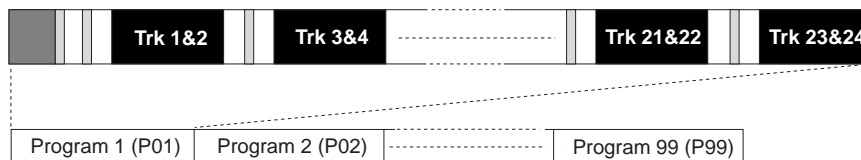

adat digital signal (You can save and load each Program individually.):

After about five seconds of pilot signal (shown in gray in the diagram below), song data in the current drive is output to a connected adat. Eight-track audio data (shown in black in the diagram) is output. To save the data from Real tracks 1-8, data will be output once, which takes the same amount of time as the song duration (ABS 0 to REC END). To save all data including Additional tracks 9-24, eight-track data will be output three times, which takes three times the song duration. Saved data is also located eight tracks at a time.

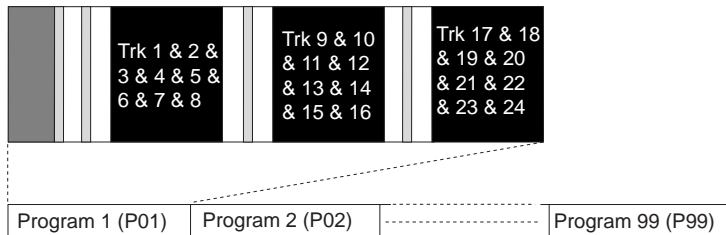

SCSI (You can save and load each Program individually or all Programs at once.):

All Real track data and Additional track data is output simultaneously to a SCSI disk as shown in black in the diagram. Therefore, saving and loading a Program takes much less time relative to a DAT or adat. No pilot signal or beep is recorded. If the available disk space is smaller than the song data size, you may use multiple disks (up to 99 disks) to save and load an entire song.

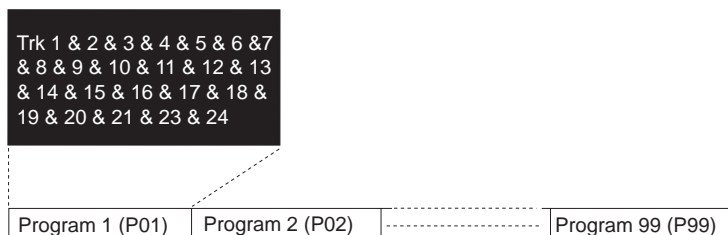

<The following items can be saved and loaded as song data>

Memory data: CLIPBOARD IN/OUT, AUTO RTN START/END, AUTO PUNCH IN/OUT point data
 Locate data (locate number 00~99): when saving and loading song data using SCSI
 Time Base: ABS, MTC, or BAR/BEAT/CLK
 Setup mode: * Time signature setting (BAR BEAT), * Tempo setting, * Click On/Off setting
 * Preroll Time setting, * Midi Sync Out setting, * MTC Frame Rate setting
 * MTC Offset setting, * MTC Offset Mode setting, * Rec Protect On/Off setting
 * Slave Mode on/off setting, * Slave Type setting, * Virtual TC Setting (when saving
 and loading song data using SCSI)

<The following items cannot be saved or loaded as song data>

Auto Play mode and Auto Return mode On/Off
 Vari-pitch mode On/Off, and pitch data
 Setup mode: * Digital In setting, * Digital Out setting, * Bar/Beat Resolution On/Off setting
 * Device ID setting

<Notes in using DAT and adat>

- * Execution of save/load is permissible only in 44.1kHz/16 bit, 44.1kHz/24 bit, 48kHz/16 bit or 48kHz/24 bit asynchronous recording in S/P DIF format, or with digital devices that have the adat format digital recording function.
- * When a 24 bit data recorded in the recorder is saved to a 16 bit digital device, Audio 16 bit only will be saved. Also, when a 20 bit data is saved, Audio 20 bit only will be saved.
- * When loading DAT or adat data, if it is 16 bit, even if the current drive of the recorder has been formatted in 24 bits, only the upper 16 bits will be loaded and the lower 8 bits will be "0." Likewise, in a 20 bit machine, the upper 20 bits only will be loaded and the lower 4 bits will be "0."

<Note when saving data using DAT or adat>

Song data can be saved as a real track, additional track or ALL data. Please note the following points when saving song data using a DAT or adat device.

The save time of the data depends on the time of the song data (ABS 0-REC END) on the real track. Therefore, if you attempt to save data that exists on an additional track that is longer than the data on the real track, the data on the additional track will only be saved for the same amount of time as the data on the real track.

Let's say, you have 10 minutes recorded on the real track and you tentatively move it to the additional track (track exchange function). Then you save a real track by leaving that moved portion blank, which leaves you with only 3 minutes of recording on the track. This means only 3 minutes of the data on the additional track will be saved, and the remaining 7 minutes will not be saved. If you want longer save time, you can edit the save time during save operations (Go to page "87" <Step-6>).

This can be done by either setting the save time to a longer save time (however, the maximum time that can be edited is 59 minutes 59 seconds), or move the data with the longest recording time on the additional track to the real track and then save that data. Be careful not to erase the data that you need on the additional track when conducting these procedures. For more details on track exchange go to page "72."

Saving the data using DIGITAL/DATA OUT

S/P DIF digital signal (or adat digital signal) from the DIGITAL/DATA OUT connector of the recorder is saved.

- * Restore the initial settings on the recorder.
- * Set the same sampling rate on the external digital device and the recorder.

Connecting an external device

Connect DIGITAL/DATA OUT connector of the recorder to the digital input connector on the external digital device.

<Note>

The recorder has DIGITAL/DATA OUT connectors for an S/P DIF digital signal (OPTICAL) and for an adat digital signal. These connectors have the same shape but carry different information. When using the D1624, use the DIGITAL/DATA OUT 1-8 connector to save data. Do not use the DIGITAL/DATA OUT 9-16 connector.

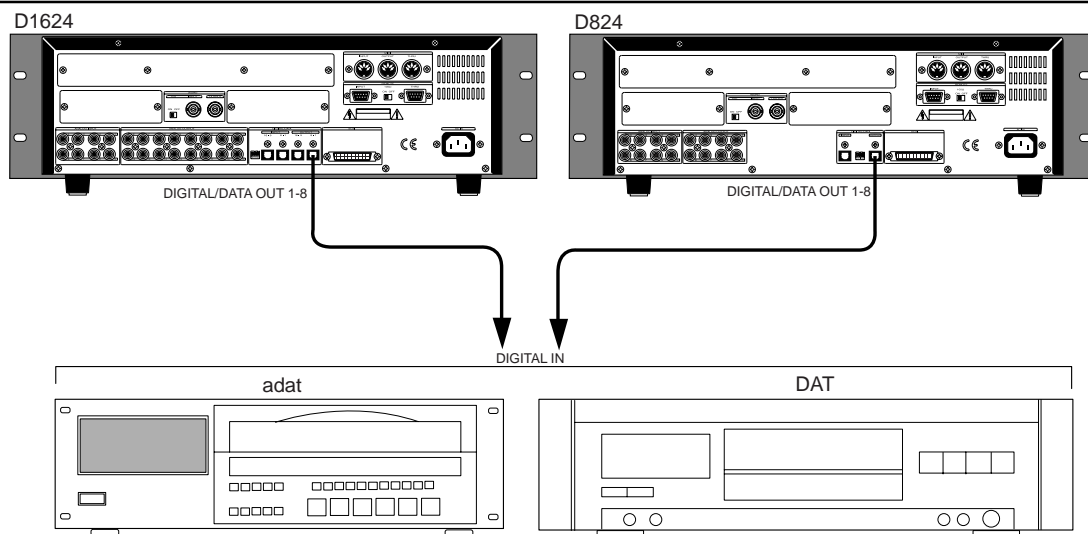

- * If the external device has only COAXIAL type (RCA) digital I/O connectors, connect an optional COP-1/96k (optical/coaxial converter) to use an S/P DIF digital signal.
- * Connecting both output and input connectors on the recorder to the input and output connectors on the external digital device respectively may generate a digital loop. Refer to "Connecting a digital mixer" on page "50" for more information.

Setting up an external device

1. Set the same sampling rate to that of the recorder.
2. Select digital input on the external device so that the external device will accept a digital signal.
On some external devices, you may have to set up so that the external device will synchronize with the incoming digital signal.

<Note>

If the external device does not accept the digital signal or if you notice digital noise, check the connection, cabling, and the settings of the recorder and the external device.

* Refer to the instruction manuals that came with any external digital device for details.

Executing the save operation

Use the "Save PGM?" menu in Setup mode.

- * Output format available : adat, DAT, SCSI 6
- * Programs available : P01 - P99
- * Track available : When using an adat or DAT: Tracks 1-8, Tracks 1-16, Tracks 1-24, Tracks 9-16, Tracks 9-24, Tracks 17-24;
When using a SCSI disk: All tracks will be automatically selected.

1. Press the SETUP key.

The recorder enters Setup mode.

2. Use the JOG dial to select "Save PGM?," and then press the EXECUTE/YES key.

The message "Save Device?" and an indication of the digital signal to be saved ("DAT," "adat," or "SCSI") will flash on the display.

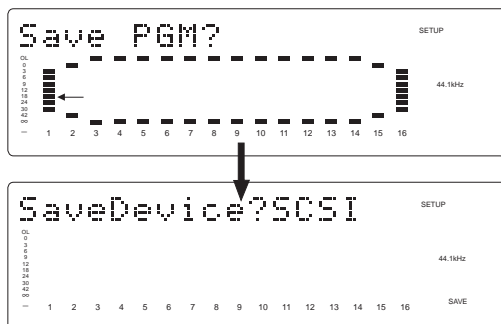

3. Rotate the JOG dial to select a type of digital signal format to be used for the save operation.

Selecting "adat" will save data in the adat digital signal format. Selecting "DAT" will save data in the S/P DIF digital signal format. Select "SCSI" if you are saving or loading data via SCSI. The following operation will be that when "adat" or "DAT" is selected for "Save Device?."

4. Press the EXECUTE/YES key.

Selection of the digital signal format for the save operation will be confirmed, and the existing Program numbers will flash on the display.

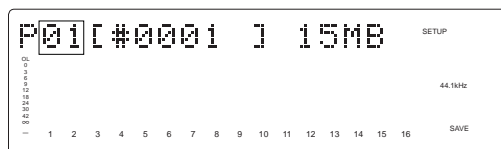

5. Rotate the JOG dial to select a Program to save.

You can select any existing Program (up to 99) to save.

6. Press the EXECUTE/YES key.

The length of the time (ABS 0 - REC END) of the program recording selected appears and the time shown can be edited. The time is usually saved according to the time displayed, however, it is possible to shorten the time to save at this stage when saving the time. In other words, though the actual recording may be 9 minutes 00 seconds, as shown in the example below, that time can be edited to 5 minutes when saved.

As mentioned in the <Note> on page 85, if the data on the additional track is longer the time can be set to a longer time and saved (however, the maximum time that can be edited is 59 minutes 59 seconds).

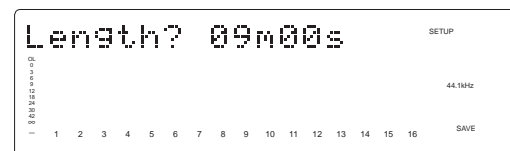

7. Press the EXECUTE/YES key again.

"Save Trk ? 1-8" ("1" is flashing) appears on the display and you can select tracks to save.

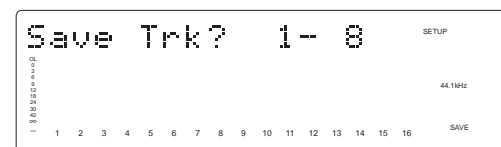

8. Select the desired track range using the JOG dial.

You can select 1, 9 and 17 of the points that are flashing (left). Use the SHUTTLE, NEXT key, or PREV key to move the flashing cursor to the left, then turn the JOG dial to select 8, 16 and 24. You can select track saving combinations from Tr1-16, Tr1-24, Tr9-16, Tr9-24 and Tr17-24, in addition to Tr1-8.

<Note>
Refer to the <Note> on page "85" prior to saving data including the additional track.

9. Press the EXECUTE/YES key.

"Rec Start DAT!" (Start recording on the DAT) or "Rec Start adat!" (Start recording on the adat) appears on the display, and "SURE?" flashes.



10. Confirm that the external device is syncing with the digital input signal, and start recording on the external device (DAT or adat).

Setting a START-ID (DAT) or a locate point at the recording start point will facilitate future loading operations.

11. Confirm that the recording on the external device has started, and press the EXECUTE/YES key.

The save operation starts, and the time required for the save operation appears on the display and a few seconds later, it will start counting down. This few seconds delay is due to the pilot signal which is recorded to mark the beginning of the Program to facilitate future load operation. Therefore, the actual save operation starts when counting down starts. Two tracks are saved each time in the order of Track 1 and 2, 3 and 4, etc. to a DAT machine. Eight tracks are saved each time in the order of Track 1-8, 9-16, etc. to an adat machine. The level meter indication during save of DAT will always be for only tracks 1 and 2 and always for tracks 1~8 in save of adat.

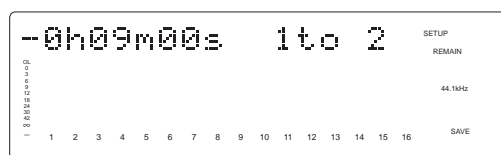

12. When data is successfully saved a "COMPLETED!" message will appear on the display, and stop the external DAT or adat.

13. Press the STOP button or the EXIT/NO key to quit the Setup mode.

The display will return to the previous time base indication.

* To cancel the operation or restore the indication shown before you pressed the EXECUTE/YES key, press the STOP button or the EXIT/NO key. Pressing one of these keys repeatedly takes you to the previous layer, finally quitting the Setup mode, and the display will return to the previous time base indication. If you press the STOP button or the EXIT/NO key any time after you execute the save operation but before it is complete, the saved song data will be invalid.

Loading the data using DIGITAL/DATA IN

Load the data by S/P DIF digital signals (or adat digital signals) from the DIGITAL/DATA IN jack of the recorder.

- * Restore the initial settings on the recorder.
- * Set the same sampling rate on the external digital device and the recorder.

Connecting the external device

Connect DIGITAL/DATA IN connectors of the recorder to the digital output connectors on the external digital device.

<Notes>

- * The recorder has DIGITAL/DATA IN connectors for an S/P DIF digital signal (OPTICAL) and for an adat digital signal. These connectors have the same shape but carry different information. When using the D1624, use the DIGITAL/DATA IN 1-8 connector. Do not use the DIGITAL/DATA IN connector.
- * Do not remove the optical cable or perform any other operation that would disconnect the S/P DIF signal until the session is complete. Otherwise, the recorder will generate noise, and affect the connected device.

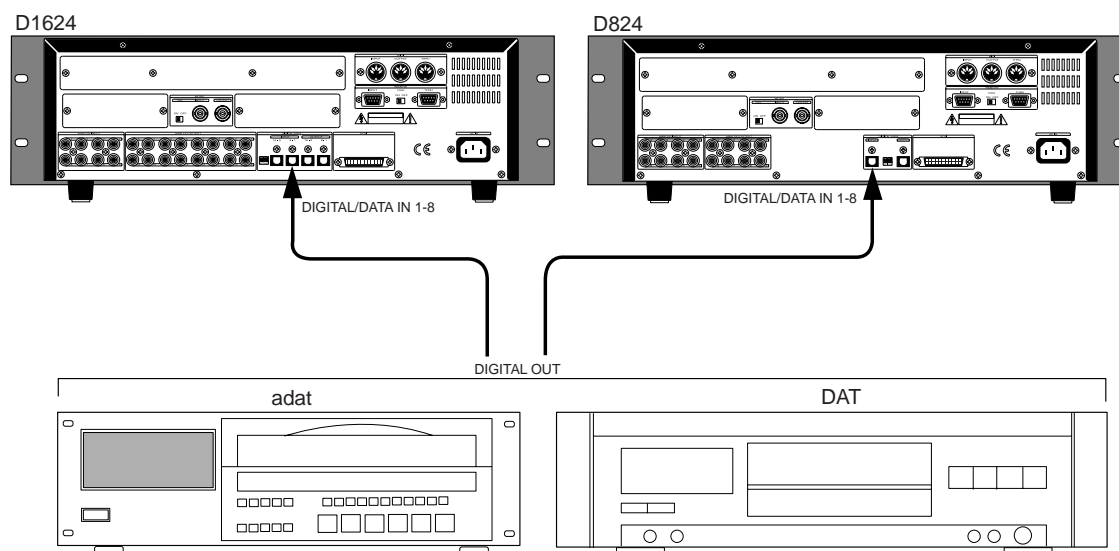

- * If the external device has only COAXIAL type (RCA) digital I/O connectors, connect an optional COP-1/96k (optical/coaxial converter) to use an S/P DIF digital signal.
- * Connecting both output and input connectors on the recorder to the input and output connectors on the external digital device respectively may generate a digital loop. Refer to "Connecting a digital mixer" on page "50" for more information.

Setting up an external device

1. Setup the external device so that it can output a digital signal.
2. Locate the beginning of the pilot signal recorded in the saved data.

* Refer to the instruction manual that came with your external digital device for details.

Executing the load operation

You will use the "Load PGM ?" menu in Setup mode.

- * Input format available : adat, DAT, SCSI (6)
- * Programs available : P01 - P99
- * Track available : When using an adat or DAT: Tracks 1-8, Tracks 1-16, Tracks 1-24, Tracks 9-16, Tracks 9-24, Tracks 17-24;
When using a SCSI disk: All tracks will be automatically selected.

1. Press the SETUP key.

The recorder will enter the Setup mode.

2. Use the JOG dial to select "Load PGM ?," and then press the EXECUTE/YES key.

The message "Load Device?" and the type of digital signal to be loaded ("DAT," "adat," or "SCSI") will flash on the display.

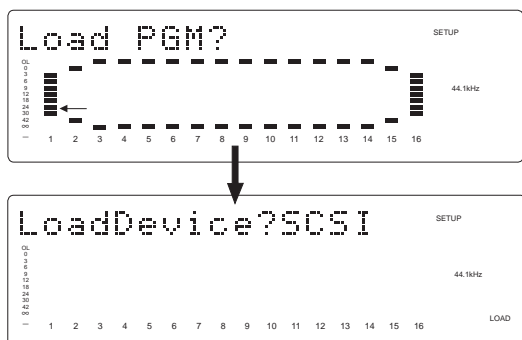

3. Rotate the JOG dial to select the type of digital signal format to be used for the load operation.

Selecting "adat" will load data in the adat digital signal format. Selecting "DAT" will load data in the S/P DIF digital signal format. Select "SCSI" if you are loading data via SCSI. The following operation will be that when "adat" or "DAT" is selected for "Load Device?."

4. Press the EXECUTE/YES key. ("SURE?" flashes.)

The digital signal selected is set and the program number currently set on the load destination current drive flashes. The size of the program recording is also displayed.

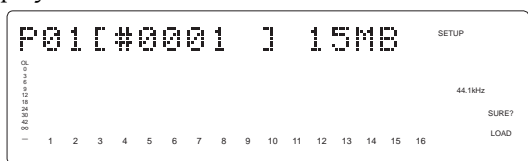

5. Rotate the JOG dial to select a Program into which to load data.

You can select any existing Program (from up to 99). If you select a Program that already contains data and execute the load operation, the existing data will be overwritten by the new data. If you do not wish to overwrite any data in any current Program, use the JOG dial to select "New PGM" to execute the load operation. You can do this only when the number of existing Programs is 99 or less and the hard disk has enough free space to accommodate the new data.

If a program that is already recorded with some sort of data is selected and loaded, only the song data loaded will be valid. All the data of the programs recorded on that same track up to then will be erased.

6. Press the EXECUTE/YES key.

Now you can select tracks into which to load.

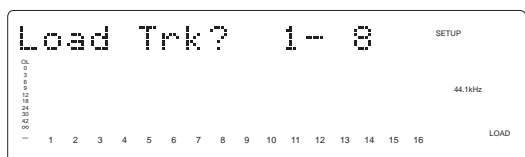

7. Select the desired track range using the JOG dial.

You can select 1, 9 and 17 of the points that are flashing (left). Use the SHUTTLE, NEXT key, or PREV key to move the flashing cursor to the left, then turn the JOG dial to select 8, 16 and 24.

You can select track loading combinations from Tr1-16, Tr1-24, Tr9-16, Tr9-24 and Tr17-24, in addition to Tr1-8.

8. Press the EXECUTE/YES key. ("SURE?" flashes.)

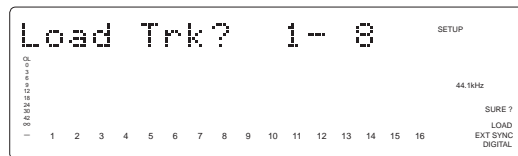

<Notes>

- * If digital signal is being input correctly, a red "DIGITAL" and "EXT SYNC" indicator will light up on the display. If the red "DIGITAL" and "EXT SYNC" indicator flashes, check the connection, cabling, and the settings of the recorder and the external device.
- * The FS indication will flash and warn you if the sampling frequency of the recorder and DAT vary when loading with S/P DIF digital signals. Be careful when setting the sampling frequency for adat digital signals because there will be no FS warning though there may be a discrepancy.

9. Press the EXECUTE/YES key again.

"Play DAT!" (Start playing the DAT) or "Play adat!" (Start playing the adat) appears on the display.



10. Play the corresponding external device (DAT or adat).

The load operation starts when the recorder accepts the incoming digital signal. The time required for the load operation appears on the display and starts counting down.

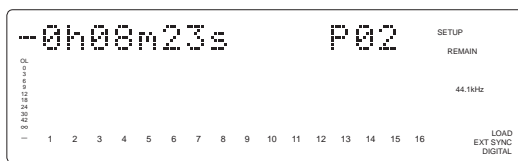

Two tracks are loaded at a time from a DAT machine in the following order: Track 1 and 2, 3 and 4, etc. from a DAT machine. Eight tracks are loaded each time in the order of Track 1-8, 9-16, etc..

11. When the load operation is complete, "COMPLETED!" flashes on the display.

12. Press the STOP button or the EXIT/NO key to quit Setup mode.

The display will indicate the time base set for the loaded Program.

Press the STOP button or EXIT/NO key to return to one previous menu prior to the EXECUTE/YES key or if you want to cancel a procedure. Everytime you press these keys you will move back one previous hierarchy, and eventually escape from the SETUP mode and return to the time base display. Note that all the song data saved will be invalid if you press the STOP button or EXIT/NO key while saving at <Step-10>.

Saving the data using SCSI

This procedure will SAVE/LOAD using a removable SCSI drive disk (zip, MO, DVD RAM etc.) that is a backup disk.

A backup purpose SCSI disk is generally used after formatted in the backup format, however, a DOS formatted (computer format) SCSI disk can also be used to SAVE/LOAD in WAV.

Data saved in WAV can be re-loaded and even directly be read by the computer. Therefore, this kind of data can be used as music software, as well.

Connecting a SCSI device

Refer to the diagram to connect a SCSI device to a D824 (D1624).

<Notes on connection>

- * Before making connections, make sure that both the recorder and the SCSI drive are turned off.
- * One SCSI drive may be connected on the recorder.
- * The SCSI connector on the recorder is a half pitch 50-pin connector compatible with Macintosh computers. Use a cable with connectors that conform to the standards for connecting a SCSI drive.
- * The SCSI drive should be terminated. Install a SCSI terminator, or turn the termination switch to "on" if the drive has a termination qswitch (like a zip drive).

<SCSI ID number setting>

- * Using the SCSI drive as a back-up drive Select "6."
- * You must format the SCSI disk after you connect it to the recorder. Refer to the "Formatting" section on the next page for the formatting procedure.

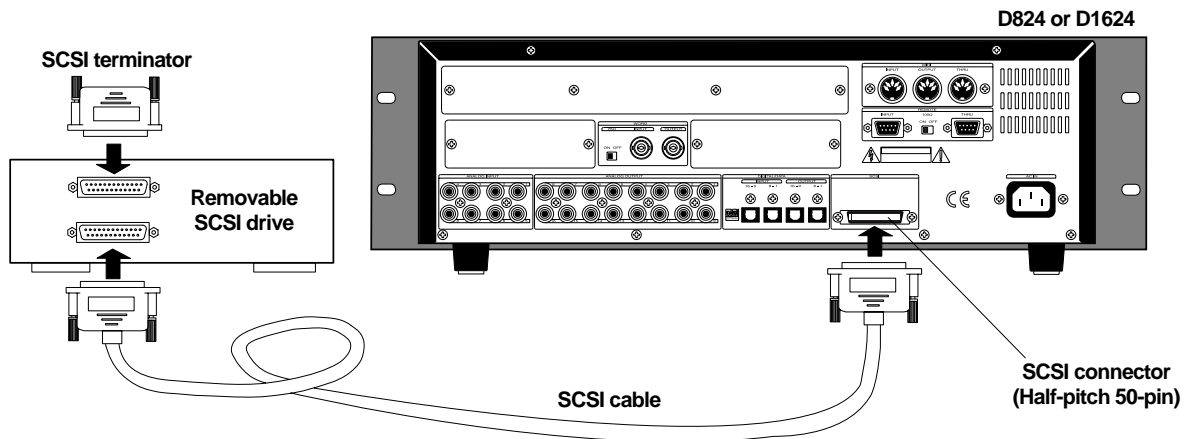

Formatting a SCSI disk

An unformatted disk or a disk used with the computer can also be used. Check to see that the data on the disk is no longer necessary prior to formatting a disk that was previously used with the computer. Once formatting is started it cannot be stopped. The formatting process will erase all data. Be especially careful not to erase the data that you still need. The prerequisite here is that a removable disk is used.

1. Connect the SCSI device to the recorder and turn the power on to the both machines.

2. If you are using a removable disk, insert the disk into the drive.

3. Press the SETUP key to enter the Setup mode.

4. Turn the JOG dial to select “Disk Format?” (“?” flashes), and press the EXECUTE/YES key again. “Disk Format IDE” (“IDE” flashes) appears.

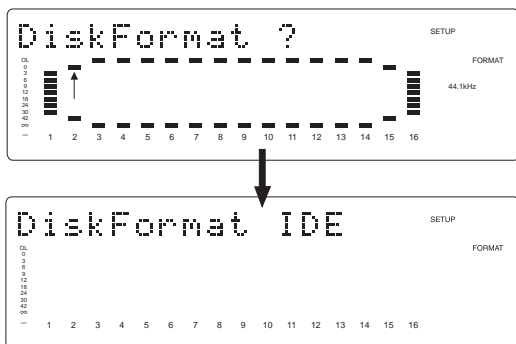

<CAUTION>

If format is executed while “IDE” is blinking, the internal IDE hard disk will be formatted and data in the IDE hard disk will be lost.

5. Rotate the JOG dial to display the flashing “SCSI6” and press the EXECUTE/YES key.

The ID number and name of the connected SCSI device appear on the display, and “?” and “SURE?” flash.

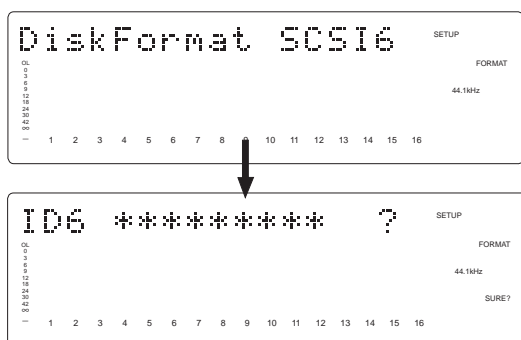

6. Press the EXECUTE/YES key.

The “Backup format?” (“?” flashing) message appears and “SURE?” flashes.

This indicates that you are in the stand-by mode to format the backup purpose SCSI hddisk in the “24 bit Backup Format”.



7. Press and hold down the RECORD button and press the EXECUTE/YES key.

“REMAIN” lights up and formatting starts.

As the formatting operation progresses, the size of the area to be formatted on the disk will count down on the display.

When formatting is complete, “COMPLETED!” will appear.

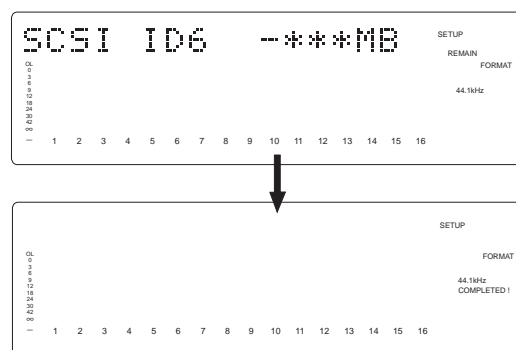

8. Press the EXIT/NO key or the STOP button to quit the SETUP mode.

The recorder returns to the ABS display of the Program that was selected before it entered Setup mode.

Your backup purpose SCSI disk has been formatted after completing the steps up to this point. The SCSI disk is now ready to SAVE/LOAD.

To continuously format another disk, remove the disk from the SCSI drive and then repeat the same procedures.

Press the eject switch on the SCSI drive to remove the disk from the SCSI drive.

Saving data of an individual Program

When saving with a SCSI disk it is possible to save each program or all programs. This section will explain the procedures to save each program.

* Output format available	: adat, DAT, SCSI 6
* Programs available	: P01 - P99
* Track available	: When using an adat or DAT: Tracks 1-8, Tracks 1-16, Tracks 1-24, Tracks 9-16, Tracks 9-24, Tracks 17-24; : When using a SCSI disk: All tracks will be automatically selected.

<Note>
Label each disk with a serial number (1, 2, 3...) prior to saving one program on several removable disks. This makes it easier to load the program, as explained later.

1. Press the SETUP key.

The recorder will enter the SETUP mode.

2. Use the JOG dial to select "Save PGM?" ("?" will flash.), and press the EXECUTE/YES key.

The indication of the type of digital signal to be saved will flash on the display.

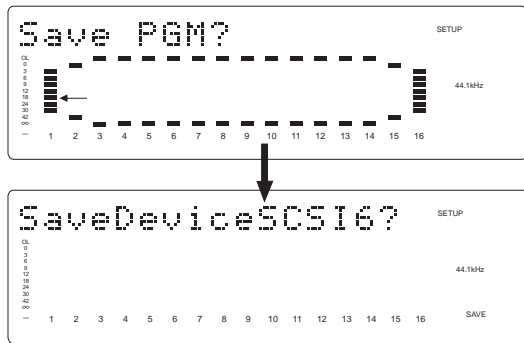

3. Rotate the JOG dial to select a flashing "SCSI 6," and press the EXECUTE/YES key. ("SURE?" flashes.)

The digital signal to save is set on "SCSI 6", the program number currently set on the current drive flashes.

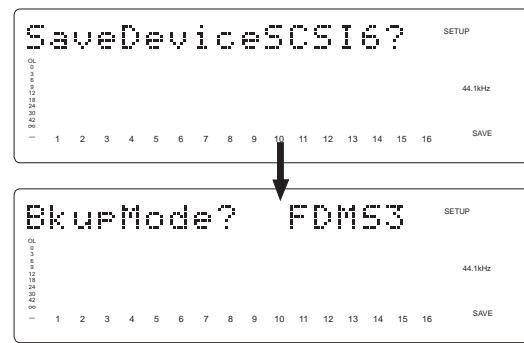

4. Rotate the JOG dial to select a Program to save.

You can select any existing Program individually or all Programs (Save All). (Refer to the next section for information on saving all Programs.) As mentioned previously, the display indication differs as follows depending on whether the selected Program to save requires only one removable disk or multiple disks.

*** If you have selected a Program that has no recorded:**

*** If you have selected a Program that requires only one disk to save:**

*** If you have selected a Program that requires multiple disks:**
The following indication, for example, appears. (**** is the tentative title, the program number flashes, the information on the size of the program and number of disks necessary, alternate.)
This display indicates that one SCSI harddisk is not enough to save the program chosen, and that several disks are necessary to proceed with the save procedure. In the following example you see a "2D" indication as the number of disks necessary. This indicates that 2 disks are necessary to execute the save procedure.

5. Press the EXECUTE/YES key. ("SURE?" flashes.)

The recorder performs the save operation differently depending on the selected Program.

*** When selecting a program that can be saved on one backup disk:**

The backup disk will indicate that a new program is going to be created (backup disk shows B01).

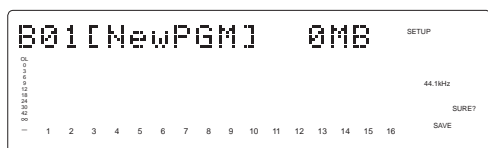

Pressing the EXECUTE/YES key will start save operations and then the following indication will appear. This indicates that the song data of the current drive selected is being saved on the B01 backup disk. The disk space necessary to save the data is counted down while the data is being saved.

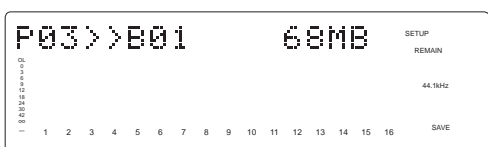

When the data is saved, the system goes to the program time base indication prior to going to the SETUP mode, then "COMPLETED!" lights up.

*** When selecting a program to save that requires several disks:**

Save will immediately start if the EXECUTE/YES key is pressed at <Step 7>. The save process appears as in the above case. When the first disk is full, that disk is ejected and the display will indicate "Insert second disk!".



Save is automatically resumed when the second disk is inserted in the SCSI drive. The same process is repeated when a third, or more disks are required. When the program is successfully saved on the last disk, the program time base indication (ABS 0) that was started up prior to entering the SETUP mode appears and "COMPLETED!" lights up.

8. Press the EXECUTE/YES key. ("SURE?" flashes.)

The recorder performs the save operation differently depending on the selected Program.

<Note>

You cannot interrupt the save operations on the SCSI harddisk, as with DAT or adat.

You will have to start the save process from the very first disk again, if you erroneously press the EXIT/NO key during the insertion of several disks required to save the program on.

Press the eject switch on the SCSI drive to remove the disk from the SCSI drive after the program has been successfully saved.

<Please remember this!>

The instructions on the left was based on use of disks that were already formatted for backup use, when saving programs using several disks.

It is recommended that all the disks to save data on are already formatted prior to the save process. However, there may be times that you will unexpectedly not have enough formatted disks during the save process thus, forcing you to use an "unformatted disk" or a "used disk" that already has other data saved on it. Observe the respective procedures described when inserting the disk according to the [Insert Disk 2] or [Insert Disk 3] message that prompts you to "Insert another disk!!" as shown in the instructions on the left.

*** When inserting an unformatted disk**

The recorder automatically recognizes an "Unformatted" disk, and will indicate [Unformat!], then automatically go to the [Disk Format?] menu in the SETUP mode, to format the backup disk.

Follow the formatting procedures to actually format the backup disk.

The save process automatically resumes when the disk is successfully formatted.

*** When inserting a disk that is saved or loaded with other data**

The following display may appear as an example, when inserting such type of disk. This prompt is asking you whether you want to erase the existing data saved on the disk that was inserted, and indicates that you have entered the [Delete PGM?] menu in the SETUP mode.

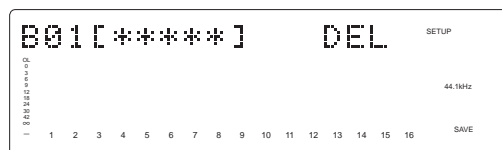

If it is okay to erase that disk, press the EXECUTE/YES key. The [Delete ALL PGM?] message will appear. Press the EXECUTE/YES key to delete all programs. Save is automatically resumed after the programs are deleted. If it is not okay to erase the disk, turn the JOG dial to select [Eject] when the above indication appears to eject the disk. Press the EXECUTE/YES key after [Eject] is selected.

When the disk is ejected, then a prompt to [Insert Disk] will appear on the display. Insert another disk.

*** When inserting a disk that was used as the current drive**

[Wrong Disk] will briefly appear, the [Disk Format?] menu of the SETUP mode will appear for backup formatting, then the following indication will appear.

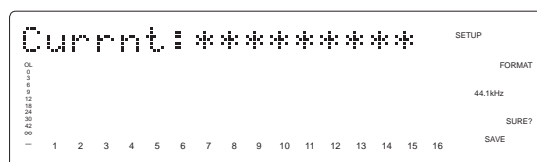

If it is okay to proceed formatting, then execute the formatting process as done in the above case. If it is not okay to proceed formatting, then turn the JOG dial to select [Eject] to eject the disk.

The save operations can automatically be resumed in such manner when the disk is formatted as a backup disk or when a program is deleted.

Loading the data using SCSI

Here you are loading on the current drive, the data of each program or the data of all programs saved on the backup purpose SCSI disk. The prerequisite is that a backup SCSI drive is connected to the recorder.

Load the data saved on one removable disk.

Load the program with the “Load PGM?” menu in the SETUP mode. This assumes that a saved disk is inserted in the backup purpose SCSI drive.

* Input format available : adat, DAT, SCSI 6
 * Programs available : P01 - P99
 * Track available : When using an adat or DAT: Tracks 1-8, Tracks 1-16, Tracks 1-24, Tracks 9-16, Tracks 9-24, Tracks 17-24;
 When using a SCSI disk: All tracks will be automatically selected.

1. Press the SETUP key.

The recorder will enter the SETUP mode.

2. Use the JOG dial to select “Load PGM?” and press the EXECUTE/YES key.

An indication of the type of the digital signal to be loaded will flash on the display.

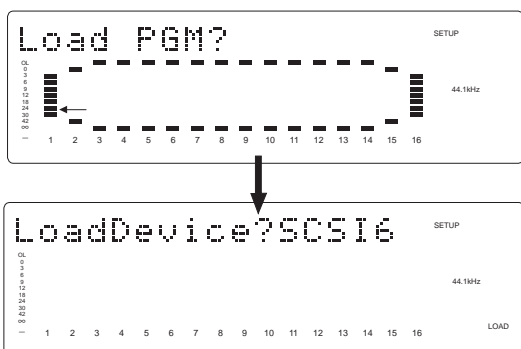

3. Rotate the JOG dial to select a flashing “SCSI 6,” and press the EXECUTE/YES key.

The external digital device is set to “SCSI 6,” and the existing Song numbers will flash on the display.

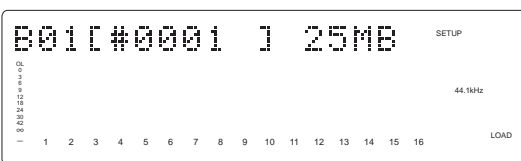

4. Rotate the JOG dial to select the back up number to load.

You can choose to load any existing Song individually or all Songs collectively. The display indication differs as follows depending on whether you selected an individual Song number or all Song numbers.

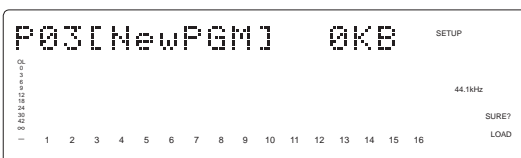

Turning the JOG dial in this state makes it possible to select another program, other than the above, on the current drive. The size of the program appears when the program is selected.

If you select a program that is already recorded with data and load is executed for the load destination, the existing data is deleted while loading takes place.

If you do not want to overwrite the existing data, select “New PGM” mentioned above, prior to loading.

When the load operation is complete, “COMPLETED!” will light and the recorder will display the Time Base that was shown before the unit entered the Setup mode.

5. Press the EXECUTE/YES key.

Song data will be loaded to the selected Program. If, for example, backup 1 is started for Program 1, then “B01 >> P1 ***MB” will appear, “REMAIN” lights up, load proceeds, and “***MB (program size)” is counted down, when individual programs are loaded.

When the load operation is complete, “COMPLETED!” will light and the recorder will display the Time Base that was shown before the unit entered the Setup mode.

6. Press the STOP button or the EXIT key.

“COMPLETED!” will turn off.

<Note>
 You cannot abort a load operation on a SCSI device while it is in progress.

Loading data saved on several removable disks

As an example here, we will load the data of a Program saved onto two removable disks.

1. Insert the first disk (Disk-1) into the SCSI device.

<Note>

Make sure that you insert the disks in the correct order. If you insert the wrong disk, the recorder displays [Wrong disk] -> [Illegal No!] and ejects the disk.

Follow the disk markings you made during the save operation.

2. Follow Steps 1-3 of the “Loading Song data” procedure.

The display flashes the number of the existing Backup data in the SCSI disk, and then indicates that the first disk has been inserted.

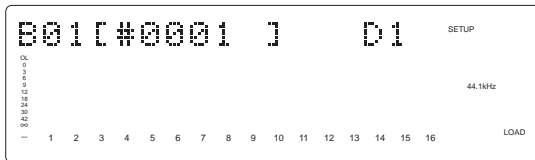

Rotating the JOG dial will toggle between “B01” and “Eject.” If you wish to cancel the load operation and remove the disk, select “Eject” and press the EXECUTE/YES key.

3. Press the EXECUTE/YES key after “B01[#0001]D1” appears.

A prompt inquiring whether to set a new program on the current drive which is the load destination will appear. ([New PGM] appears and [SURE?] flashes.)

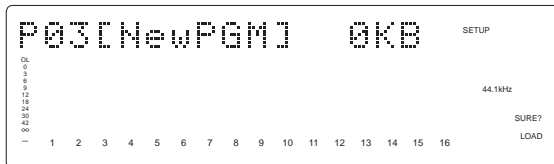

Turning the JOG dial in this state makes it possible to select a program on the current drive. The size of the program appears when the program is selected.

If you select a program that is already recorded with data and load is executed for the load destination, the existing data is deleted while loading takes place.

If you do not want to overwrite the existing data, select “New PGM” mentioned above, prior to loading.

4. Press the EXECUTE/YES key after selecting the program.

Loading is started and the display will show “B01 >> P** ***MB”. This indicates that the backup data (B01) on the SCSI harddisk is being loaded on the current drive program (P**).

The “***MB” (load size) is counted down as loading proceeds.

When Disk 1 loading is completed, an “Insert Disk 2” message appears, and Disk 1 is automatically ejected.

5. Insert Disk 2 (second disk) into the SCSI hard disk drive according to what the display requests.

Loading automatically resumes when Disk 2 is inserted.

The display will show the same count down as shown for Disk 1. The size of the program is counted down along with the load process.

When all data is loaded, “COMPLETED!” lights up, and the program time base (ABS 0) started up prior to going into the SETUP mode will appear.

<Note>

You cannot abort a load operation on a SCSI device while it is in progress.

6. Press the EXIT/NO key, or STOP button.

The “COMPLETED!” go off.

SAVE/LOAD by "WAV" file

In addition to save/load by the aforementioned FDMS-3 (Fostex Disk Management System-3), save/load to a DOS formatted disc by using WAV (RIFF WAVE file format, hereafter called WAV) file is possible. In the same way as the aforementioned "Save/Load by FDMS-3," it is possible not only to save data from this recorder but also to read data by this recorder; because data in WAV file is saved to the backup disk, the computer can read/write it directly and therefore, playback/editing the WAV file using various software is possible. Additionally, WAV files edited with a computer can be read by this recorder.

< Notes when using a WAV file >

THE BACKUP DISK:

* **SCSI equipment used to save/load WAV files must always be set to "SCSI ID 6."**

* **Save/load by WAV file is possible only to disks formatted in DOS FAT 16.**

This recorder will execute save/load by WAV file only when this DOS disk is acknowledged by SCSI ID 6. Disks DOS formatted in FAT 32 will not be acknowledged.

* **DOS formatting using the SETUP mode "Disk Format?" menu is not possible.**

Consequently, backup disks to be used for WAV file must be formatted in FAT 16 before being used.

If a disk of more than 2GB is formatted in FAT 16, the disk will be partitioned to a maximum 2GB capacity.

In this case, this recorder will acknowledge the first partition only; the other partitions will not be acknowledged.

As a result, the maximum capacity for the backup disk used by this recorder will always be 2GB for one disk drive.

At save/load by WAV file, it is recommended to use a newly formatted disk to prevent loss of data due to overwriting.

DIRECTORY OF THE BACKUP DISK:

* **The saved WAV file will be recorded in the root directory (first level) of the backup disk.**

* **WAV files that can be loaded must be placed in the root directory of the backup disk.**

WAV files that have been moved from the root directory to another location such as a different folder, cannot be acknowledged by this recorder and could cause a malfunction.

FILE NAME OF THE "WAV" FILE:

* **WAV files saved by this recorder will be recorded under the file name of "*****##.WAV."**

* **WAV files which can be loaded by this recorder must have a file name of "*****##.WAV."**

The first 6 letters "*****" will be the title displayed by "Title Edit?" in the SETUP mode. These 6 letters can be changed at save of the WAV file and also edited by the computer.

The latter 2 letters "##" represent each track number (1-24) at save/load of the WAV file.

The last "WAV" is the extension to indicate that this file is a WAV file. File names other than those described here will not be acknowledged by this recorder. For details, refer to each procedure.

Using these specifications, WAV files can be loaded in any single track or tracks exchanged and loaded in the WAV file. Refer to "Loading of WAV files" in later pages.

Saving of "WAV" files

A WAV file is saved by the following procedure. Before proceeding to save, make sure a DOS formatted disk in FAT 16 is set in the SCSI ID6 equipment. The following explains the procedures for using a backup disk after it had been formatted.

1. The SETUP mode is entered by pressing the SETUP key.

The display will change to the SETUP mode menu.

2. Select "Save PGM?" ("?" blinks) with the JOG dial and press the EXECUTE/YES key.

The currently setup content (adat, DAT or SCSI) will flash in the display.

3. Select the flashing "SCSI6" with the JOG dial and press the EXECUTE/YES key.

After displaying [drive name], the display will change to [Bkup Mode?] for selecting the backup mode ([WAVE] will flashes).

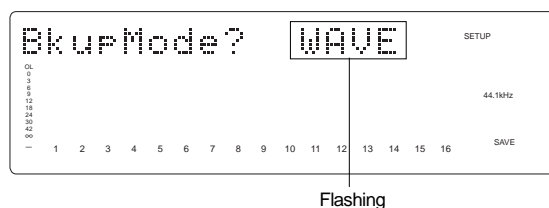

4. Select the backup mode [WAVE] with the JOG dial and press the EXECUTE/YES key.

The display will change to [CB Export? OFF] (OFF flashes) and ON-OFF of the clip board export can be setup.

Normally, when saving ABS 0-REC END data, proceed to the next step while the setup is OFF.
But, under the following condition, save is executed with the setup ON.

< Please remember! >
When clip board export is set to ON, save is to be executed only on data within a desired range. In such a case, the desired range must be registered by the CLIPBOARD IN and CLIPBOARD OUT points previous to executing save. For explanation on registering of CLIPBOARD IN/OUT points, refer to [Registering of the locate point (=editing point) on page 54.

5. Select [OFF] and press the EXECUTE/YES key.

The display will change to selecting the program for saving.

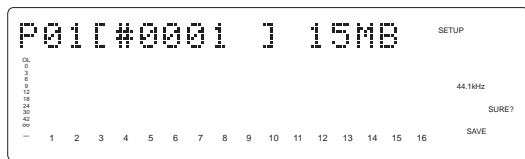

6. Select the desired program with the JOG dial and press the EXECUTE/YES key.

The display will change to selecting the track to be saved. In the initial state, [All Trk] will flashes.



If the JOG dial is rotated at this stage, in addition to [All Trk] (flashing), [01-01] (flashing)-[24-24] (flashing) can be selected. This function is used when specifying any desired track and saving it.
For example, if tracks 5-24 must be saved, [05-05] is selected. Then proceed to the following.

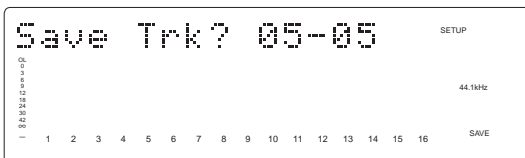

7. After selecting the track, press the EXECUTE/YES key.

If [All Trk] or any desired track was selected, the display will change to the following.

When [All Trk] is selected:

The display will change to making a new WAV file on the disk and [SURE?] will flashes.

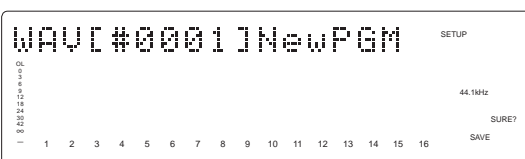

When the JOG dial is rotated, [Eject] can be selected. To eject the disk, select [Eject] and press the EXECUTE/YES key.

If [05-05] is selected:

The Flashing [05-05] will change to flashing only of the right [05].

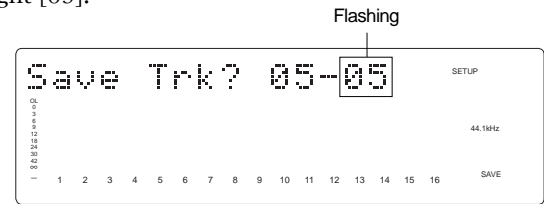

The last track can be selected. After setting to [05-24] by rotating the JOG dial and pressing the EXECUTE/YES key, the display will change the same as the previous [WAV#0001]New PGM]. Numbers that can be selected for the right two digits must be greater than the left two digits (In this example, either of 05-24). This means that if the track was specified as [05-05], track 5 only will be saved.

8. Press the EXECUTE/YES key.

The display will change for entering the file name for the WAV file.



If the JOG dial is rotated at the flashing point, any desired number/symbol/alphabet can be input. The flashing point can be moved with the SHUTTLE dial. Characters which can be input are limited to the following:

Alphabet capitals (A-Z)
Numbers (0-9)
Symbols (!, #, \$, %, &, ', (,), @, ^, _, -)

Although up to 6 letters can be input for the file name, some of the letters/symbols/alphabets input here will be converted as follows.

Alphabet capitals (A-Z) -> No conversion
Alphabet small letters -> (a-z) Converted to capitals
Numerals (0-9) -> No conversion
Symbols -> No conversion
Other symbols -> Under bar is converted to “_”

9. After inputting a file name, press the EXECUTE/YES key.

Save will be executed and the following displayed. During save, the capacity display will continue to count down. For a case where a multiple number of disks are required, disks will automatically eject and the next disk must be loaded.
At completion of save, the display returns to the original time base and [COMPLETED!] will light.

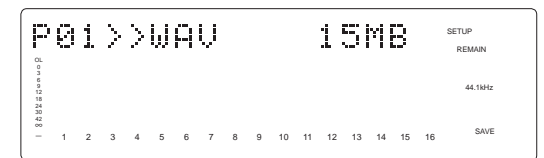

<Note>
If you attempt to save a WAV file with the same name as an existing WAV file on the backup disk, [Already Exist] (The same file already exists) will be displayed and save cannot be executed. For details, refer to the later “Using a backup disk in which a program is already saved.”

10. Press the EXIT/NO key or STOP button.

[COMPLETED!] is extinguished.

Press the EXIT/NO key or STOP button in the event you must return to the previous step or interrupt the procedure.

“WAV” FILE WHICH WAS SAVED

*** Composition of WAV file**

A WAV file on the backup disk is made, one file to one track in the root directory, for a total of 24 files. File names will be from “*****01.WAV” to “*****24.WAV.” “*****” is the file name specified in above and numbers 0124 correspond to each track. An unrecorded track will be made as one file for “Data number zero.”

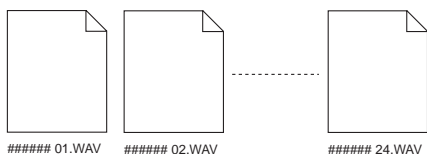

*** Composition of WAV file on multiple discs**

WAV files are saved in order from track 1 through track 24. When saving on a multiple number of backup disks, remaining space is constantly calculated automatically and should the capacity on the track for saving the next WAV file be insufficient, the disk is exchanged with the next one.

*** Capacity of the WAV file**

After saving a WAV file, in some cases the capacity will increase compared to the current drive capacity.

For example, depending on the status of the recording such as record starting time and ending time or size of the recorded and unrecorded length, in some cases capacity will increase. For example, in the case of a track, which is recorded from ABS:0 minute to ABS:1 minute, and from ABS:10 minutes to ABS:11 minutes, in the current drive it will be “2 minutes” file but in the WAV file, it will be a file of “11 minutes.”

Also on the unrecorded track, capacity will increase as a “data zero” and a WAV file (small capacity) will be made.

*** When using a backup disc in which a program is already saved.**

If a program is already saved in the backup disk, depending on the remaining capacity, the following selectable item may be added to the Step 6 Save Method.

These can be selected by rotating the JOG dial.

[Title] & [Eject] display

The present disk must be removed and return to Step 5. This is selected when another disc is to be used.

[Title] & [New PGM] display

There is enough remaining capacity to make a new WAV file in addition to a WAV file on the disk. Press the EXECUTE/YES key and proceed to Step 7. When saved to the disk, this WAV file will be additionally recorded.

Alternate display of [Title] & [New PGM] and [-###MB]

Disk capacity is short by the amount of “-###” to be able to add a new WAV file. Press the EXECUTE/YES key

and after display of [Disk Full], [Delete All WAV?] is displayed, then, press the EXECUTE/YES key again, and it will go to Step 7 for deleting all WAV files on the backup disk. After save, only saved WAV files will be recorded.

[Title] & [###MB] display

In this instance, the selected WAV file on the backup disk is deleted and there is now enough capacity to make a WAV file. Press the EXECUTE/YES key and [DEL] (delete of WAV file) will be displayed, and when EXECUTE/YES key is pressed again, it will go to Step 7 for deleting the selected WAV file on the backup disk. After save, the selected WAV file will be replaced as the new file and recorded on the disk.

[Title] & [-###MB] display

The disk is short of capacity by the amount of “-###” to be able to make a WAV file although the selected WAV file on the backup disk is deleted. If the EXECUTE/YES key is pressed, after display of [Disk Full], [Delete All WAV?] is displayed, and when the EXECUTES/YES key is pressed again, it will go to Step 7 for deleting all WAV files on the backup disk. After save, only saved WAV files will be recorded.

< Notes >

* If you attempt to save a WAV file with the same file name as one already existing on the backup disk, [Already Exist] (Same file name already exists) is displayed and save will not be executed. In this case, change the WAV file name by the previous Step 7.

* In a disk which had been repeatedly saved by overwriting, access speed could be lowered due to file fragmentation. We recommend that you use a disk immediately after formatting for backup purposes.

* In a save requiring a multiple number of backup disks, if the backup disc already saved with programs is used, [Delete All WAV?] (Delete of all WAV files) will be displayed due to [Disk Full] and all WAV files will be deleted. For save on multiple number of disks, we recommend that you use a disk immediately after formatting.

* When files and folders other than file names “*****##.WAV” which can be acknowledged by this recorder are made on the backup disk by using a computer, in some cases save cannot be completed as it cannot calculate the accurate remaining capacity of the backup disk. Great care should be taken when changing file names and making folders by a computer.

Loading WAV files

WAV files will be loaded. Prior to this, make sure the backup disk is connected to the SCSI ID6 equipment. The following explains how to use a backup disk in which WAV files were saved by this unit.

1. Enter the SETUP mode by pressing the SETUP key.

The SETUP mode menu will be displayed.

2. Select "Load PGM?" ("?" flashes) with the JOG dial and press the EXECUTE/YES key.

The currently set content will be displayed (flashing).

3. Select the flashing "SCSI 6" with the JOG dial and press the EXECUTE/YES key.

After display of [Drive name] and [DOS format], the WAV file name and its capacity is displayed and [SURE?] will flash at the same time.

"No SCSI Disk!" will be displayed if no disk is loaded.

4. Select the WAV file to be loaded with the JOG dial.

If a multiple number of WAV files with different file names (Beginning 6 letters) have been saved, the WAV file names (beginning 6 letters) and capacity will be sequentially displayed. If [Eject] is selected, the backup disc can be removed.

<Note>
 File names other than "*****#.WAV" cannot be acknowledged nor loaded by this recorder. WAV files with the beginning 6 letters of the file name will be individually acknowledged and can be selected.

5. Select WAV file, then press the EXECUTE/YES key.

The display will change to selecting the track to be loaded. [All Trk] will flashes. If the JOG dial is rotated at this stage, [01]-[24] (mono tracks) can also be selected in addition to [All Trk].



6. Select the track, then press the EXECUTE/YES key.

The display will change to selecting the program to be loaded (current drive). The program can now be selected with the JOG dial.

The [Title] & [New PGM] now displays the WAV file to be loaded.

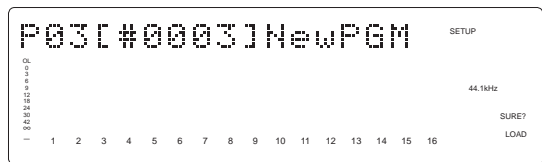

The [Title] & [Capacity] display changes to the WAV file program to be loaded by deleting the selected program.

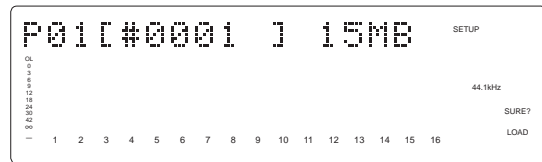

<Note>
 If there is insufficient capacity in the current drive to load a WAV file, the capacity will be indicated in minus as [-###]. In such a case, select a program of a the right size or delete an unnecessary program by using the SETUP mode "Delete PGM##."

7. After selecting the program to load, press the EXECUTE/YES key.

Loading is immediately executed when loading a new program ([Title] & [New PGM]).

If program loading for replacing had been selected ([Title] & [Capacity] is selected), [Overwrite?] and [SURE?] will be displayed.

Load is executed when the EXECUTE/YES key is pressed again.

The following will be displayed during load. As load progresses, the capacity indication will count down. Upon completion of the load, the display will return to the original time base and [COMPLETED] is displayed.

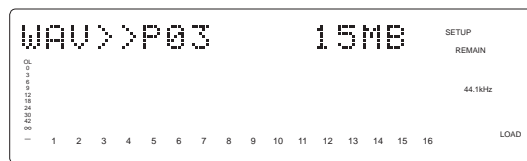

<Note>
 The title of the loaded program will be replaced by the WAV file name (beginning 6 letters) which is loaded.

8. Press the EXIT/NO key or the STOP button.

[COMPLETED] will be extinguished.

Press the EXIT/NO key or the STOP button to return to an earlier step or stop.

<< Special loading method when using a computer >>

< Note>

WAV files which can be saved/loaded by this recorder must have file names written as "*****##.WAV."
 Other file names cannot be acknowledged by this recorder.
 Unknown file names will not be acknowledged and could cause malfunction. Extreme care should be taken when changing file names and making folders on a computer.

- * The first six letters will be the title shown in the SETUP mode "Title Edit" display.
- * The last two letters "##" represent each track number (1-24) of the WAV file which are to be saved/loaded.
- * The last "WAV" is the extension which indicate that this is a WAV file.
- * File name of the WAV file which is to be saved in the backup disk of this recorder will all be recorded in capital letters. However, in certain computers, this WAV file name will be displayed in small letters.

(*) Method to load specific tracks.

The backup disk in which files are saved will contain files from "*****01.WAV" up to "*****24.WAV." Should these files be deleted, moved from the root directory, for example, into a another folder or the file name changed which cannot be acknowledged, this recorder will not recognize this file.

When a backup disk changed in this manner is loaded, only WAV files with file names "*****##.WAV" which are located in an acknowledgeable root directory can be loaded.

For example, if the "zero number of data" made at save is deleted from the backup disk and then load is executed, only WAV files recorded with any other sound can be loaded.

(*) When loading WAV files saved in a multiple number of disks, they can be loaded by a special method derived from the above method.

Assume that there is backup disc 1 saved with "*****01.WAV" through "*****12.WAV" and disc 2 saved with "*****13.WAV" through "*****24.WAV."

First, when backup disk 1 is loaded, files in tracks 1-12 will be loaded. At this point, tracks 13-24 will not be loaded and thus be non-recorded. Next, when backup disk 2 is loaded, files in tracks 1-12 remains intact and tracks 13-24 only will be loaded.

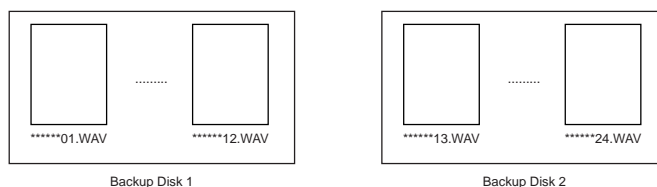

(*) Method in loading by changing the track.

If the two letters "##" in file name "*****##.WAV" in the backup disk are changed, it will be possible to load them on this recorder on a track different from that at the initial save. For example, if a WAV file named "ABCDEF01.WAV" on track 1 is changed to "ABCDEF03.WAV" this WAV file will be loaded on track 3.

(*) Method in loading by changing the title.

If the 6 letters "*****" in file name "*****##.WAV" in the backup disk are changed, it will be possible to load them on this recorder under a title different from that at the first save. Letters which can be used at changing the file name in a computer are those only indicated below. All of these letters must be one byte size.

Alphabets	: A-Z and a-z
Numerals	: 0-9
Symbols	: !#\$%&'()@'_ =

Changing the Initial Settings (SETUP mode)

The SETUP mode offers the Changing the initial settings menus to configure the operating environment of the recorder, a “Check” menu that enables you to check the number of events of each track and the “Execution” menus to execute certain operations such as save/load and disk formatting.

The “Changing the initial settings” menus include 21 parameters as shown in <Table-1> below. These parameters were set before the recorder was shipped from the factory and are called the initial settings. By modifying these settings, you can change the operating environment of your recorder. The “Check” menu provides two parameters as shown in <Table-2> : Checking the number of events and Checking the current drive information.

The “Execution” menus in <Table-3> include six items: Title Edit?, Delete. PGM?, Load PGM?, Save PGM?, Disk Optimize, and Disk Format?, which you can execute by selecting the corresponding SETUP menu. In this chapter we will explain procedures only on <Table-1> “Changing the initial settings” menu (except setting the internal clock) and <Table-2> “Check” menu. To learn how to set the internal clock, refer to the “Quick operation guide,” and on the “Execution” menu, the “Reference page” written in <Table-3>.

<Table-1> “Changing the initial settings” menu

Parameters	Display	Default setting	Refer page	Community
Setting a time signature	Signature Set ?	001bar 4/4	103	○
Setting a Tempo	Tempo Map Set ?	001bar 1↓120	105	○
Setting the metronome function	Click ↓ ?	Off	107	○
Setting a preroll time	Preroll Time ?	00s	108	○
Setting MIDI sync output signal	Midi Sync Out ?	MTC	109	●
Setting an MTC frame rate	Frame Rate ?	25 frame	109	○
Setting an MTC offset value	MTC OFFSET	00h 59m 57s 00f 00sf	110	○
Setting Offset mode	Offset Mode ?	ABS	111	○
Setting a reference time code	Ref. TC ? Void!	Available with option Model 8345 (Refer to APPENDIX)		
Setting the slave type	Slave Type ?	Vari	112	○
Setting the record protect function	Rec Protect ?	Off	112	○
Setting digital input tracks	D. in?	Analog	113	●
Setting digital output tracks	D. out ?	adat	114	●
Setting BAR/BEAT resolution mode	↓Resolution ?	Off	115	●
Setting the MIDI device ID number	Device ID ?	00	116	●
Setting the operating clock	Clock Sel ?	Int.	117	●
Setting the SYNC preset	Sync Preset ?	Available with option Model 8345 (Refer to the APPENDIX)		
Setting the Virtual LTC display	Virtual LTC ?	Available with option Model 8345 (Refer to the APPENDIX)		
Setting the chase offset display	Offset Disp ?	Available with option Model 8345 (Refer to the APPENDIX)		
Setting the drive	Drive Sel. ?	IDE	121	-
Setting the internal clock	Date & Time Set ?	Please refer to the “Quick Operation Guide.”		

○ : Modes applicable program by program. They can be saved/loaded.

● : Modes applicable to all programs. They cannot be saved/loaded.

<Table-2> “Check” menu

Check item	Display	Refer page	Community
Check of the Event number on the track	NOs Of Event ?	118	-
Check of the current drive status	Drive Info ?	119	-

<Table-3> “Execution” menu

Execution item	Display	Refer page	Community
Editing a program title	Title Edit PGM** ?	37	-
Deleting a program	Delete PGM** ?	36	-
Loading song data	Load PGM ?	84	-
Saving song data	Save PGM ?	84	-
Optimizing a Disk	Disk Optimize ?	30	-
Formatting a Disk	Disk Format ?	30	-

Selecting SETUP mode

Follow the steps below to select the desired SETUP menu in SETUP mode.

1. While the recorder is stopped, press the SETUP key on the control panel.

Pressing the SETUP key causes the recorder to enter SETUP mode. The recorder displays the first hierarchy level of the SETUP menu you selected before you turned off the power. At this time, the menu graphic appear as shown below. The flashing menu indicator is the currently-selected menu. Turning the JOG dial will select a different menu and the corresponding menu indicator will flash.

<Note>

With the factory initial settings, or when you turn on the power again after you format a current drive disk, "Signature Set? (Setting a signature)" appears. Otherwise, the first hierarchy level of the previously-selected SETUP menu appears.

To exit SETUP mode, press the STOP button or the EXIT/NO key. Each time you press one of these keys, the recorder returns to the previous hierarchy level of the menu, and finally exits SETUP mode.

The title of the SETUP menu appears. You can select a different menu via the JOG dial.

This lights up when the recorder enters SETUP mode.



This indicates the position of the SETUP menu. Selecting a menu via the JOG dial will move the flashing cursor.

2. Select the desired menu using the JOG dial, then press the EXECUTE/YES key.

The recorder displays the second hierarchy level of the selected SETUP menu, where you can set parameters.

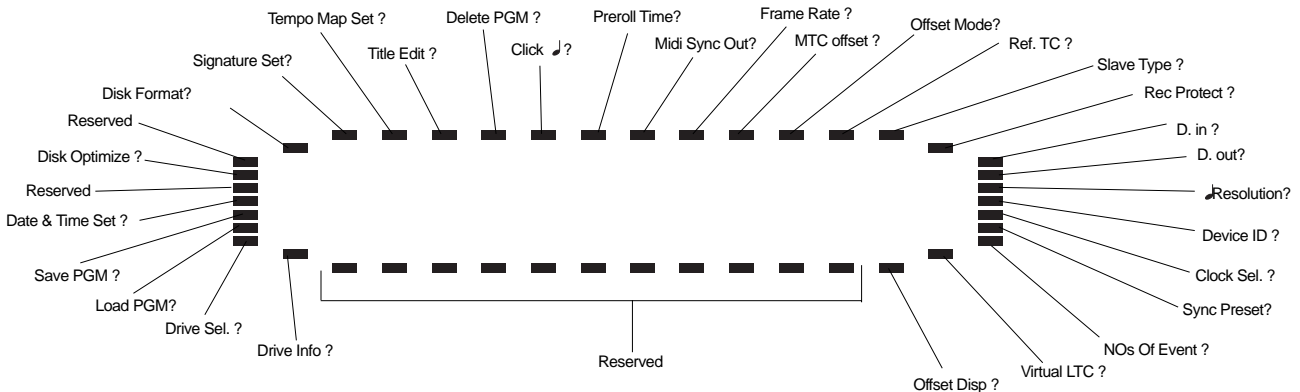

<Note>

Although titles of the "Ref. TC ?" menu, "Offset Disp ?" menu, "Virtual LTC ?" menu and "Sync Preset ?" menu will also be displayed, these menus will only function when an optional Model 8345 TC/SYNC card is installed. Refer to the APPENDIX for details. "Reserve" is the extra position for future extension of the SETUP mode menu.

Time Signature Setting (“Signature Set?”)

Using the “Setting a time signature” menu, you can set a time signature of a given measure on the internal programmable Tempo Map. And also in this setting, the BAR (-002bar, 1♩, 00clk) displayed at the head of the disk in the time base BAR/BEAT/CLK can be set within the range of -009bar ~ -002bar. For example, you can specify “4/4 for the first and second measures, and 2/2 from the third measure.” Setting a time signature and tempo will create a Tempo Map, which allows the recorder to manage a song using the BAR/BEAT/CLK Time Base. You can also use the Metronome function.

A time signature and tempo setting are required when MIDI clock & song position pointer are output to an external sequencer.

- * Initial Setting : 001bar 4/4 beat
- * Available bars : 001 ~ 999
- * Available time signature : 1/4, 2/4, 3/4, 4/4, 5/4, 1/8, 3/8, 5/8, 6/8, 7/8, 8/8, -/- (Delete)
- * Maximum setting points : 64
- * The setting is applicable song by song.
- * The setting can be saved or loaded as a part of the song data
- * The setting is memorized even when the power is off.
- * Make sure you choose the right program before setting this mode.

Storing a time signature

1. Select a Program for which to set a time signature.

Refer to “Using the Program Change function” on page “36” for information on selecting a Program.

2. Press the SETUP key, use the JOG dial to select the [Signature.Set ?] menu, then press the EXECUTE/YES key.

The indication changes to the current time signature appears. The initial setting is [001bar 4/4♩] (4/4 for the first measure).

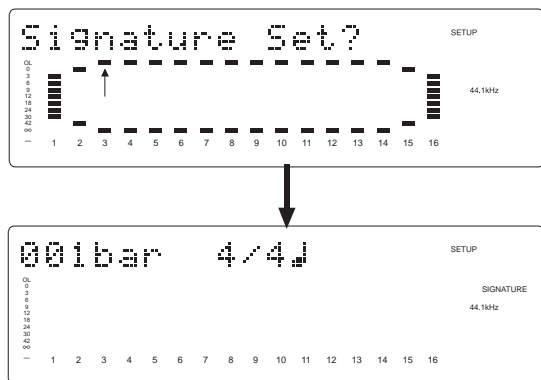

At this time, rotating the JOG dial clockwise enables you to check the current time signatures in sequence. With the initial setting, time signatures after the first measure are all [- -bar -/♩]. This means that a time signature of 4/4 applies to all measures.

3. Press the EXECUTE/YES key.

The indication changes to [001 (measure)] of [001bar 4/4♩] flashes. You can enter any time signature here.

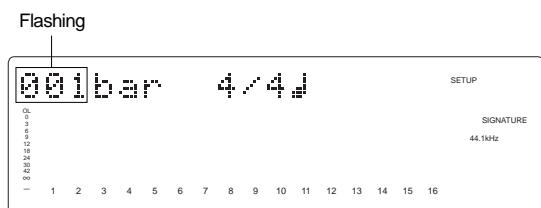

• Rotate the JOG dial to enter the desired measure number.

If you wish to keep the initial setting for the first measure, enter 002. If you try to enter any number other than 001, the time signature indicator shows [-/- ♩]. This means that no time signature is set for any measures other than the first measure. To change the time signature for the first measure, follow the steps below, without entering any other measure number.

• Turn the SHUTTLE dial to display flashing [-/-] of [-/- ♩] and enter the time signature using the JOG dial.

The following measure numbers and time signatures can be entered via the JOG dial.

Measures	001-999, selection of [All Clear?] indication. [All Clear?] means that data in its entirety will be cleared. This is used to initialize the parameter. (Refer to “Clearing stored time signature/tempo data.”)
Time signatures	1/4, 2/4, 3/4, 4/4, 5/4, 1/8, 3/8, 5/8, 6/8, 7/8, 8/8, -/- [-/-] means no time signature assigned, and is used to delete time signature data. (Refer to “Modifying (or deleting) stored time signatures” for more information.)

<Note>
You cannot assign “- -” to measure 001.

4. Press the EXECUTE/YES key whenever you enter a pair of measure/time signature values.

Repeat this step to specify the necessary time signature for the measures.

To cancel the setting operation, or to exit SETUP mode after storing data, press the STOP button or the EXIT/NO key. Each time you press one of these keys, the recorder returns to the previous hierarchy level of the menu, and finally exits SETUP mode.

Modifying (or deleting) stored time signatures

- 1.Repeat steps 1-3 described in the “Storing a time signature” section.
- 2.Turn the SHUTTLE dial so that the flashing cursor is on the time signature value.
- 3.Use the JOG dial to enter a new value.
Entering [-/-] deletes the existing data. Note that you cannot enter [-/-] for measure 001.
- 4.Press the EXECUTE/YES key.
- 5.Press the EXIT/NO key (or STOP button).

<Caution>

If modifying or deleting the stored time signature causes the bar/beat setting for the tempo specified in the “Setting a tempo” menu to disappear, the tempo setting will also be automatically erased.

To cancel the setting operation, or to exit SETUP mode after storing data, press the STOP button or the EXIT/NO key. Each time you press one of these keys, the recorder returns to the previous hierarchy level of the menu, and finally exits SETUP mode.

Clearing all time signature and tempo settings

<Caution>

Using this function will erase not only the time signature setting but also the tempo data specified in the “Setting a tempo” menu described in the next section.

- 1.Repeat steps 1-3 described in the “Storing a time signature” section.
- 2.While the measure number is flashing, turn the JOG dial counter-clockwise to select [All Clear ?].
When [All Clear ?] appears, [SURE ?] flashes, and you can clear the time signature and tempo data in the next step.

- 3.Press the EXECUTE/YES key.

The stored time signature and tempo data in its entirety are cleared, and the initial settings are restored.

- 4.Press the EXIT/NO key (or STOP button).

To cancel the All Clear operation, press the STOP button or the EXIT/NO key now. Each time you press one of these keys, the recorder returns to the previous hierarchy level of the menu, and finally exits SETUP mode.

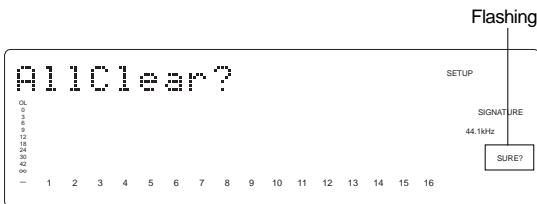

Changing the bar at ABS “0” of the time base

Bar in -002bar/1beat/00clk, which indicates the head figure of the disk in the time base BAR/BEAT/CLK, can be changed. Although the initial figure is -002bar, this can be set within the range of -009bar ~ -002bar.

- 1.Repeat steps 1-2 described in the “Storing a time signature” section.
- 2.Turn the JOG dial counter-clockwise to select [-002 bar Offset].
- 3.Press the EXECUTE/YES key.
[2] in [-002bar] will flash and the bar figure can be changed with the JOG dial (Numbers that can be input are 2~9.)

4. Use the JOG dial to enter a new value.

5. Press the EXECUTE/YES key.

6. Press the EXIT/NO key (or STOP button).

To cancel the setting operation, or to exit SETUP mode after storing data, press the STOP button or the EXIT/NO key. Each time you press one of these keys, the recorder returns to the previous hierarchy level of the menu, and finally exits SETUP mode.

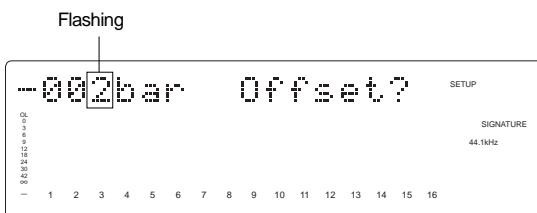

Setting a tempo (“Tempo Map Set ?” menu)

The “Setting a tempo” menu enables you to specify a tempo at a given point in a song that already has a time signature setting. For example, you can specify a tempo of 150 to the third beat of the 12th measure. Time signature and tempo settings make a Tempo Map, which is used by the recorder to manage the song using the BAR/BEAT/CLK Time Base, and enable the Metronome function. Tempo settings as well as time signature settings are required when you wish to output MIDI clock and Song Position Pointer to an external sequencer.

<Note>
 The tempo set figure setup here is an approximate figure and not 100% accurate. Therefore, although the tempo map be matched to a personal computer, they will gradually drift apart. In order to prevent this drift, the personal computer side can be set to either MIDI Clock Sync or, the MIDI sync output signal temporarily set to “MIDI Clock,” the figure reset to the accurate tempo and then return again to MTC sync.

- Initial setting: bar 001, beat 1: 120 (001 bar 1 beat 120 tempo)
 - Setting range of measures: Determined by the time signature setting.
 - Setting range of beats: Determined by the time signature setting.
 - Setting range of tempo: 30-250/quarter note, — (delete)
 - Max. setting points: 64 points
- * You can set the tempo for each Program individually.
 * The settings can be saved and loaded as part of song data.
 * The settings are maintained after you turn off the power to the recorder.

Checking the stored tempo setting

1. Select a Program to check the tempo setting for.
 Press the SETUP key, use the JOG dial to select the [Tempo Map Set ?] menu, then press the EXECUTE/YES key. Indication on the display changes as shown below, and the current tempo appears. The initial setting is [001 bar 1 ♩ =120]. This means that a tempo for the first beat of the first measure is set to 120.

2. Rotate the JOG dial clockwise.
You can view the current tempo values in sequence.
 Tempo value [- - - bar ♩ ♩ = - - -] means that no tempo values are specified after the current setting. With the initial setting, [001 bar 1 ♩ =120] is followed by [- - - bar ♩ ♩ = - - -].

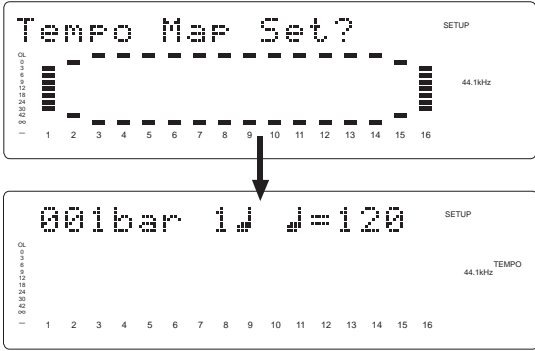

Storing a tempo value

3. Press the EXECUTE/YES key.
 The indication changes to [001 (measure)] of [001bar] flashes. (See the figure below.) This means that you can enter a value now.

4. Turn the SHUTTLE dial to move the flashing cursor to the desired edit location, and use the JOG dial to enter the bar/beat/tempo information to be stored.

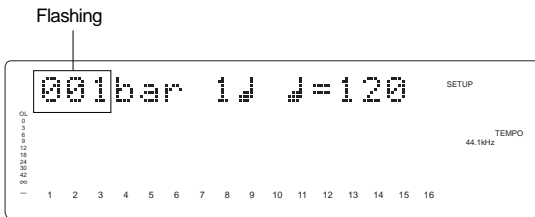

The bar and beat settings for the time signatures determine the setting range of bar and beat settings for the tempo. You can specify a tempo between 30 and 250 per quarter note. The indication [♩ = - - -] means “no tempo,” which is used to delete a tempo setting. When you turn the JOG dial, [♩ = - - -] appears for the bars and beats for which no tempo has been set.

5. Press the EXECUTE/YES key.

The display shows the stored bar/beat/tempo, then returns to the Tempo Edit indication (as shown in step 4).

6. Repeat steps 3-5 to store necessary tempo data.

For example, if you specify tempo values in the song with [001bar 4/4] and [005bar 3/4] settings, the Tempo Map includes the settings shown in the table below.

Tempo Map	
Time signature setting	Tempo setting
001 bar 4/4 ♩	001 bar 1 ♩ = 120 003 bar 1 ♩ = 90
005 bar 3/4 ♩	005 bar 3 ♩ = 60 007 bar 2 ♩ = 120

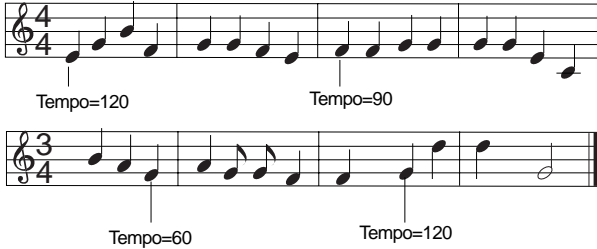

Modifying (or deleting) stored tempo settings

1. Repeat steps 1-3 described in the “Storing a tempo value” section.
2. Turn the JOG dial to select bar/beat to edit or delete.
3. Turn the SHUTTLE dial so that the flashing cursor is on the TEMPO number.

4. Use the JOG dial to enter a new value.
Entering [- -] deletes the data at the selected bar/beat.
5. Press the EXECUTE/YES key.
6. Press the STOP button or the EXIT/NO key repeatedly to exit SETUP mode.

Setting the Metronome function (“Click ?” menu)

“Setting the Metronome function” menu allows you to determine whether or not the recorder outputs a metronome sound from Real track (D824=track 8, D1624=track 16) during playback or recording. Turning the Metronome function on enables you to record your performance while playing the instrument accompanying the metronome sound.

<Notes>

- * The metronome sound is output from track 8 in the D824 and from track 16 in the D1624.
- * When the metronome function is switched ON, the metronome sound cannot be recorded on the output track nor can the recorded sound be played back. However, in a D1624 formatted in 96kHz/24bit (track 8), as the metronome sound will be output from track 16, real tracks 1-8 can all be used for record / playback.

- Initial setting: [Off]
- Option: [Off], or [On]
- * You can turn the function on and off for each Program individually.
- * The settings cannot be saved and loaded as part of the song data.
- * The settings are maintained after you turn off the power to the recorder.

Setting the Metronome function

1. While the recorder is stopped, press the SETUP key to enter SETUP mode.

2. Turn the JOG dial to select [Click ?] ([?] flashes.), then press the EXECUTE/YES key.

The current setting ([Off] or [On]) appears on the display. Pressing the EXECUTE/YES key lights up the flashing [?] character steadily; the current setting flashes. The initial setting is [Off] as shown below.

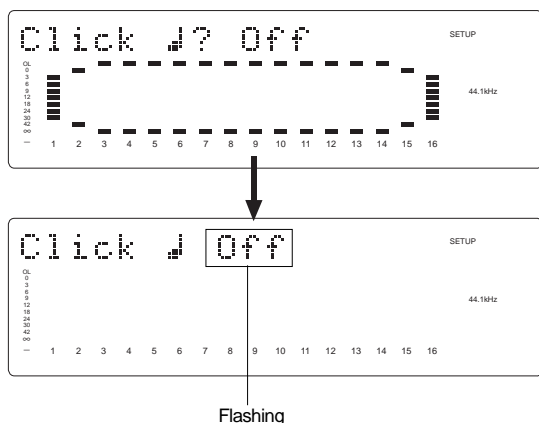

3. Turn the JOG dial to select [On] or [Off].

Selecting [On] will enable the output of the metronome sound. Selecting [Off] (initial setting) will disable the metronome output.

4. Press the EXECUTE/YES key.

The display shows the selection (On or Off), then returns to the indication in step 2.

To cancel the setting operation, or to exit SETUP mode after storing data, press the STOP button or the EXIT/NO key. Each time you press one of these keys, the recorder returns to the previous hierarchy level of the menu, and finally exits SETUP mode.

Setting a preroll value (“Preroll Time ?” menu)

The recorder features the Preroll function that enables you to locate a position a few seconds prior to a specified locate point. The “Setting a preroll value” menu allows you to set the preroll time (in seconds). The Preroll function is convenient when you wish to monitor the audio data from a point slightly before the locate point.

- Initial setting: [00] second
- Setting range of preroll time: [00]-[10] seconds in one second steps
- * You can set the value for each Program individually.
- * The settings can be saved and loaded as part of the song data.
- * The settings are maintained after you turn off the power to the recorder.

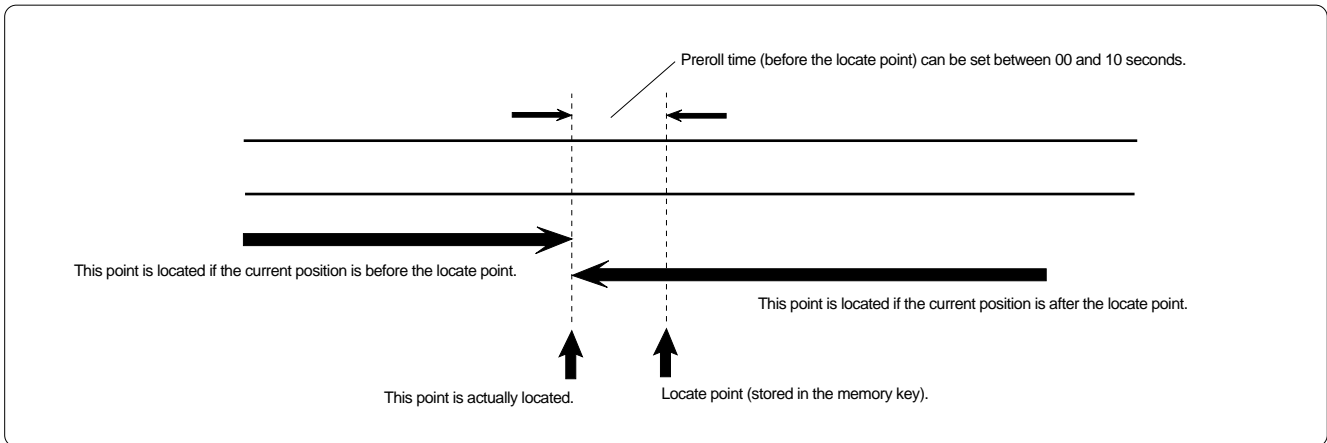

Setting a preroll time

1. While the recorder is stopped, press the SETUP key to enter SETUP mode.

2. Turn the JOG dial to select [Preroll Time ?] ([?] flashes.), then press the EXECUTE/YES key.

The current preroll time setting appears on the display. Pressing the EXECUTE/YES key lights up the flashing [?] character steadily; the current setting flashes. The initial setting is [00] as shown below.

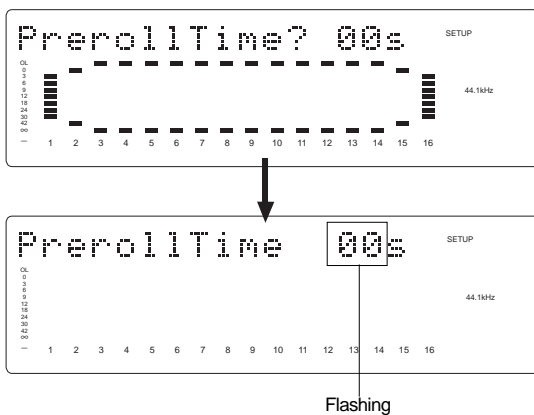

3. Turn the JOG dial to enter a desired preroll time value.

You can set a value in one-second increments. Rotating the JOG dial clockwise increases the value, and rotating it counter-clockwise decreases the value.

4. Press the EXECUTE/YES key.

The display shows the value, then returns to the indication that appeared in step 2.

To cancel the setting operation, or to restore the setting obtained prior to the EXECUTE/YES key press, press the STOP button or the EXIT/NO key. Each time you press one of these keys, the recorder returns to the previous hierarchy level of the menu, and finally exits SETUP mode and displays the previous Time Base.

Setting MIDI sync output signal (“Midi Sync Out ?” menu)

The “Setting MIDI sync output signal” menu enables you to select the type of MIDI sync signals output from the MIDI OUT connector on the rear panel of the recorder to an external MIDI device.

The options are MIDI clock & Song Position Pointer, or MTC (MIDI time code). Select an appropriate option depending on the type of signal supported by the connected MIDI device.

If you select MIDI clock & Song Position Pointer, first you need to set the time signatures and tempo as described previously. If you select MTC, you first need to set the MTC frame rate, the MTC offset time, and the MTC offset mode as described later.

- Initial setting: [MTC] (clock & Song Position Pointer)
- Option: [CLK] (clock & Song Position Pointer), [MTC] (MIDI time code), [Off] (no output)
- * You can set the parameters for each Program individually.
- * The settings can be saved and loaded as part of the song data.
- * The settings are maintained after you turn off the power to the recorder.

Setting MIDI sync signal

1. While the recorder is stopped, press the SETUP key to enter SETUP mode.

2. Rotate the JOG dial to select [Midi Sync Out ?] ([?] flashes.), then press the EXECUTE/YES key.

The currently-selected MIDI sync signal type appears on the display.

Press the EXECUTE/YES key to turn off the flashing [?] indication. The MIDI sync signal type indication flashes, and the indicator flashes indicating the SYNC OUT setting.

The initial setting is [MTC] as shown below.

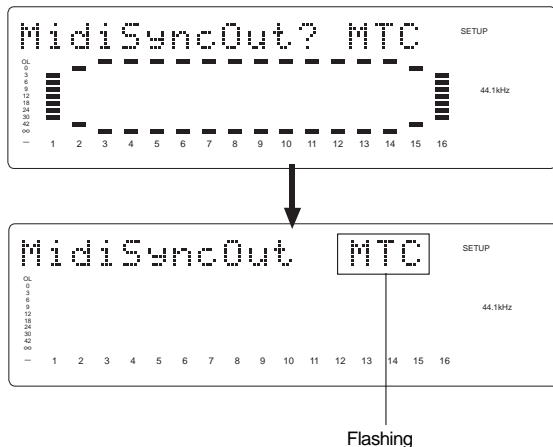

3. Turn the JOG dial to select the desired MIDI sync signal.

Setting this parameter to [CLK] will select MIDI clock & Song Position Pointer.

Setting the parameter to [MTC] (initial setting) will select MIDI time code.

With the [Off] setting, no MIDI sync signal will be output.

4. Press the EXECUTE/YES key.

The selected MIDI sync signal type is stored, and the recorder returns to the display with the flashing [?] indicator as shown in step 2.

To cancel the setting operation, or to restore a setting obtained prior to the EXECUTE/YES key press, press the STOP button or the EXIT/NO key. Each time you press one of these keys, the recorder returns to the previous hierarchy level of the menu, and finally exits SETUP mode and displays the previous Time Base.

Setting an MTC frame rate (“Frame Rate ?” menu)

The “Setting an MTC frame rate” menu enables you to set the frame rate for MTC output from the MIDI OUT connector of the recorder to an external MIDI device. If you have already set the type of MIDI sync output signal to [MTC], you need to set the frame rate. Use the frame rate of MTC received by the external MIDI device (or sequence software).

- Initial setting: [25] (25 frames)
- Setting range of frame rate: [24], [25], [29df], [29nd], [30df], [30nd]
- * You can set the value for each Program individually.
- * The settings can be saved and loaded as part of the song data.
- * The settings are maintained after you turn off the power to the recorder.

Setting an MTC frame rate

1. While the recorder is stopped, press the **SETUP** key to enter **SETUP** mode.

2. Turn the **JOG** dial to select [**Frame Rate (?)**] (**[?]** flashes), then press the **EXECUTE/YES** key.

The current frame rate setting appears on the display. Press the **EXECUTE/YES** key to turn off the flashing [**?**] character; the current setting flashes. The initial setting of [**25**] flashes as shown below.

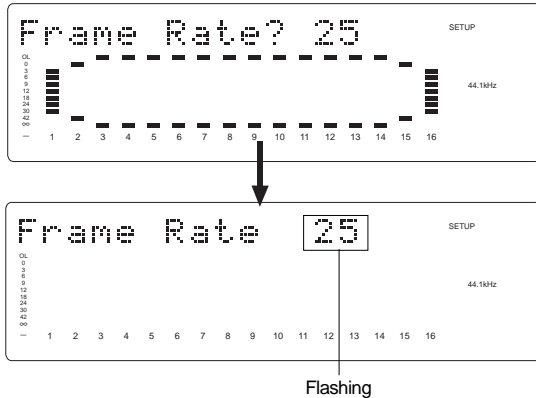

3. Turn the **JOG** dial to enter the desired frame rate.

Rotating the **JOG** dial clockwise or counter-clockwise displays available frame rates as an alternative.

4. Press the **EXECUTE/YES** key.

The selected frame rate is stored and the display returns to the indication with a flashing [**?**] that appeared in step 2.

*To cancel the operation, or to restore the setting obtained prior to the **EXECUTE/YES** key press, press the **STOP** button or the **EXIT/NO** key. Each time you press one of these keys, the recorder returns to the previous hierarchy level of the menu, and finally exits **SETUP** mode and displays the previous **Time Base**.*

<Note>

There are no 29.97nd or 29.97df in the MTC standard. Use either 30nd or 30df unless you definitely need to synchronize the recorder with NTSC video.

Setting an MTC offset value (“MTC OFFSET” menu)

The “Setting an MTC offset value” menu enables you to specify an offset time value - the difference between the time of MTC output from the recorder and the ABS 00m 00s 00f 00sf time. You need to specify this value if you have selected [**Mtc**] for the “Setting MIDI sync output signal” menu.

With the initial setting of 00h 59m 57s 00f 00sf, for example, MTC of 59m 57s 00f 00sf is output at the ABS time 00m 00s 00f 00sf. You can also set an offset value from the 001bar 1beat 00clk value (bar/beat) on the Tempo Map. Refer to the next section for information on MTC Offset mode.

- Initial setting: 00h: 59m: 57s: 00f: 00sf
- Setting range of offset time: 00h: 00m: 00s: 00f: 00sf - 23h: 59m: 59s: 29f: 99sf
- * You can set the value for each Program individually.
- * The settings can be saved and loaded as part of the song data.
- * The settings are maintained after you turn off the power to the recorder.

Setting an MTC offset

1. While the recorder is stopped, press the **SETUP** key to enter **SETUP** mode.

2. Turn the **JOG** dial to select [**MTC OFFSET**] (**[MTC OFFSET]** flashes.), then press the **EXECUTE/YES** key.

The current offset value appears on the display. Pressing the **EXECUTE/YES** key turns off the flashing [**MTC OFFSET**] character, and the value in seconds flashes. You can enter a value at the flashing digit. The number [**57**] of the initial setting [**57s**] flashes as shown below.

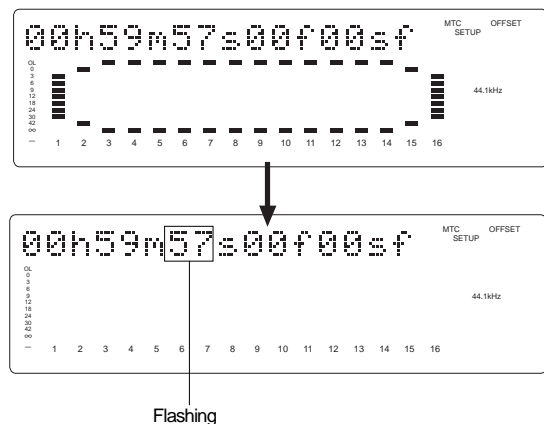

3. Use the SHUTTLE dial to move the flashing cursor, and turn the JOG dial to enter the desired offset value.

For example, if you rotate the JOG dial on the seconds digit up 59, turning the dial further will increase the number on the digit of minute by one.

To cancel the operation, or to restore the setting obtained prior to the EXECUTE/YES key press, press the STOP button or the EXIT/NO key. Each time you press one of these keys, the recorder returns to the previous hierarchy level of the menu, and finally exits SETUP mode and displays the previous Time Base.

4. Press the EXECUTE/YES key.

The selected offset value is stored and the display returns to the indication with the flashing [?] that appeared in step 2.

<Note>
For example, if you set MTC Offset mode to [ABS] (see the next section) and you wish to start the song from MTC's 01h 00m 00s 00f, you may wish to set a preroll of three seconds with an MTC offset of 00h 59m 57s 00f.

Setting Offset mode ("Offset Mode ?" menu)

If you have selected [MTC] in the "Setting Offset mode" menu, you need to select MTC Offset mode. This menu enables you to determine whether the specified MTC is output at ABS 00h 00m 00s 00f or at 001bar 1beat 00clk (bar/beat) of the Tempo Map.

<Notes>

- * As an example, if you set MTC Offset mode to [ABS] and you wish to start the song from MTC's 1h 00m 00s 00f, you may want to set a preroll of three seconds with MTC offset of 00h 59m 57s 00f. If you select [BAR] as the MTC Offset mode, a preroll of two measures is automatically set. Use 01h 00m 00s 00f; do not set a preroll value.
- * If you set Offset mode to [BAR] and use MTC to synchronize sequence software on the computer, the tempo of the sequencer may sometimes slip gradually. This is because the tempo of the recorder and the tempo of the software are slightly different even if both use the same tempo. Some sequence software can read the tempo output from the recorder correctly. We recommend that you use the tempo of the recorder on the sequence software. No such problems will occur if the sequence software synchronizes the recorder via MIDI clock, instead of MTC.

- Initial setting: [ABS]
- Offset mode option: [ABS], or [Bar]]
- * You can set the mode for each Program individually.
- * The settings can be saved and loaded as part of the song data.
- * The settings are maintained after you turn off the power to the recorder.

Setting MTC Offset mode

1. While the recorder is stopped, press the SETUP key to enter SETUP mode.

2. Turn the JOG dial to select [Offset Mode (?)] ([?] flashes.), then press the EXECUTE/YES key.

The current offset mode appears on the display. Pressing the EXECUTE/YES key to turn off the flashing [?] character. The Offset mode indicator flashes. With the initial setting, [ABS] flashes as shown below.

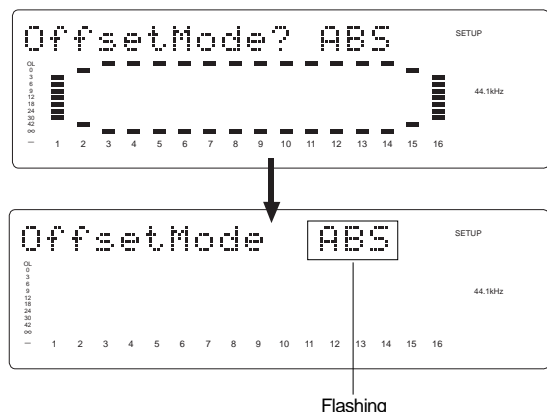

3. Use the JOG dial to select the desired Offset mode.

Rotating the JOG dial clockwise or counter-clockwise will alternately show a flashing [ABS] and [Bar]. If you select [ABS], the specified MTC offset time is output at ABS 00h 00m 00s 00f. If you select [Bar], the specified MTC offset time is output at 001bar 1beat 00clk of the Tempo Map.

4. Press the EXECUTE/YES key.

The selected offset mode is stored and the display returns to the indication with flashing [?].

To cancel the operation, or to restore the setting obtained prior to the EXECUTE/YES key press, press the STOP button or the EXIT/NO key. Each time you press one of these keys, the recorder returns to the previous hierarchy level of the menu, and finally exits SETUP mode and displays the previous Time Base.

Setting the Slave type (“Slave Type ?” menu)

The “Setting the Slave type” menu enables you to setup how recorder should function after chase lock, when recorder is set to sync externally in “slave mode ON” by the previously mentioned “Setting the slave mode.”

- Initial setting: [Vari]
 - Option: [Vari], [Free]
- [Vari]: The recorder synchronizes only to external MTC.
 [Free]: The recorder locks to MTC, then synchronizes to the internal clock.
- * You can set the parameter for each Program individually.
 - * The settings can be saved and loaded as part of the song data.
 - * The settings are maintained after you turn off the power to the recorder.
 - * The Program is automatically checked before the operation.
 - * The sampling rate is automatically checked before the operation.

Setting the Slave type

1. While the recorder is stopped, press the SETUP key to enter SETUP mode.

2. Turn the JOG dial to select [Slave Type ?] ([?] flashes.), then press the EXECUTE/YES key.
 The current Slave type appears on the display. Pressing the EXECUTE/YES key turns off the flashing [?] character, and the Slave type indicator flashes. With the initial setting, [Vari] flashes as shown below.

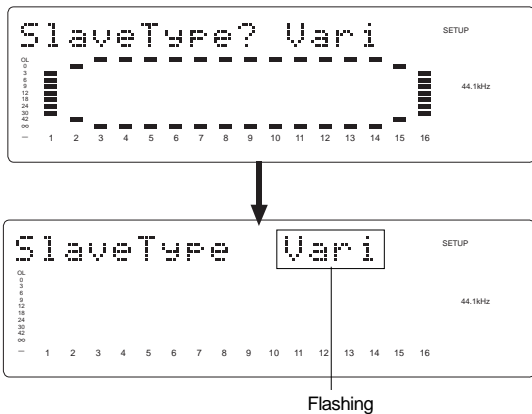

3. Use the JOG dial to select the desired Slave type.
 Rotating the JOG dial clockwise and counter-clockwise will cause the [Vari] and [Free] indicators to flash in sequence.

- <Notes>**
- You need to input MTC from an external device to the recorder with any Slave type.
 - The recorder re-chase window is fixed to ten frames. That is, if an offset between the master device and slave device exceeds ten frames, the recorder interprets that as out of sync, and tries to chase and lock to MTC sent from the master device. (This operation is called “re-chasing.”) During the re-chase operation, audio output is muted. If the slave machine slips with MTC from the master device by less than ten frames, the slave machine continues running while recognizing the slippage.
 - When you set the Slave type, the Vari Pitch function is automatically disabled. (The [VARI PITCH] indicator turns off.)

4. Press the EXECUTE/YES key.
 The selected Slave type is stored, and [?] flashes.

To cancel the operation, or to restore the setting obtained prior to the EXECUTE/YES key press, press the STOP button or the EXIT/NO key. Each time you press one of these keys, the recorder returns to the previous hierarchy level of the menu, and finally exits SETUP mode and displays the previous Time Base.

Setting the Record Protect function (“Rec Protect ?” menu)

The recorder features the Record Protect function, which is similar to the function of record-protect tabs on cassette tapes. The “Setting the Record Protect function” menu allows you to turn the Record Protect function on and off.

When this function is turned on, you cannot record, paste, or erase data. Use this function to protect your precious data from being erased accidentally.

- Initial setting: [Off]
 - Option: [Off] or [On]
- * You can turn the function on and off for each Program individually.
 - * The settings can be saved and loaded as part of the song data.
 - * The settings are maintained after you turn off the power to the recorder.
 - * The Program is automatically checked before the operation.

Recording enabled/disabled

1. While the recorder is stopped, press the **SETUP** key to enter **SETUP** mode.

2. Turn the **JOG** dial to select **[Rec Protect ?] ([?]** flashes), then press the **EXECUTE/YES** key.

The current setting appears on the display. Pressing the **EXECUTE/YES** key turns off the flashing [?] character, and the recording enabled/disabled indicator flashes. With the initial setting, [Off] flashes as shown below.

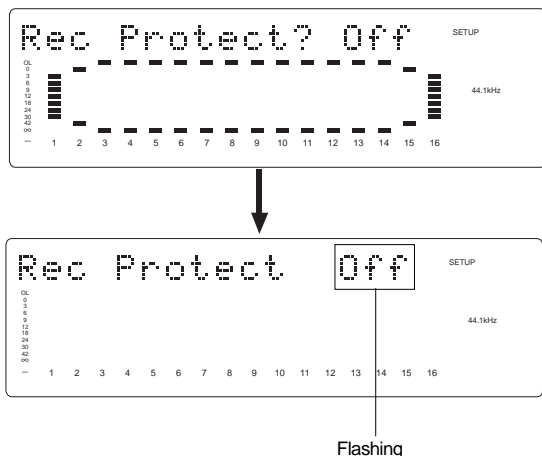

3. Use the **JOG** dial to enable or disable recording.

Rotating the **JOG** dial clockwise and counter-clockwise will flash [On] and [Off] alternately.

Selecting [Off] enables recording; you can record, paste, and erase data.

Selecting [On] disables recording; and you cannot record, paste, or erase data.

<Note>

When recording is disabled (On) and you try to record, paste, or erase data, the recorder displays [Protected] for a second, indicating that you cannot perform the operation. To perform the operation, you need to enable recording (Off).

4. Press the **EXECUTE/YES** key.

To cancel the operation, or to restore the setting obtained prior to the **EXECUTE/YES** key press, press the **STOP** button or the **EXIT/NO** key. Each time you press one of these keys, the recorder returns to the previous hierarchy level of the menu, and finally exits **SETUP** mode and displays the previous **Time Base**.

Setting digital input (“D. in ?” menu)

In the “Setting a digital input” menu, the signal to be input to the **DIGITAL/DATA IN** connector of the recorder can be set for either digital signals (adat digital signal or S/P DIF digital signal) or analog signals, and also setup of the digital in clock (synchronous or asynchronous).

By using this function, signals from external digital equipment (CD, MD, DAT, adat digital mixer) can be digitally recorded. If “SP DIF” is selected, the S/P DIF L, R signals input to **DIGITAL/DATA IN 1-8** will be assigned to tracks 1 and 2, and if “adat” is selected, adat signals input to **DIGITAL/DATA IN 1-8** will be assigned to tracks 1-8 (In D1624, adat signals input to **DIGITAL/DATA IN 9-16** will go to tracks 9-16).

When selecting the clock, there are the Async and Sync modes; either should be selected depending on the application. If it is set to “Async mode,” the later explained [Clock Sel?] (Setting the operating clock) should be setup in accordance to the application.

- Initial setting: Analog
- Assignable digital signal/setting digital in-clock:
 - adat: Async (adat digital signal/Asynchronous mode)
 - adat: Sync (adat digital signal/Synchronous mode)
 - SPDIF: Async (S/P DIF digital signal/Asynchronous mode)
 - SPDIF: Sync (S/P DIF digital signal/Synchronous mode)
 - Analog (not assigned digital signal)

- * This setting is shared by all Programs in the same disk.
- * The settings cannot be saved and loaded as part of the song data.
- * The settings are maintained after you turn off the power to the recorder.

<When using the D824>

Connect the **DIGITAL/DATA IN 1-8** terminal to the **OPTICAL OUT** (or **adat OUT**) terminal of the digital device. If you select [SPDIF: Async] or [SPDIF: Sync] for the digital input, Inputs 1-8 are assigned to track 1 and 2. If you select [adat: Async] or [adat: Sync] for the digital input, Inputs 1-8 are assigned to tracks 1-8 respectively.

<When using the D1624>

To input an S/P DIF digital signal to the D1624, use the **DIGITAL/DATA IN 1-8** terminal. To input adat digital signal, use the **DIGITAL/DATA 1-8** or **9-16** terminal. If you select [SPDIF: Async] or [SPDIF: Sync] for the digital input, Inputs 1-8 are assigned to tracks 1 and 2. If you select [adat: Async] or [adat: Sync] for the digital input, Inputs 1-8 are assigned to tracks 1-8 and Inputs 9-16 are assigned to tracks 9-16 respectively.

Setting digital input

1. While the recorder is stopped, press the SETUP key to enter SETUP mode.

2. Turn the JOG dial to select [D. in ?] ([?] flashes), then press the EXECUTE/YES key.

When [D. in?] ([?] flashes) is selected, the presently set digital input content will be shown. The flashing [?] is extinguished when the EXECUTE/YES key is pressed and the digital input setting will change from lighting to flashing. In the initial setting, [Analog] will flash as shown below.

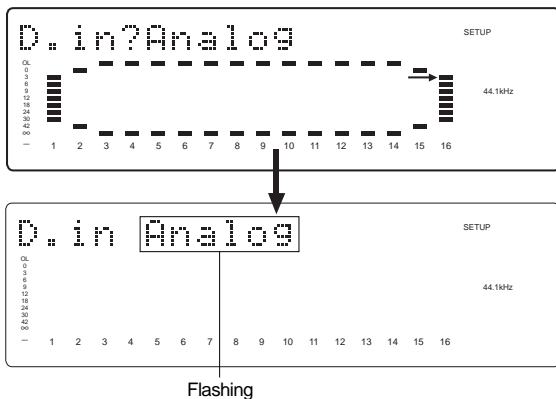

3. Select the desired digital signal and digital-in clock with the JOG dial.

In addition to [Analog], [adat: Async], [adat: Sync], [SPDIF: Async] or [SPDIF: Sync] can be selected.

[Async]/[Sync] which is displayed together with the digital signal (S/P DIF or adat) must be selected to whether the system is to be synchronized or not with the digital-in clock.

If you do not wish to synchronize the system with digital in, select [Async] and, if it is to be synchronized, select [Sync].

4. After selecting, press the EXECUTE/YES key again.

The selected digital signal is registered and [?] in Step-2 will return to flashing. When the digital input is setup and the correct digital signal is input, [DIGITAL] will light up in the display. If set to synchronous mode of [adat: Sync] or [SPDIF: Sync] and locked to the external digital signal, [EXT SYNC] will simultaneously light up.

To cancel the operation, or to restore the setting obtained prior to the EXECUTE/YES key press, press the STOP button or the EXIT/NO key. Each time you press one of these keys, the recorder returns to the previous hierarchy level of the menu, and finally exits SETUP mode and displays the previous Time Base.

<Notes>

- * Should [DIGITAL] flash in the display, check the connecting cable between the external equipment and the external equipment setting.
- * For the D1624, if the digital input is set to [adat] (Async or Sync), and if either one of the two DIGITAL/DATA INPUT (1-8, 9-16) becomes locked, [DIGITAL] will be lit in the display. In such a case, the track not locked will automatically be analog input. By using this function, 16 track simultaneous recording can be done by input of analog signals to tracks 1-8 and adat signals to tracks 9-16.

Setting digital output (“D. out ?” menu)

By using the “Setting a digital output” menu, the type of digital signal to be output to external digital equipment from the DIGITAL/DATA OUT connector (1-8 in D824, 1-8 and 9-16 in D1624) of this recorder, can be setup. Also, by using this function, sound recorded in this recorder can be sent to external digital equipment (MD, DAT, adat, digital mixer) in direct digital signals.

- Initial setting: adat
- Assignable digital signal: adat (adat digital signal)
SPDIF (S/P DIF digital signal)
- * This setting is shared by all Programs in the same disk.
- * The settings cannot be saved and loaded as part of the song data.
- * The settings are maintained after you turn off the power to the recorder.

<When using the D824>

Connect the DIGITAL/DATA OUT 1-8 terminal to the OPTICAL IN (or adat IN) terminal of the digital device. If you select [SPDIF] for the digital output, the outputs of tracks 1 and 2 are assigned to OUTPUT 1-8. If you select [adat] for the digital output, the output of track 1-8 are assigned.

<When using the D1624>

To connect the D1624 with a digital device, to output an S/P DIF digital signal, or to output an adat digital signal, use the DIGITAL/DATA IN 1-8 or 9-16 terminal. If you select [SPDIF] for the digital output tracks, the outputs of tracks 1 and 2 are assigned to OUTPUT 1-8 and the outputs of tracks 3 and 4 are assigned to OUTPUT 9-16. If you select [adat] for the digital output, the outputs of tracks 1-8 are assigned to OUTPUT 1-8 and the outputs of tracks 9-16 to OUTPUT 9-16.

Setting digital output

1. While the recorder is stopped, press the SETUP key to enter SETUP mode.

2. Turn the JOG dial to select [D. out ?] ([?] flashes), then press the EXECUTE/YES key.

The current digital output signal appears on the display. Pressing the EXECUTE/YES key turns off the flashing [?] character, and setting of the digital output signal flashes. With the initial setting, [adat] flashes as shown below.

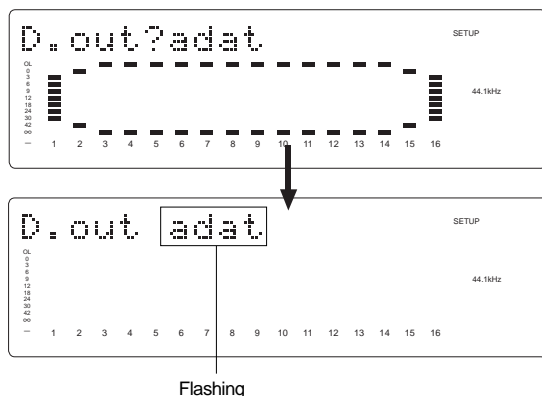

3. While the [adat] is flashing, turn the JOG dial.

[SPDIF] can be selected in addition to [adat]. Select [adat] if the adat digital signal (8 tracks) is to be output, and [SPDIF] if the S/P DIF digital signal (2 tracks) is to be output.

4. After selecting the digital output signal, press the EXECUTE/YES key.

The selected digital output signal will be registered and the flashing [?] in Step-2 will return to flashing.

To cancel the operation, or to restore the setting obtained prior to the EXECUTE/YES key press, press the STOP button or the EXIT/NO key. Each time you press one of these keys, the recorder returns to the previous hierarchy level of the menu, and finally exits SETUP mode and displays the previous Time Base.

Setting BAR/BEAT resolution mode (“Resolution ?” menu)

The “Setting BAR/BEAT resolution mode” menu enables you to turn BAR/BEAT resolution mode on and off. The initial setting is “Off.” When you turn this mode on, the CLK (clock) digits will be always round off to 00 and be stored in the memory key while the recorder is using the BAR/BEAT/CLK Time Base. That is, beat resolution is used. Using this function allows you to automatically store a beat-resolution value of the CLIPBOARD IN/OUT points and other points in real-time. (Press the STORE key, then the corresponding memory key while playing the recorder.) Therefore, it is very convenient when you perform the Copy & Paste or Move & Paste operation in beat-resolution.

For example, assume that you have stored the value for 001bar 1 ♪ 46 clk as the CLIPBOARD IN point, and the value for 002bar 4 ♪ 51 clk as the CLIPBOARD OUT point. These values will be used as they are if BAR/BEAT resolution mode is turned off. However, the mode is turned on, the following values will be stored instead. The following example has a time signature setting of 4/4.

001bar 1 ♪ 46 clk -> 001bar 1 ♪ 00 clk (A clk value of 46 will be rounded off.)

002bar 4 ♪ 51 clk -> 003bar 1 ♪ 00 clk (A clk value of 51 will be rounded up.)

- Initial setting: [Off]
- Options: [On] or [Off]
- * This setting is shared by all Programs in the same disk.
- * The settings cannot be saved and loaded as part of the song data.
- * The settings are maintained after you turn off the power to the recorder.

Setting BAR/BEAT resolution mode

1. While the recorder is stopped, press the **SETUP** key to enter **SETUP** mode.

2. Turn the **JOG** dial to select [**Resolution ?**] ([?] flashes), then press the **EXECUTE/YES** key.

The current BAR/BEAT resolution mode setting appears on the display.

Pressing the **EXECUTE/YES** key turns off the flashing [?] character, and the BAR/BEAT resolution mode setting flashes. With the initial setting, [Off] flashes as shown below.

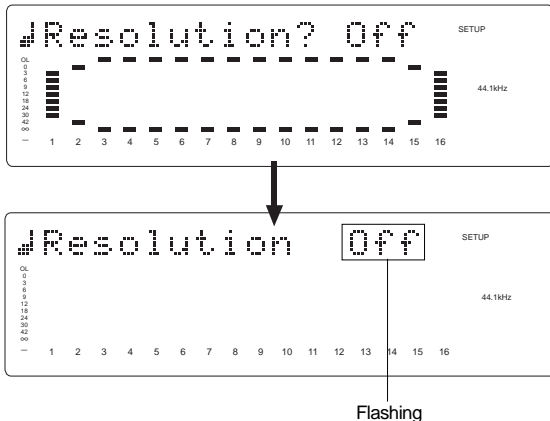

3. Use the **JOG** dial to turn the mode [**On**] or [**Off**].

When you turn the **JOG** dial clockwise and counter-clockwise, [On] and [Off] flash alternately.

Selecting [On] turns BAR/BEAT resolution mode on, and selecting [Off] turns BAR/BEAT resolution mode off.

4. Press the **EXECUTE/YES** key.

The selected mode setting is stored, and [?] flashes.

To cancel the operation, or to restore the setting obtained prior to the EXECUTE/YES key press, press the STOP button or the EXIT/NO key. Each time you press one of these keys, the recorder returns to the previous hierarchy level of the menu, and finally exits SETUP mode and displays the previous Time Base.

Setting the MIDI device number (“Device ID ?” menu)

The “Setting the MIDI device number” menu enables you to set the recorder device ID number required to control the unit from a sequence software using MMC (MIDI Machine Control) or FEX (Fostex System Exclusive Message).

The transmit device ID links to this setting. You can set the device ID from 00 to 99.

However, if the device ID number of the message the recorder receives is [7F], the recorder will recognize it to perform the corresponding operation, regardless of its device ID setting.

- Initial setting: [00]
- Device ID: [00] ~ [99]
- * This setting is shared by all Programs in the same disk.
- * The settings cannot be saved and loaded as part of the song data.
- * The settings are maintained after you turn off the power to the recorder.

Setting the MIDI device ID

1. While the recorder is stopped, press the **SETUP** key to enter **SETUP** mode.

2. Turn the **JOG** dial to select [**Device ID?**] ([?] flashes), then press the **EXECUTE/YES** key.

The current MIDI device ID number appears on the display. Pressing the **EXECUTE/YES** key turns off the flashing [?] character, and the MIDI device ID number flashes. With the initial setting, [00] flashes as shown below.

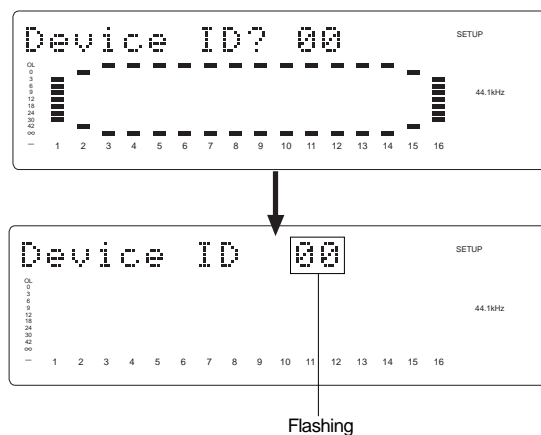

3. Use the JOG dial to set the desired MIDI device ID number.

Turning the JOG dial clockwise increments the value, and turning it counter-clockwise decrements the value.

4. Press the EXECUTE/YES key.

The MIDI device ID number is stored, and [?] flashes.

To cancel the operation, or to restore the setting obtained prior to the EXECUTE/YES key press, press the STOP button or the EXIT/NO key. Each time you press one of these keys, the recorder returns to the previous hierarchy level of the menu, and finally exits SETUP mode and displays the previous Time Base.

Setting the Operating Clock (“Clock Sel ?” menu)

The “Setting the Operating Clock” menu is used to setup the operating clock of the recorder. If digital input is set to asynchronous mode of [adat: Async] or [SPDIF: Async] in the previous [D. in?] (Digital input setting), whether this recorder is to operated by its internal clock or synchronized to the word clock signal from the external digital equipment should be selected when recording in digital from external digital equipment (DAT, adat, CD, MD, etc.). The initial setting is set to synchronize to the internal clock. The setup item [Video] is effective if an optional Model 8345 TC/SYNC card is installed. For details, refer to the “APPENDIX.”

- Initial setting: [Int.]
 - Device ID: [Int.] (Internal clock)
[Auto]
[Word]
[Video] (Tis item will be effective if the optional Model 8345 TC/SYNC card is installed in this recorder.)
- * This setting is shared by all Programs in the same disk.
* The settings cannot be saved and loaded as part of the song data.
* The settings are maintained after you turn off the power to the recorder.

Setting the operating clock

1. While the recorder is stopped, press the SETUP key to enter SETUP mode.

2. Turn the JOG dial to select [Clock Sel ?] ([?] flashes), then press the EXECUTE/YES key.

A flashing [?] will extinguish by pressing the EXECUTE/YES key and the operating clock information that was lit will being flashing. Initial setting, it will show “Int.”

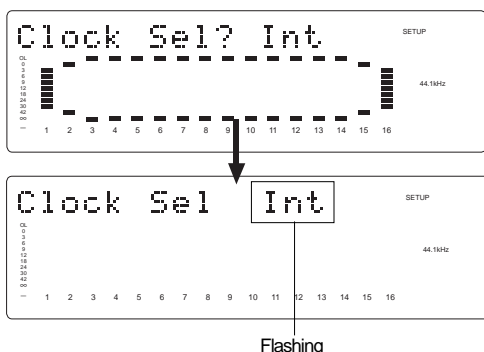

3. With the JOG dial, select the operating clock.

If [Int.] (initial setting) is selected, the recorder will operate using the internal clock.
If [Auto] is selected, the recorder will sync to an external digital signal.
If [Word] is selected, the recorder will sync to an external word clock signal.

4. Press the EXECUTE/YES key.

The selected operating clock will register and [?] in step-2 above, will flashes.

Refer to the chart of next page in regards to “Digital input setting” and “Operating clock setting.”

To cancel the operation, or to restore the setting obtained prior to the EXECUTE/YES key press, press the STOP button or the EXIT/NO key. Each time you press one of these keys, the recorder returns to the previous hierarchy level of the menu, and finally exits SETUP mode and displays the previous Time Base.

[Clock Sel ?] setting		Int	Auto	Word	Video
SPDIF :Async	clock received from WORD IN	Regardless of receiving or not receiving word clock from WORD IN, the recorder is referenced to the internal clock. When the recorder receives correct digital signals, the [DIGITAL] indicator lights in the display.	When receiving word clock from WORD IN, the recorder automatically synchronizes to the incoming clock, while the [DIGITAL] and [EXT SYNC] indicators light in the display.	When receiving word clock from WORD IN, the recorder synchronizes to the incoming clock, while the [DIGITAL] and [EXT SYNC] indicators light in the display.	Available only when installing the optional Model 8345 TC/SYNC card. If you try to select "Video," [Void w/o Video] is displayed and you cannot select it. See the appendix of the Reference manual for details.
	no clock received from WORD IN		When no word clock is received, the recorder is referenced to the internal clock, while the [EXT SYNC] indicator flashes.	When no word clock is received, the [EXT SYNC] indicator flashes showing that the recorder cannot be locked.	
SPDIF :Sync	clock received from WORD IN	Regardless of receiving or not receiving word clock from WORD IN, the recorder synchronizes to the external S/P DIF digital signal. When the recorder receives correct digital signals, the [DIGITAL] and [EXT SYNC] indicators light in the display. When Digital In is set to a SYNC mode, if you try to select [Clock Sel?] menu, The display will show [Clock Sel D.in!] (indicating that the clock is set to Digital In!) and the recorder ignores your operation.			
	no clock received from WORD IN				
adat :Async	clock received from WORD IN	Regardless of receiving or not receiving word clock from WORD IN, the recorder is referenced to the internal clock. When the recorder receives correct digital signals, the [DIGITAL] indicator lights in the display.	When receiving word clock from WORD IN, the recorder automatically synchronizes to the incoming clock, while the [DIGITAL] and [EXT SYNC] indicators light in the display.	When receiving word clock from WORD IN, the recorder synchronizes to the incoming clock, while the [DIGITAL] and [EXT SYNC] indicators light in the display.	
	no clock received from WORD IN		When no word clock is received, the recorder is referenced to the internal clock, while the [EXT SYNC] indicator flashes.	When no word clock is received, the [EXT SYNC] indicator flashes showing that the recorder cannot be locked.	
adat :Sync	clock received from WORD IN	Regardless of receiving or not receiving word clock from WORD IN, the recorder synchronizes to the external adat digital signals. When the recorder receives correct digital signals, the [DIGITAL] and [EXT SYNC] indicators light in the display. When Digital In is set to a SYNC mode, if you try to select [Clock Sel?] menu, The display will show [Clock Sel D.in!] (indicating that the clock is set to Digital In!) and the recorder ignores your operation.			
	no clock received from WORD IN				

Checking the number of track events ("NOs Event ?" menu)

The "Checking the number of track events" menu enables you to check the number of events on each track. Each track (including Additional tracks) of recorder Programs consists of consecutive audio files (and "zero" files). The number of events represents the total number of audio files and 0 files. Each track can contain up to 512 events.

If you are editing a song of typical length (about six minutes), repeated editing operation does not usually cause this maximum number to be exceeded. (Exceeding this limit is called "event number overflow.") Even a 20-minute song will not cause event number overflow. This is because the recorder system always optimizes the data structure by keeping the number of events low. However, if a recording on a track is scattered in different areas of the disk, or if you have made a very long recording on a single track and performed many edits, you should be wary of "event number overflow." To avoid this problem, use the "Checking the number of track events" menu to check the number of events on each track prior to recording or editing.

Checking the number of track events

1. While the recorder is stopped, press the **SETUP** key to enter **SETUP** mode.
2. Turn the **JOG** dial to select **[NOs Event?]** ([?] flashes), and then press the **EXECUTE/YES** key. The screen changes as follows, indicating the number of events on track 1. (In this example, track 1 includes five events.)

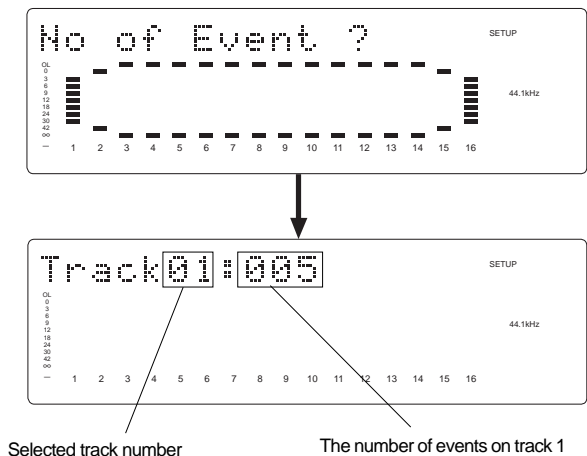

3. Use the JOG dial to select another (01-24) to check the number of events on the corresponding track.
4. Press the EXIT/NO key or the STOP button repeatedly to exit SETUP mode.

To cancel the operation, or to restore the setting obtained prior to the EXECUTE/YES key press, press the STOP button or the EXIT/NO key. Each time you press one of these keys, the recorder returns to the previous hierarchy level of the menu, and finally exits SETUP mode and displays the previous Time Base.

* For more information on audio files and events, refer to the "Audio file and event" section of the "Before Starting" chapter.

Drive Format Information ("Drive Info?" menu)

Format information of the current drive presently installed can be checked by using the "Drive Format Information" menu. Should any trouble occur in the recorder, providing the information obtained here to our nearest Fostex Service Station will be of great help in giving quick service. The following items will be displayed and can be confirmed.

1. Manufacture / Model of the currently installed hard disk.
2. Format method
3. Last day of formatting in standard type
4. Format type
5. Simultaneously recordable number of tracks
6. Number of bits at formatting
7. Sampling frequency at formatting
8. Present number of programs
9. Present number of free blocks
10. Audio file / maximum number of events and its program No.
11. Maximum number of events of the time code and its program number
12. Specific capacity of the drive
13. Remaining capacity of the drive
14. Present software version
15. Present multiple undo function mode on/off

Checking method of the format information

1. While the recorder is stopped, press the SETUP key to enter SETUP mode.
2. Turn the JOG dial to select [Drive Info?] ([?] flashes), and then press the EXECUTE/YES key. First, the manufacturer / model of the currently installed hard disk will scroll and displayed.

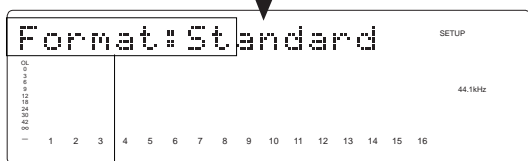
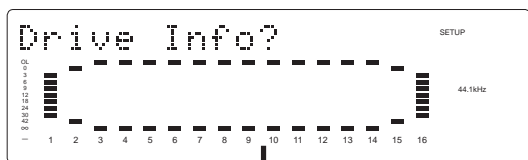

Scrolled and displayed

3. As the JOG dial is rotated, information is displayed one after the other (See display examples).

- * This indicates that the formatting method is standard. In addition to [Standard] formatting method, [Quick] or [Erase] will be displayed.



- * The last date in when it was formatted in standard will be displayed. The disk formatted by [Quick] will be displayed as [-, -, '-].

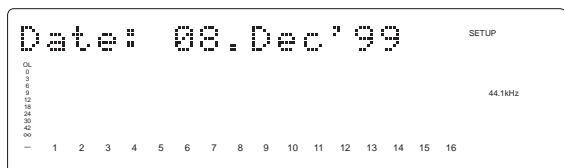

- * **This indicates that the format type was linear.**
In addition to [Linear], the display can also show [Backup], [LP], [ADAC] or [Illegal FM].



- * **This indicates that simultaneous recordable number of tracks is 16.**
In addition to [16 Trk], the display can also show [8 Trk], [4 Trk] or [24 Trk].



- * **This indicates that the recorder is formatted in 24 bits.**
In addition to [24], the display can also show [16] and [12].



- * **This indicates that it is formatted in FS=44.1kHz.**
In addition to [44.1 kHz], the display can also show [48 kHz], [96 kHz] or [32 kHz].



- * **This indicates that three programs exist.**

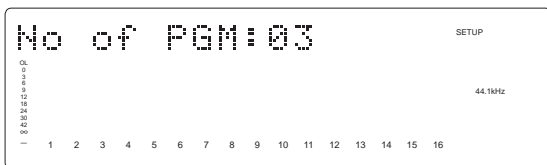

- * **This indicates that the number of free blocks are five.**

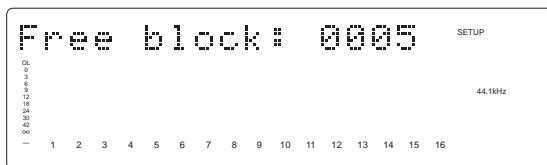

- * **This indicates that the maximum figure is 5 for the number of audio file / event and that this program is PGM01.**



- * **This indicates that the specific capacity of this drive is 2112MB.**

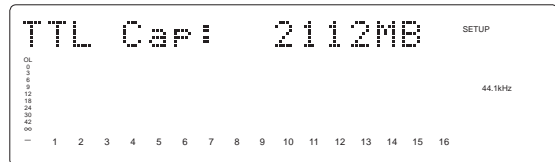

- * **This indicates that the remaining capacity (REMAIN) of the drive is 1618MB.**

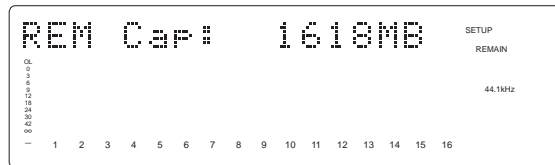

- * **This indicates that the figure is "0" for the time code number of events and that program is PGM01.**

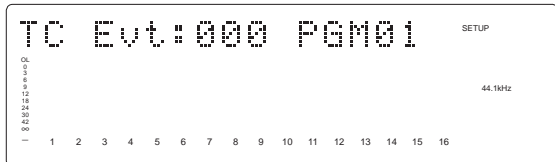

- * **Version number of the software in this recorder will be displayed.**
The display below indicates that the recorder you are using is the D1624 and the software version number is 1.0.

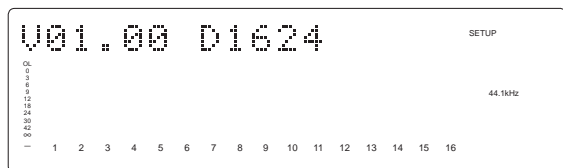

- * **The ON/OFF switching of multiple undo function set at format of the current drive will be displayed.**
The display below indicates that the multiple undo function of the current drive presently in use is ON.



Drive Setting (“Drive Sel?” menu)

In this “Drive Setting,” a switch is made between the current drive (E-IDE hard disk) and the backup drive (Removable SCSI drive).

<Note>
The following operations cannot be executed when the drive is switched to “backup drive.”

- * Save/load of song data * Setup of rhythm * Recording * Creating a new program * Deleting a program
- * Copy & paste and Move & paste * Erase * Track exchange * Multiple undo * Setup of tempo
- * ON/OFF of metronome function * Setup of permission or denial of recording

*If power to this recorder is switched again, the drive will automatically switch to current drive (E-IDE).
 In order to take out the removable disk when set to backup drive, press the EXIT/NO key while holding down the SHIFT key.*

Setting of the drive

1. While the recorder is stopped, press the **SETUP** key to enter **SETUP** mode.
2. Turn the **JOG** dial to select **[Drive Sel?] ([?)** flashes), and then press the **EXECUTE/YES** key. The current setting will start flashing which indicates it is ready to change setting. In the case of initial setting it will show “IDE.”

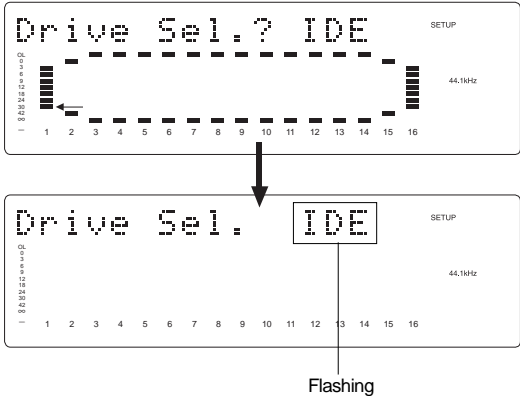

3. With the **JOG** dial, choose either “IDE” or “SCSI 6” you want.

4. Press the **EXECUTE/YES** key after choosing the setting you want. The display will be as follows depending on the selected drive.

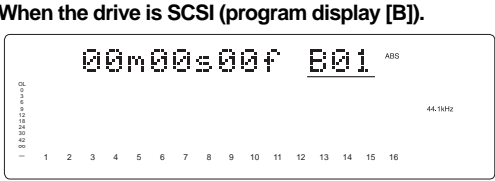

To cancel the operation, or to restore the setting obtained prior to the EXECUTE/YES key press, press the STOP button or the EXIT/NO key. Each time you press one of these keys, the recorder returns to the previous hierarchy level of the menu, and finally exits SETUP mode and displays the previous Time Base.

(Digital Recorder)
Model D824/D1624

MIDI Implementation Chart

Date:
Version: V1.00

Function.....	Transmitted	Recognized	Remarks
Basic Channel	Default Changed	× ×	
Mode	Default Message Altered	× × *****	
Note Number:	True voice	× *****	
Velocity	Note ON Note OFF	× ×	
After Touch	Key's Channel's	× ×	
Pitch Bend		×	
Control Change		×	
Program Change:	True #	× *****	
System Exclusive		○ (rem. 1) ○ (rem. 2)	
Common	: Quarter frame : Song Position : Song Select : Tune	○ ○ × ×	
System Real Time	: Clock : Commands	○ ○ (rem. 3)	
Aux. Message	: Local ON/OFF : All Notes OFF : Active Sense : Reset	× × × ×	
Notes	rem. 1: MMC (Device ID=00~99, 127), MTC, Identity reply, FOSTEX Exclusive rem. 2: MMC (Device ID=00~99, 127), MTC, Inquiry, FOSTEX Exclusive rem. 3: START, STOP, CONTINUE		

Mode 1: OMNI ON, POLY
Mode 3: OMNI OFF, POLY

Mode 2: OMNI ON, MONO
Mode 4: OMNI OFF, MONO

○ : Yes
× : No

MMC Command List

Command List	Movement (Recorder)
01: STOP	STOP
02: PLAY	PLAY
03: DEFERRED PLAY	DEFERRED PLAY
04: FAST FORWARD	F FWD
05: REWIND	REWIND
06: RECORD STROBE	REC
07: RECORD EXIT	PUNCH OUT
09: PAUSE	STOP
40: WRITE	Refer to MMC Response/Information Field List
41: MASKED WRITE	Refer to MMC Response/Information Field List
42: READ	Refer to MMC Response/Information Field List
44: LOCATE	LOCATE to Setting Data
46: SEARCH	CUE/REVIEW (+/- 1~60 times)
47: SHUTTLE	CUE/REVIEW (+/- 1~60 times)
4C: MOVE	Refer to MMC Response/Information Field List
4D: ADD	Refer to MMC Response/Information Field List
4E: SUBTRACT	Refer to MMC Response/Information Field List

MMC Response/Information Field List	Command
01: SELECTED TIME CODE	READ/WRITE/MOVE/ADD/SUBTRACT
03: REQUESTED OFFSET	READ/WRITE
04: ACTUAL OFFSET	READ
08: GP 0	READ/WRITE/MOVE/ADD/SUBTRACT
09: GP 1	READ/WRITE/MOVE/ADD/SUBTRACT
0A: GP 2	READ/WRITE/MOVE/ADD/SUBTRACT
0B: GP 3	READ/WRITE/MOVE/ADD/SUBTRACT
0C: GP 4	READ/WRITE/MOVE/ADD/SUBTRACT
0D: GP 5	READ/WRITE/MOVE/ADD/SUBTRACT
0E: GP 6	READ/WRITE/MOVE/ADD/SUBTRACT
0F: GP 7	READ/WRITE/MOVE/ADD/SUBTRACT
48: MOTION CONTROL TALLY	READ
4C: RECORD MODE	READ/WRITE
4E: TRACK RECORD STATUS	READ
4F: TRACK RECORD READY	READ/WRITE/MASKED WRITE
51: RECORD MONITOR	READ/WRITE

Inquiry Message List

IDENTITY REQUEST: F0, 7E, <channel>, 06, 01, F7
 IDENTITY REPLY: F0, 7E, <channel>, 06, 02, 51, 01, 00, 0*, 00, **, **, **, **, F7

51: Fostex ID
 01, 00: Device family code
 0*, 00: Device family number D824 or D1624 (10=D824, 11=D1624)
 **, **, **, **: Software version

Fostex MIDI System Exclusive Message Format for D824/D1624

<Note>

Following protocol is effective only in equipment which will reply by -

Identity Reply=F0 7E<channel>06 02 51 01 00 10 00 ** ** ** ** F7 (D824)

Identity Reply=F0 7E<channel>06 02 51 01 00 11 00 ** ** ** ** F7 (D1624)

against the Inquiry Message=F0 7E<channel>06 01.

Fostex System Exclusive Message

General Structure=F0 51<device id><sub id 1>(<data>)F7

* Numbers are all expressed in hexadecimal units.

Table: <sub id 1> (<data>)

Command or Model Set Controller to D824/D1624	Acknowledge or Status D824/D1624 to Controller
Loop on/off 12 22 (<on/off>)	
Post locate 12 28 (<post locate mode>)	
Auto rec 12 2D (<on/off>)	32 2D (<edit message>)
Lock enable 12 41 (<lock enable>)	
Lock mode 12 42 (<lock mode>)	
Copy clip 12 45 (<count><mmc track>)	32 45 (<edit message>)
Copy paste 12 46 (<count=01><repeat count>) or 12 46 (<count><repeat count><mmc track>)	32 46 (<edit message>)
Erase 12 47 (<count><mmc track>)	32 47 (<edit message>)
Clipboard play 12 49	32 49 (<edit message><mmc track>)
Undo 12 4A	32 4A (<edit message>)
Redo 12 4B	32 4B (<edit message>)
Move clip 12 4D (<count><mmc track>)	32 4D (<edit message>)
Move paste 12 4E (<count=01><repeat count>) or 12 4E (<count><repeat count><mmc track>)	32 4E (<edit message>)
Move clip 12 4D (<count><mmc track>)	32 4D (<edit message>)
Move clip 12 4D (<count><mmc track>)	32 4D (<edit message>)
Move clip 12 4D (<count><mmc track>)	32 4D (<edit message>)
Move clip 12 4D (<count><mmc track>)	32 4D (<edit message>)
Digital in ch. 13 41 (<channel><channel><sync/async>)	
Digital out ch. 13 42 (<channel><channel>) * Refer to Note.	
Move clip 12 4D (<count><mmc track>)	32 4D (<edit message>)
Program change 13 43 (<program>)	
Click on/off 13 44 (<on/off>)	
Resolution on/off 13 46 (<on/off>)	
Midi Sync out 13 47 (<nidi sync>)	
MTC offset mode 13 48 (<MTC offset mode>)	
Vari pitch 13 49 (<count=3><on/off><vari pitch>) or 13 49 (<count=1><on/off>)	
Signature set 14 01 (<signature map>)	34 00 (<edit message>)
Tempo set 14 02 (<tempo set map>)	34 00 (<edit message>)
Tempo map all erase 14 03	34 00 (<edit message>)
Preroll time set 14 04 (<mmc time>)	
Frame rate set 14 06 (<frame rate>)	
Time base set 14 08 (<time base>)	

Status Request

Status request command Controller to D824/D1624		Status reply D824/D1624 to controller
Loop op. status	22 21	32 21 (<Loop op. mode = 12>)
Loop status	22 22	32 22 (<on/off>)
Post locate status	22 28	32 28 (<post locate status>)
Auto rec status	22 2D	32 2D (<edit message>)
Lock status	22 41	32 41 (<lock status>)
Lock mode status	22 42	32 42 (<lock mode>)
Copy clip status	22 45	32 45 (<edit message=01 or =14>)
Copy paste status	22 46	32 46 (<edit message=02><mmc time>) or 32 46 (<edit message=00>)
Erase status	22 47	32 47 (<edit message=02><mmc time>) or 32 47 (edit message=00)
Nondes. mode	22 4C	32 4C (<on/off>)
Move clip status	22 4D	32 4D (<edit message=01 or =14>)
Move paste status	22 4E	32 4E (<edit message=02><mmc time>) or 32 4E (<edit message=00>)
Digital in ch. st.	23 41	33 41 (<channel><channel>)
Adat in status	23 41	33 41 (<channel=7F><count><mmc track>)
Digital out ch. st.	23 42	33 42 (<channel><channel>)
Adat out status	23 42	33 42 (<channel=7F><channel=0>)
Program status	23 43	33 43 (<program>)
Click status	23 44	33 44 (<on/off>)
Level status	23 45	33 45 (<count=10><level data>)
resolution status	23 46	33 46 (<on/off>)
midi sync out status	23 47	33 47 (<midi sync>)
MTC offset mode status	23 48	33 48 (<MTC offset mode>)
vari pitch status	23 49	33 49 (<count=3><on/off><vari pitch>)
signature map	24 01(<event number>)	34 01 (<signature map>)
tempo set map	24 02(<event number>)	34 02 (<tempo set map>)
preroll time	24 04	34 04 (<mmc time>)
remain time	24 05	34 05 (<mmc time>)
frame rate status	24 06	34 06 (<frame rate>)
time base status	24 08	34 08 (<time base>)

<Note 2>

There is a limitation on specifying the <channel><channel> setting. For details, refer to "Explanation on Command/Mode Set" mentioned in later pages.

<Allocation of GP0~GP7>

Edit point memory of this equipment is allotted to the response/information field of 08~0F (GP0~GP7) as shown below.

GP7 however, will be used as the work memory for small adjusting of the registered figure (Refer to Examples 4 and 5).

<Response/Information Field>

08 GP0 : locate memory	09 GP1 : clipboard in memory
0A GP2 : clipboard out memory	0B GP3 : start memory
0C GP4 : auto punch in memory	0D GP5 : auto punch out memory
0E GP6 : end memory	0F GP7 : reserved

[Example 1] <mmc time> is registered in the start memory (using the write command).

F0 7F <device ID> 06 <write = 40> <count> <GP3 = 0B> <mmc time> F7

[Example 2] Locate memory is recalled (using the read command).

F0 7F <device ID> 06 <read = 42> <count> <GP3 = 0B> <mmc time> F7

[Example 3] On-the-fly registering in the punch in memory (using the move command).

F0 7F <device ID> 06 <move = 4C> <count> <destination = 0C (GP4) > <source = selected time code = 01> F7

[Example 4] When + 1 frame is to be set in the punch in memory (using the add command).

* Time figure to be added is pre-registered in GP7 (Set 00h 00m 00s 01f in GP7).
F0 7F <device ID> 06 <add = 4D> <count> <destination = 0C (GP4)> <source #1 = 01 (GP4)> <source #2 = 0F (GP7)> F7

[Example 5] When -1 frame is to be set in the punch in memory (using the subtract command).

* Time figure to be subtracted is pre-registered in GP7 (Set 00h 00m 00s 01f in GP7).
F0 7F <device ID> 06 <subtract = 4E> <count> <destination = 0C (GP4)> <source#1 = 0C (GP4)> <source #2 = 0F (GP7)>F7

Data Type

<loop op.mode>	12=stop Indicates the next operating mode following locating to the start point (GP3) upon arriving at the end point (GP6) by the play mode. In D824/D1624, 12=stop only is effective.
<post locate mode>	12=stop 15=play Specifies operating mode in which D824/D1624 should enter upon completing the locate operation. Corresponds to the setting of AUTO PLAY ON ("15")/OFF ("12") on the main unit.
<count>	01~7F Specifies succeeding data byte numbers.
<mmc track>	Complies to the MMC (MIDI MACHINE CONTROL) standard track bit map. In D-108, you always need to specify two byte combinations of "r0" and "r1."
<edit message>	00 = no message 01 = completed (completion flag) 02 = active (execution flag) 02<mmc time> = Indicates unprocessed time by active (execution flag) and <mmc time>. 02<count><mmc track> = Indicates source track by active (execution flag) and <mmc track>. Used for clipboard play. 03 = cancel (execution stop) 05 = Indicates rehearsal (rehearsal mode of auto rec). Possible of undo. 06 = Indicates take (take mode of auto rec). Possible of undo. 10 = over value error 10 <mmc time> = Capacity shortage time is indicated by over value error (error by capacity shortage) and <mmc time>. In copy paste, it indicates capacity shortage time required for a minimum one time paste. 11 = Indicates in point error (incorrect in point). 12 = Indicates out point error (incorrect out point). 14 = Indicates void data (data necessary for paste does not exist). 18 = Indicates track select error (track necessary to execute copy/move or erase/cut is not correctly setup). 19<repeat count> = Indicates repeat number error and repeat numbers executable by <repeat count>. 1A = Indicates disable rec (record disable mode). 25 = Indicates can't undo rehearsal (rehearsal mode of auto rec). Impossible to undo. 26 = Indicates can't undo take (take mode of auto rec). Impossible to undo. 71 = Indicates on. 72 = Indicates off.
<mmc time> <on/off>	hr mn sc fr {ff/st} complies to the MMC standard time code. 70 = default 71 = on 72 = off
<repeat count>	01~7F Especially when executing commands such as paste, the number of pasting times to be continuously repeated following the auto punch in point is specified.
<channel>	00~24, 7F Select recorder tracks 1~24. "00" in particular, is not specified (default setting). "7F" indicates input/output of Adat optical. For details, refer to explanation on setting the Command/Mode.
<lock enable>	00 = lock disable, chase disable 01 = lock enable, chase enable Corresponds to SLAVE ON ("01")/OFF ("00") in the main unit.
<lock status>	00 = lock disable, chase disable 01 = lock enable (unlocked), chase enable (unlocked) 11 = lock enable (locked), chase enable (locked)
<program>	01~7F Indicates program numbers (P1~P99) on the main unit. However, D824/D1624 can specify only 01 (corresponds to P01) and 63H (corresponds to P99).
<lock mode>	40 = Free 42 = Vari Indicates the slave mode when this equipment is set to slave ON.

<signature map>	<p>bar2, bar1, bar0, sign, sigd bar2: The 100th digit of the bar figure is expressed in BCD. bar1: The 10th digit of the bar figure is expressed in BCD. bar0: The 1 digit of the bar figure is expressed in BCD. sign: Numerator of the signature to be set is expressed in BCD. sigd: Denominator of the signature to be set is expressed in BCD. When specified as sign=00 and sigd=00, signature data of that bar position will be deleted. Also, bar2=bar1=bar0=sign=sigd=00 indicates "no corresponding data" (such as when a figure specified by <event number> do not exist at receiving the signature map request).</p>
<tempo set map>	<p>bar2, bar1, bar0, beat, tmp2, tmp1, tmp0 bar2: The 100th digit of the bar figure is expressed in BCD. bar1: The 10th digit of the bar figure is expressed in BCD. bar0: The 1 digit of the bar figure is expressed in BCD. beat: The beat figure is expressed in BCD. tmp2: Numerator of the tempo to be set is expressed in BCD. tmp1: Denominator of the tempo to be set is expressed in BCD. tmp0: The 1 digit of the tempo is expressed in BCD. When specified as tmp2=tmp1=tmp0=00, tempo data of that bar and meter position will be deleted. Also, bar2=bar1=bar0=sign=sigd=00 indicates "no corresponding data" (such as when a figure specified by <event number> do not exist at receiving the signature map request).</p>
<event number>	<p>When one data registered by <signature map> and <tempo set map> is declared as one event, the number of events from head of the tune (the umpteenth event counted from head of the tune) must be specified. <event number="00"> is the first event.</p>
<midi sync>	<p>00: OFF 01: CLK (MIDI CLOCK) 02: MTC This corresponds to "MIDI SYNC OUT" of the SETUP menu.</p>
<vari pitch>	<p>Will be composed of two bytes (Q, P). Q: 0qqqqqqq (binary) -> <vari data> = "qqqqqqpppppppp" A 14 bit data of X0.1 P: 0qqqqqqq (binary) attached with a minus symbol. Vari-pitch must be specified, at +0.1% when MSB (q)=0 (Example: 0000000000001), and at -0.1% when MSB (q)=1 (Example: 1111111111111).</p>
<frame rate>	<p>00: 30nd 01: 29.97nd 02: 29.97df 03: 25 04: 24 05: 30df Corresponds to selecting "FRAME" of the SETUP menu.</p>
<MTC offset mode>	<p>00: ABS 01: signature Corresponds to selecting "MTC OFFSET MODE" of the SETUP menu.</p>
<time base>	<p>00: ABS 01: BAR BEAT 02: MTC Corresponds to selecting "TIME BASE SEL" of the SETUP menu.</p>
<level data>	<p>t1, t2 tn n: Indicates the track number. tn: Indicates absolute 8 bits of the Audio 16 bit data (Range: 00~7F).</p>

Explanation on the Command/Mode Set

12 22 (<on/off>): loop on/off command

The command for setting the "loop mode on/off" (=ON/OFF of AUTO RTN) of D824/D1624. Default figure of the loop operation mode is "12=stop" and this cannot be changed.

12 28 (<post locate mode>): post locate command

The command for setting the "post locate mode" (=ON/OFF of AUTO PLAY) of D824/D1624. It will stop after locating if "post locate mode=12." It will enter play after locating if "post locate mode=15."

12 2D (<on/off>): auto rec command

The command for setting "auto rec mode on/off" (=ON/OFF of AUTO PUNCH) of D824/D1624. Upon receiving this command, D-160 will immediately reply the operating condition by sending "32 2D (<edit message>)".

12 41 (<lock enable>): lock enable command

The command for setting "slave mode on/off" (setup menu) of D824/D1624.

12 42 (<lock mode>): lock mode command

The command for setup of the slave mode (setup menu) when this equipment is set to "slave mode on."

12 45 (<count><mmc track>) : copy clip command

When this command is received, D-108 will copy (multiple number of tracks can be copied simultaneously) the sound data, as data for copy paste, from the pre-registered clipboard-in point to the clipboard-out point in the track specified by <mmc track>. With completion of copying the data into the clipboard, D824/D1624 will immediately reply with "32 45 (<edit message=01 (completed)>)". If copy cannot be executed due to improper figures of the pre-registered clipboard in/clipboard out points or incorrect track section, the corresponding <edit message> will be returned.

12 46 (<count=01><repeat count>): copy paste command

12 46 (<count><repeat count><mmc track>): copy paste command

When this command is received, D824/D1624 will paste the sound data which has been copied into the clipboard, on the same track from the pre-registered auto punch in point as the starting point for the number of time specified by <repeat count>.

However, if the sound data length in the clipboard is less than 10ms, the specifying the <repeat count> will be limited to "01." Also, by specifying <mmc track>, paste can be executed on other tracks in mono (in one track units) or stereo units (in combinations of tracks 1-2, 3-4, 5-6, 7-8).

Since time corresponding to length of the copy clipped sound data is required to complete the copy paste operation, D824/D1624 immediately replies with "32 46 (<edit message=02 (active)>)" after receiving the command.

Successively upon completing the paste operation, "32 46 (<edit message=01 (completed)>)" is transmitted.

If paste cannot be executed due to improper figures of the pre-registered auto punch in point, insufficient disc capacity, no sound data in the clipboard, etc., the corresponding <edit message> will be replied.

12 47 (<count><mmc track>): erase command

When this command is received, D824/D1624 will erase the data (writes in "0" data) in the section from the pre-registered auto punch in point through auto punch out point in the track specified by <mmc track>. Since time corresponding to length of the erase section is required to complete the erase operation, D824/D1624 will immediately reply by "32 47 (<edit message=02 (active)>)" after receiving the command.

After the completion of erase operation, "32 47 (<edit message=01 (completed)>)" will be transmitted.

If erase cannot be executed due to improper figures of the pre-registered auto punch in point/auto punch out point, incorrect track section, etc., the corresponding <edit message> will be replied.

12 49: clipboard play command

When this command is received, D824/D1624 will playback once from the head of the sound data copied in the clipboard by the copy clip and move clip commands.

Immediately after receiving the command, D824/D1624 will reply with "32 49 (<edit message=02 (active)><count><mmc track>)." The sound data track number is indicated by (mmc track).

Upon completion of playback, "32 49 (<edit message=01 (completed)>)" is sent and clipboard play is ended. If there is no sound data in the clipboard, "32 49 (<edit message=14 (void data)>)" will be sent and clipboard play operation will be interrupted.

12 4A: undo command

Upon receiving this command, D824/D1624 will revert to the condition prior to editing copy paste, erase, move paste, cut, redo operation. With completion of undo operation, D824/D1624 will reply with "32 4A (<edit message=01 (completed)>)." If D824/D1624 is not possible to undo, "32 4A (<edit message=00 (no message)>)" will be replied.

12 4B: redo command

When this command is received, D824/D1624 will return to the condition prior to undo operation.

With completion of redo operation, D824/D1624 will reply with "32 4B (<edit message=01 (completed)>)." If D824/D1624 is not possible to redo, "32 4B (<edit message=00 (no message)>)" will be replied.

12 4D (<count><mmc track>): move clip command

When this command is received, D824/D1624 will copy (multiple tracks can be copied simultaneously) the sound data from the pre-registered clipboard in point to the clipboard out point, as data for move paste operation. With completion copying the data into the clipboard, D824/D1624 will immediately reply with "32 4D (<edit message=01 (completed)>)." If copy cannot be executed by the reason of pre-registered improper clipboard in/clipboard out point figures or incorrect track section, etc., the corresponding <edit message> will be replied.

12 4E (<count=01><repeat count>): move paste command

12 4E (<count><repeat count><mmc track>): move paste command

When this command is received, D824/D1624 will paste the sound data which have been move clipped in the clipboard, for the number of times specified by <repeat count> on the same track from the pre-registered auto punch in point as the starting point. At the same time, the move clipped original

sound data will be erased (data "0" is written in). However, when sound data length in the clipboard is less than 10ms, specifying the <repeat count> will be limited to "01."

Also, by specifying the <mmc track>, paste operation can be executed on other tracks in mono (one track unit) or stereo units (tracks 1-2, 3-4, 5-6, 7-8).

Since time corresponding to length of the move clipped sound data is required to complete the move paste operation, D824/D1624 will immediately reply with "32 4E (<edit message=02 (active)>)" after receiving the command.

Following completion of the move paste operation, "32 4E (<edit message = 01 (completed)>)" will be sent.

If paste cannot be executed due to improper figures of the previously registered auto punch in point, insufficient disc capacity, no sound data is in the clipboard, etc., the corresponding <edit message> will be replied.

12 4F (<channel><channel>): track exchange command

When the D824/D1624 receives this command, the track can be exchange between the specified <channel><channel>. Especially, if the first <channel=00><channel=01>, then exchange by grouping will be executed between channel 1-8 and channel 17-24, and if the next byte <channel=00><channel=02>, then the exchange will be between channel 9-16 and channel 17-24. If it cannot be executed for some reason, an error message will be sent back.

13 3E: product new program command

When the D824/D1624 receives this command, a new program is compiled and the current program is transferred to the new program. As compilation of the new program is comparatively short time, it is replied with "33 3E (<edit message=01 (completed)>)" immediately upon completion of execution. If it cannot be executed for some reason, an error message will be sent back.

13 3F: delete current program command

When the D824/D1624 receives this command, the current program is deleted and succeeding programs moved up and renumbered. If the deleted program is the only tune existing in the track, a new program will be made automatically.

As this delete current program is executed in a comparatively short time, "33 3F (<edit message=01 (completed)>)" will be sent back immediately upon completing the execution.

If it cannot be executed for some reason, an error message will be sent back.

13 41 (<channel><channel>): digital in ch.select command

The audio signal input from SPDIF digital in to assigned to the destination track specified by <channel>. The first <channel> shown in the command is the SPDIF L channel input, and the second <channel> the R channel input. "<channel=0> <channel=0>" indicates the normal analog input.

13 41 (<channel=7F><count><mmc track>): Adat in select command

Channel = 7F indicates that it is Adat In. Normally, it will be "<count=0>" and all channels will be inputs from Adat In.

If <count=0><mmc track> is indicates, then only the tracks selected will be Adat In inputs. "<channel=0><channel=0>" indicates the normal analog input.

13 42 (<channel><channel>): digital out ch.select command

The source channel for digital out is selected.

Normally, the first <channel> shown will be the SPDIF L channel data, and the second <channel> the SPDIF R channel output. (<00><00>) is the default setting. By FDMS-3, any channel within "1 ~ 8" (or 8 ~ 16) can be selected.

13 42 (<channel=7F><channel=0>): Adat out select command

In a device which can be switched between SPDIF and Adat, if the first display is <channel=7F>, then Adat Out can be setup.

13 43(<program>): program change command

The command for PROGRAM CHANGE of D824/D1624. The present program number can be changed to the figure indicated by <program>.

13 44 (<on/off>): click on/off command

The command for setting the metronome on/off of D824/D1624. When ON is set, the metronome signal will be fed to the track 8 output of D824, and the track 16 output of D1624.

13 46 (<on/off>): Bar/Beat Resolution ON/OFF command

The command for ON/OFF of the bar/beat resolution function of this equipments' current program.

13 47 (<midi sync>): Midi Sync Out command

The setup command for MIDI Sync Out mode of this equipments' current program.

13 48 (<MTC offset mode>): MTC offset mode command

The setup command for MTC offset mode of this equipments' current program.

13 49 (<count=3> <on/off> <vari data>): Vari pitch command

13 49 (<count=1> <on/off>): Vari pitch command

The command for setting this equipments' vari pitch ON/OFF and pitch data.

Control of ON/OFF only is possible at <count=1> and both ON/OFF and pitch data can be set at <count=3>.

14 01 (<signature map>): Signature set command

The command for setting the meter of this equipment. If a new data is registered at the bar position where a data exists, the former data will be written over. When this command is received, this equipment will reply with "34 01 (<edit message>)." Upon completing the registration, <edit message> will reply with "01 (completed)," or with "10 (over value error)" if registration is attempted at a non-existing point or an erroneous figure is used.

14 02 (<tempo set map>): Tempo set command

The command for tempo set of this equipment. If a new data is registered in a bar/meter where data already exists, the former data will be written over. When this command is received, this equipment will reply with "34 02 (<edit message>)." Upon completing the registration, <edit message> will reply with "01 (completed)," or with "10 (over value error)" if registration is attempted at a non-existing point or an erroneous figure is used.

14 03 : Tempo map all erase command

When this command is received, this equipment will erase all meter and tempo data in the current program and thus return it to the default state (meter=4/4, tempo: =120). Also, when this command is received, this equipment will reply with "34

03 (<edit message>)." Upon completing the registration, <edit message> will reply with "01 (completed)," or with "10 (over value error)" if registration is attempted at a non-existing point or an erroneous figure is used.

14 04 (<mmc time>): Preroll time set command

The command for setting the current program preroll time at the figure indicated by <mmc time>.

14 06 (<frame rate>): Frame rate set command

The command for setting the current program frame rate at the figure indicated by <frame rate>.

14 08 (<time base>): Time base set command

The command for setting the current program time base of this equipment to that indicated by <time base>.

The Status Request Command

22 21: loop operation status request

The command inquiring the loop operation mode setup status. D824/D1624 will reply with "32 21 (<loop op.mode=12>)."

22 22: loop on/off status request

The command inquiring the loop on/off (=ON/OFF of AUTO RETURN) setup status. D824/D1624 will reply with "32 22 (<on/off>)."

22 28: post locate status request

The command inquiring the post locate mode (ON/OFF of AUTO PLAY) setup status. D824/D1624 will reply with "32 28 (<post locate mode>)."

22 2D: auto rec status request

The command inquiring the auto rec mode setup status and this is replied by "32 2D (<edit message>)." Reply from D824/D1624 against this status request will be either one of the following:

<edit message> =05: Possible to undo rehearsal mode.
=06: Possible to undo take mode.
=72: off

22 41: lock status request

The command inquiring the slave on/off setup status and the lock status. D824/D1624 will reply with "32 41 (<lock status>)."

22 42 : lock mode status request

The command for inquiring the lock mode setup status and this is replied with "32 42 <lock mode>."

22 45: copy clip status request

The command inquiring the clipboard condition. If there is a copy paste data in the clipboard, D824/D1624 will reply with "32 45 (<edit message=01>)." If data in the clipboard is for move paste or there is no valid data in it, it will reply will "32 45 (<edit message=14 (void data)>)."

22 46: copy paste status request

The command inquiring execution status of copy paste editing. When this command is received, D824/D1624 will reply

with either "32 46 (<edit message=02><mmc time>)" or "32 46 (<edit message=00>)." <mmc time> indicates unprocessed time until completion.

22 47: erase status request

The command inquiring execution status of erase.

When this command is received, D824/D1624 will reply by either "32 47 (<edit message=02><mmc time>)" or "32 47 (<edit message=00>)." <mmc time> indicates unprocessed time until completion.

22 4D: move clip status request

The command inquiring the clipboard status. If there is a move paste data on the clipboard, D824/D1624 will reply with "32 4D (<edit message=01>)." If data in the clipboard is for copy paste or there is no valid data on it, "32 4D (<edit message=14 (void data)>)" will be replied.

22 4E: move paste status request

The command inquiring the move paste execution status.

When this command is received, D824/D1624 will reply with "32 4E (<edit message=02><mmc time>)" or "32 4E (<edit message=00>)." <mmc time> indicates unprocessed time until completion.

23 41: digital in channel status request

23 41: adat in channel status request

The command inquiring the digital in channel setup status. When this command is received, D824/D1624 will reply with "33 41 (<channel> <channel>)" or "33 41 (<channel=7F> <count> <mmc track>)."

23 42: digital out channel status request

23 42: adat out channel status request

The inquiring the digital out channel setup status.

When this command is received, D824/D1624 will reply with "33 42 (<channel><channel>)" or "33 42 (<channel=7F> <channel=0>)."

23 43: program status request

The command inquiring the presently operating program number. When this command is received, D824/D1624 will reply with "33 43 (<program>)."

23 44: click on/off status request

The command inquiring the metronome on/off status of D824/D1624. When this command is received, D824/D1624 will reply with "33 44 (<on/off>)."

23 45: level status request

The command inquiring the present output level data of the 1~8 tracks. In D824/D1624 as the level data is updated about every 40msec., inquiry in 40msec. units is effective.

When this command is received, D824/D1624 will reply with "33 45 (<count=10><level data>)."

23 46: resolution status request

The command for inquiring the resolution on/off setup status. When this command is received, this equipment replies with "33 46 <on/off>."

23 47: midi sync out status request

The command for inquiring on status of the midi sync out setup condition. When this command is received, this equipment replies with "33 47 <midi sync>."

23 48: MTC offset mode status request

The command for inquiring the MTC offset mode setup status. When this command is received, this equipment replies with "33 48 <MTC offset mode>."

23 49: vari pitch status request

The command for inquiring status of vari pitch on/off and vari pitch data. When this command is received, this equipment replies with "33 49 (<count=3> <on/off> <vari data>)."

24 01 (<event number>): signature map request

The command for inquiring the meter setup. Order number counting from the leading tune must be specified in the event number (The first event is expressed as "event number=00." When this command is received, this equipment replies with "34 01 (<signature map>)."

24 02 (<event number>): Tempo set map request

The command for inquiring tempo data. Order number from the leading tune must be specified in the event number (The first event is expressed as "event number=00." When this command is received, this equipment replies with "34 02 (<tempo set map>)."

24 04: preroll time status request

The command for inquiring the preroll time setup status. When this command is received, this equipment replies with "34 04 (<mmc time>)."

24 05: remain time request

The command for inquiring the disk remaining time which is recordable. When this command is received, this equipment replies with "34 05 (<mmc time>)."

24 06: frame rate status request

The command for inquiring the frame rate setup status. When this command is received, this equipment replies with "34 06 (<frame rate>)."

24 08: time base status

The command for inquiring the setup status of the time base shown in the display. When this command is received, this equipment replies with "3408 (<time base>)."

Explanation on the Status Reply

32 21 (<loop op.mode>): loop operation mode status reply

This is the reply against the "22 21" loop operation status request command. <loop op.mode=12> is the only status data of D824/D1624 and any other setting is not permissible.

32 22 (<on/off>): loop on/off status reply

This is the reply against "22 22" loop on/off status request.

32 28 (<post locate mode>): post locate mode status reply

This is the reply against "22 28" post locate status request. <post locate mode=12 or 15> is the only status data of D824/D1624 and any other setting is not permissible.

32 2D (<edit message>): auto rec status reply

This is the reply against the "12 2D" auto rec command or the "22 2D" auto rec status request.

32 41 (<lock status>): lock status reply

This is the reply against the "22 41" lock status request.

32 42 (<lock mode>): lock mode status reply

This the reply against the "22 42" lock mode status request.

32 45 (<edit message>): copy clip status reply

This is the reply against the "12 45" copy clip command or the "22 45" copy clip status request.

32 46 (<edit message>): copy paste status reply

32 46 (<edit message><mmc time>): copy paste status reply
This is the reply against the "12 46" copy paste command or the "22 46" copy paste status request. <mmc time> indicates the unprocessed time until completion of copy paste editing.

32 47 (<edit message>): erase status reply

32 47 (<edit message><mmc time>): erase status reply
This is the reply against "12 47" erase command or "22 47" erase status request.

32 49 (<edit message><count><mmc track>): clipboard play status reply

This is the reply against the "12 49" clipboard play command. If there is no sound data in the clipboard, "32 49" (<edit message=14 (void data)>)" will be replied. <mmc track> indicates the sound data track number.

32 4A (<edit message>): undo status reply

This is the reply against the "12 4A" undo command. Either <edit message=01 (completed) or <edit message=14 (void data)> will be replied.

32 4B (<edit message>): redo status reply

This is the reply against the "12 4B" redo command. Either <edit message=01 (completed)> or <edit message=14 (void data)> will be replied.

32 4D (<edit message>): move clip status reply

This is the reply against the "12 4D" move clip command or "22 4D" move clip status request.

32 4E (<edit message>): move paste status reply

32 4E (<edit message><mmc time>): move paste status reply
The reply against the "12 4E" move paste command or the "22 4E" move paste status request. <mmc time> indicates the unprocessed time until completion of move paste editing.

32 4F (<edit message>): track exchange status reply

This is the reply against the "12 4F" track exchange command.

33 3E (<edit message>): product new program status reply

This is the reply against the "13 3E" product new program command.

33 41 (<channel> <channel>): digital in channel status reply**33 41 (<channel=7F> <count> <mmc track>): adat in status reply**

This is the reply against the "23 41" digital in ch. st. request. The first <channel> indicates the track number assigned to the L channel of the digital audio signal (S/P DIF) from the DATA IN connector, and the second <channel> the track number assigned to the R channel. If digital in is set to "Adat," the reply for the first <channel> will be 7F and then <count> <mmc track>, in this order. In the <mmc track>, the track bit map which is the Adat input, is expressed by "1" (In this equipment, the reply will all be "1", or in other words, all tracks will be collectively converted to Adat inputs or analog inputs).

33 42 (<channel> <channel>): digital out channel status reply**33 42 (<channel=7F> <channel=00>): adat out status reply**

This is the reply against the "23 42" digital out ch. st. request. The first <channel> indicates the track number assigned to the L channel output of the digital audio signal (S/P DIF) from the DATA OUT connector, and the second <channel> the track number as signed to the R channel output. If digital out is set to "Adat," the reply for the first <channel> will be 7F and that for the second <channel> will be 00.

33 43 (<program>): program status reply

This is the reply against the "23 43" program status request. <program> indicates the presently operating program number.

33 44 (<on/off>): click status reply

This is the reply against the "23 44" click status request. It indicates the on/off setting of the metronome function.

33 45 (<count=10><level data>): level status reply

This is the reply against the "23 45" level status request and it indicates the present track 1-16 output level data.

In D824/D1624, as level data is updated 40msec., it will be effective if inquiry is made in 40msec. units.

33 46 (<on/off>): bar/beat resolution status reply

This is the reply against "23 46" bar/beat resolution status request.

33 47 (<midi sync>): midi sync out status reply

This is the reply against "23 47" midi sync out status request.

33 48 (<MTC offset mode>): MTC offset mode status reply

This is the reply against "23 48" MTC offset mode status request.

33 49 (<count=3> <on/off> <vari data>): vari pitch status reply

This is the reply against "23 49" vari pitch status request and is indicating the vari pitch function on/off and the present vari pitch setup figure.

34 01 (<signature map>): signature map status reply

This is the reply against "24 01" (<event number>) signature map request. The signature map of the event indicated by the <event number> is replied. If there is no event specified (Example: Such as when <event number=5> is requested even though there is only 5 meters registered), it will be replied with all figures at 00 of the <signature map>.

34 02 (<tempo set map>): tempo set map status reply

The reply against "24 02" (<event number>) tempo set map request. Tempo set map of the event indicated by the <event number> is replied. If there is no event specified (Example: Such as when <event number=20> is requested although only 10 is setup for tempo), it will be replied with all figures at 00 of the <signature map>.

34 04 (<mmc time>): preroll set map status reply

This is the reply against "34 04" preroll time status request and this is replied with the presently set preroll time.

34 05 (<mmc time>): remain time reply

This is the reply against "24 05" remain time request, and is replied with the recordable disc remaining time.

34 06 (<frame rate>): frame rate status reply

This is the reply against "24 06" frame rate status request, and is replied with the presently set frame rate.

34 07 (<fs rate>): fs rate status reply

This is the reply against "24 07" fs rate status request, and is replied with the presently set fs (sampling frequency).

34 08 (<time base>): time base status reply

This is the reply against "24 08" time base status request, and is replied with the presently set time base (in the display).

Maintenance

Cleaning the exterior

* For normal cleaning, use a soft dry cloth.

For stubborn dirt, moisten a cloth in diluted detergent, wring it out firmly, and wipe the dirt off. Then polish with a dry cloth. Never use solvents such as alcohol, thinner or benzene, since these will damage the printing and finish of the exterior.

Specifications

RECORDER SECTION

Recording Medium	:	3.5 inch, E-IDE type hard disk External SCSI device (SCSI-2 unbalanced transfer)
Recording Format	:	FDMS3 version 2
Save/Load Format	:	SCSI, FDIO-1 version2
Sampling Frequency	:	44.1kHz, 48kHz, 96kHz
Quantization	:	16bit / 24bit
Data Save/Load	:	SCSI (normal mode)
A/D Converter	:	24bit Delta Sigma 128 times over sampling
D/A Converter	:	24bit Delta Sigma 128 times over sampling
No. of Recording Tracks (D824)	:	24 (8 real tracks + 16 additional tracks)
No. of Recording Tracks (D1624)	:	24 (16 real tracks + 8 additional tracks)
No. of Simultaneous Recording Tracks (D824)	:	8 (analog/digital in)
No. of Simultaneous Recording Tracks (D1624)	:	8 (analog), 16 (digital in)
No. of Simultaneous Reproduce Tracks (D824)	:	8
No. of Simultaneous Reproduce Tracks (D1624)	:	16, 8 (at 96kHz/24bit)
No. of Programs	:	99
No. of Locate Memories	:	100
Pitch Control	:	+/- 6% (0.1 step)
Crossfade	:	10msec, 5msec (at 24bit/96kHz)
R/P Frequency Response	:	20Hz to 20kHz +/-1dB 20Hz to 43kHz +/-2dB (at fs:96kHz)
Dynamic Range	:	More than 108dB (typical)
Channel Separation	:	More than 80dB (at 1kHz, 0dB, 24bit)
T.H.D.	:	Less than 0.004% (1kHz, -12dB) (typical)

INPUT/OUTPUT

Analog Input	
Connector (1 to 8)	: RCA pin jack
Input Impedance	: More than 10k ohm
Reference Input Level	: -10dBV
Analog Output	
Connector (D824: 1 to 8, D1624: 1 to 16)	: RCA pin jack
Load Impedance	: More than 10k ohm
Reference Output Level	: -10dBV
Data In	
Connector (D824: 1-8, D1624: 1-8, 9-16)	: Optical
Format	: IEC 958 Part3 (S/P DIF) Alesis Proprietary Multichannel Optical Digital Interface
Data Out	
Connector (D824: 1-8, D1624: 1-8, 9-16)	: Optical
Format	: IEC 958 Part3 (S/P DIF) Alesis Proprietary Multichannel Optical Digital Interface
WORD Input	
Connector	: BNC
Input Level	: TTL level
WORD Output	
Connector	: BNC
Output Level	: TTL level
RS-422	
Connector	: D-sub 9pin
Protocol	: Sony 9pin protocol, ES buss
RS-422 THRU	
Connector	: D-sub 9pin
Output	: Direct output of RS-422
MIDI In/Out/Thru	: DIN 5pin
Punch In/Out	: 6mm dia phone jack (option model 8051)
SCSI Port	: D-sub 50pin (half pitch)

PHYSICAL

Dimensions	:	482(W) x 148(H) x 381(D)mm
Weight	:	7.0kg
Power Requirement	:	120VAC 60Hz 230V ~ 50/60Hz
Power Consumption (D824)	:	30W
Power Consumption (D1624)	:	35W

* Specifications and appearance are subject to change without notice for product improvement.

* "Adat" and the  symbol are trademarks of Alesis Corporation.

* FDMS-3: Fostex Disk Management System-3.

* FDIO-1 Ver.2: Fostex Data In Out-1 Ver.2

Memo