

Model A-2

2 TRACK RECORDER/REPRODUCER

Owner's Manual



TABLE OF CONTENTS			PAGE
SECTION 1	Feature Descriptions		2
SECTION 2	Introduction		4
SECTION 3	Installation		5
SECTION 4	Recording and Playback		7
SECTION 5	Editing		9
SECTION 6	Creative Use of the Pitch Control		10
SECTION 7	Routine Maintenance		11
SECTION 8	Specifications		14
	Safety Instructions		15

**WARNING: To avoid possible electric shock hazard,
do not expose this appliance to rain or moisture.
There are no user serviceable parts inside.
Refer servicing to qualified service personnel.**

Figure 1. Model A-2 front panel features.

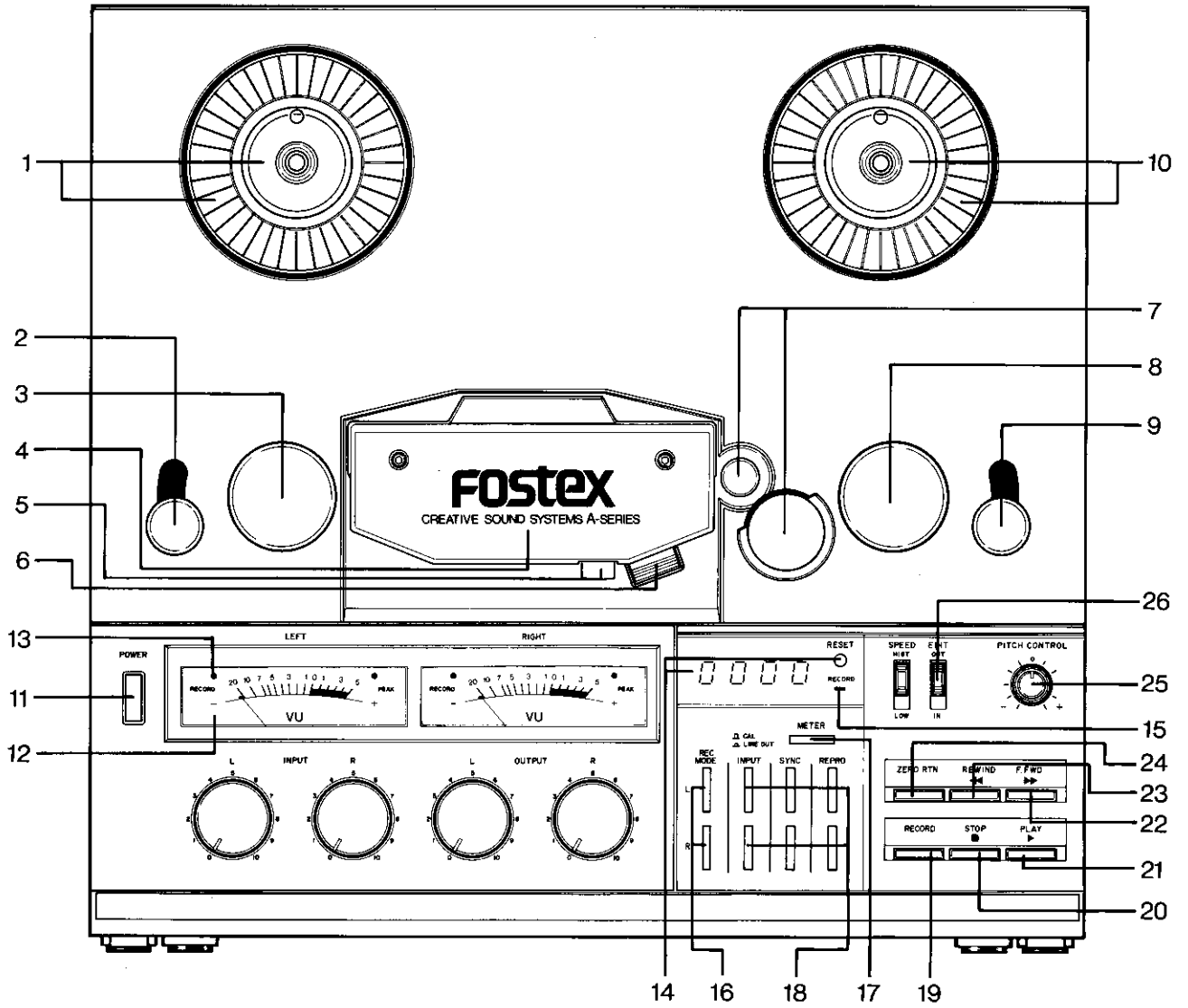
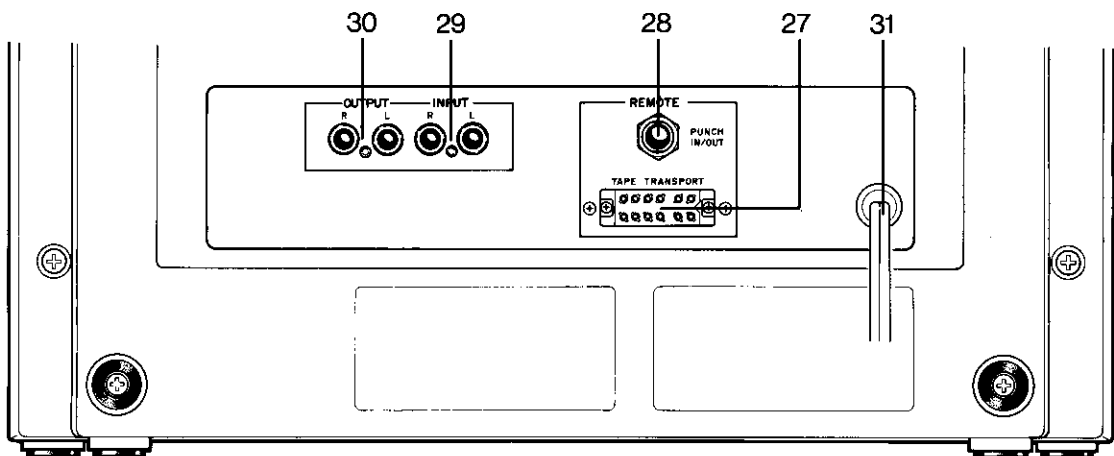

Figure 2. Model A-2 rear panel features.



SECTION 1 FEATURE DESCRIPTIONS

TRANSPORT

1. SUPPLY REEL TABLE AND REEL CLAMP

The reel table accommodates 7" diameter reels. Place a reel on the table, and turn the clamp clockwise to secure the reel.

2. SUPPLY TENSION ARM AND TAPE GUIDE

This arm and guide maintain stable travel on the segment of tape between the supply reel and the head assembly. When a reel of tape is threaded, the arm must be placed under partial tension, (caused to move upward from its fully extended position) before the transport will function.

3. SUPPLY IDLER ROLLER

This roller establishes the proper angle for tape as it approaches the heads, ensuring correct wrap at the erase head. The roller also serves as a mechanical filter (it stabilizes the tape) to prevent flutter.

4. HEAD ASSEMBLY (HEAD STACK)

Beneath the cover are located three heads, (a) a 2 track erase head, (b) a 2 track combination record/play head, and (c) a playback head.

5. CUE LEVER

Pushing this lever toward the head permit monitoring of the recording in either fast forward or rewind mode by retracting the tape lifter and allowing tape to contact the playback head.

CAUTION: To prevent possible damage to speakers (caused by a loud, high pitched squeal), be sure that monitor amplifier volume is reduced before actuating the CUE lever. Avoid continuous use of CUE; prolonged fast winding or rewinding with tape contacting the head can cause undue wear.

6. HEAD SHIELD

A retractable gate is used to cover the playback head area, and should be up during playback. This shields the sensitive circuitry from stray hum and noise. This head shield can be retracted manually (for threading tape and editing) by pushing it down in the deck plate, where it locks in place. A second short push will release the shield, which then returns up to the extended position.

7. CAPSTAN AND PINCH ROLLER

The capstan motor (beneath the deck plate) rotates at a constant speed whenever the unit is in play, edit/play, or record mode. The pinch roller holds the tape against the capstan, pulling the tape past the head assembly at the set record/play speed.

The record/play speed (capstan motor speed) is adjustable $\pm 10\%$ from the nominal 15 ips (38 cm/s) or 7-1/2 ips (19 cm/s) by means of the PITCH control [25].

8. TAKEUP IDLER ROLLER

This roller stabilizes the tape motion between the capstan/pinch roller assembly and the takeup tension arm.

9. TAKEUP TENSION ARM AND GUIDE

This arm and guide maintain stable travel on the segment of

tape between the capstan and the takeup reel. When a reel of tape is threaded, the arm must be placed under partial tension (caused to move upward from its fully extended position) before the transport will function.

10. TAKEUP REEL TABLE AND REEL CLAMP

The reel table accommodates 7" (17 cm) diameter reels. Place a reel on the table, and turn the clamp clockwise to secure the reel.

METER PANEL

11. POWER SWITCH

Depressing this switch turns on the AC power, as indicated by the VU meter lights turning on.

12. VU METERS

There are 2, illuminated VU meters, one for each track of the tape. Each meter will display the level at the corresponding channel line output; this level, in turn, is derived from either the input to the track, tape playback from the record/play head or the playback head. The actual output signal is determined by the position of the RECORD MODE and INPUT/SYNC/REPRO buttons.

13. LED INDICATOR

In the left corner of each meter is an LED indicator. When the LED is blinking, the corresponding track is in "record ready" mode. When the LED is on continuously, the corresponding track is in record mode.

If the LED is not illuminated, the track may or may not be in safe mode; refer to Section 4 for details.

CONTROL PANEL

14. TAPE INDEX COUNTER AND RESET BUTTON

A 4 digit display indicates relative tape position (by means of a photointerrupter circuit on the transport supply spindle). Pressing the adjacent RESET button sets the display at 0000. To take advantage of the ZERO RTN function [24], it is recommended that the RESET button be pressed at the beginning of a "take."

15. RECORD INDICATOR LED

This LED blinks to indicate the unit is "record ready," and turns on continuously when either track (or both) is actually recording.

16. RECORD MODE SELECTORS

These two pushbuttons determine whether recording can commence on a given track. In the up position, that track will be in SAFE mode and no recording will occur. In the down position, that track will be in the record READY mode and the LED, in the left corner of the meter scale, for that track will blink. The specific function also depends on whether or not tape is stopped or is advancing in record ready mode.

a) If tape is stopped, depressing a RECORD MODE button places the corresponding track in record ready mode, and the LED in the left corner of the meter scale will blink; the record LED [15] adjacent to the tape counter will not blink. If the RECORD and PLAY buttons are subsequently depressed, tape begins recording, the meter LED [13] stops blinking and remains on, and the record LED [15]

also turns on.

- b) If tape is rolling in play mode, depressing a RECORD MODE button has the same effect as in a) above; it readies the track for recording.
- c) If tape is rolling in record ready mode (i.e., RECORD and PLAY buttons have been depressed), the record LED [15] adjacent to the tape counter is blinking, and so are the LEDs in the left corner of the meter scales but no recording is yet taking place. Subsequent depression of a RECORD MODE button immediately causes that track to enter record mode; the record LED [13] now remains on (as does the LED associated with the VU meter [12]).

17. METER-CAL/LINE OUT

This switch selects the signals at points before and after the OUTPUT level control for monitoring with the VU meter. In the CAL position, the meter indication is not affected by the OUTPUT level control knob position as the signal pick up point is before the OUTPUT control pot. Although the meter will indicate 0 VU at the rated output level of -10 dBV (0.3V) for this recorder, if an output of 0.5V or 1V is required, the OUTPUT level control is adjusted until this level is obtained with this METER select at CAL. The CAL position is also used for setting the INPUT level control while monitoring with the VU meter. At the LINE OUT position of this switch, the VU meter is monitoring signals after the OUTPUT level control.

18. INPUT/SYNC/REPRO

If the INPUT button is depressed, the input signal goes to the rear panel OUTPUT jack and is also monitored by the VU meter.

If the SYNC button is depressed, depending on whether the recorder is in the record mode or not, either the input signal or sync output is obtained at the OUTPUT jack and monitored by the VU meter.

When the SYNC button is depressed, the signals going to the OUTPUT jack and VU meter will be, the input signal when in the record mode or; SYNC output when in other than the record mode.

If the REPRO button is depressed, playback output of the reproduce head goes to the OUTPUT jack and the VU meter.

19. RECORD BUTTON

The transport rolls tape and either records (or is ready to record) when this button and the PLAY button are simultaneously depressed. Whether this unit is placed in record ready or record mode depends upon the status of the RECORD TRACK selectors [16].

20. STOP BUTTON

Depressing the STOP button cancels any transport function and stops tape motion. (Whether tape was moving due to ZERO RTN, REWIND, F.FWD, RECORD or PLAY, the tape will stop.)

21. PLAY BUTTON

Depressing the PLAY button places the transport in play mode, advancing tape onto the take up reel (from left to right) at a constant speed of 15 ips (38 cm/s) or 7-1/2 ips (19 cm/s) plus or minus any deviation set with the PITCH control [25].

22. FAST FORWARD BUTTON (F.FWD/>>)

Depressing this button cancels any other transport function and causes the tape to wind onto the takeup reel (from left to right) at high speed. If the transport had been in rewind or ZERO RTN mode, tape will first stop momentarily, then begin forward winding.

23. REWIND BUTTON (REWIND/<<)

Depressing this button cancels any other transport function and causes the tape to wind onto the supply reel (from right to left) at high speed. If the transport had been in fast forward or play mode, tape will first stop momentarily, then begin rewinding.

24. ZERO RETURN BUTTON (ZERO RTN)

Depressing this button cancels any other transport function and causes the tape to wind onto the supply reel (from right to left) at high speed until the INDEX COUNTER [14] displays 0000, at which point the tape automatically stops. If the transport had been in fast forward or play mode, tape will first stop momentarily, then begin rewinding to zero. If the transport had been in rewind mode, it will continue rewinding until the counter displays 0000.

25. PITCH CONTROL

This control can be used to vary the constant tape speed by $\pm 10\%$ during record or play modes. For a nominal 15 ips (38 cm/s) or 7-1/2 ips (19 cm/s) tape speed, center the control (it will "click" into position). Turning the knob CCW decreases tape speed, and turning it CW increases tape speed.

26. EDIT SWITCH

Normally this switch is in the OUT position. When it is necessary, for editing purposes, to play a tape and spill a portion of it without winding it onto the takeup reel, place this switch in the IN position. This defeats the shut off switch on the takeup tension arm, and permits the transport to run while spilling tape.

CAUTION: If EDIT is switched IN during any mode other than STOP, tape motion will come to a halt (pressing PLAY twice will stop tape, then cause tape to play and spill). If the switch is engaged while the transport is stopped, the unit can only be placed in play mode, not fast forward or rewind modes. This avoids inadvertent massive tape spills that would occur with lost takeup tension during fast winding.

To return to normal operation, manually place tension on the takeup reel and switch EDIT to OUT position.

27. TRANSPORT REMOTE CONTROL CONNECTOR

An optional remote control unit, Model 8030, is available for the A-2. Plug in the remote control cable to the connector marked TAPE TRANSPORT.

28. REMOTE PUNCH-IN/PUNCH-OUT JACK

A foot switch is available to place the transport in record mode during punch-ins, and to return it to record ready mode (punch-out). Plug in the cable from the foot switch to this jack.

NOTE: *If one or both RECORD MODE selectors is depressed, and the transport is placed in play mode, stepping on the foot switch once will cause the track(s) to enter record mode; stepping on the switch a second time will cause the track(s) to punch out (cease recording).*

If the transport is manually placed in record mode by pressing the RECORD and PLAY buttons, the foot switch cannot be used for a punch out.

29. INPUT JACKS

These 2 jacks apply line level signals to the RECORD MODE selectors and ultimately to record channels L and R. Connect the buss or line outputs from the mixer to these jacks.

SECTION 2 INTRODUCTION

The Fostex Model A-2 is a compact, full capability 2 track mastering machine that utilizes 1/4" wide recording tape. The machine has fully synchronous record/play capability for sync recording and punch-in recording. There are 2 input jacks, with a front panel selector switch for each track which set the tracks to either the SAFE or record READY mode.

The Model A-2 tape play/record speeds are 15 inches per second (38 cm/s) and 7-1/2 inches per second (19 cm/s), and has very low wow and flutter, and a high signal-to-noise ratio.

Of special interest to musicians and song writers is a remote FOOT SWITCH that begins and ends recording. Thus, hands remain free for playing instruments, etc. during punch-ins and punch-outs. A PITCH control varies both the record and playback speed, and is useful for a variety of effects such as tuning or retiming programs. Other convenient features include an electronic counter and large LED display which constantly read out the tape position. To facilitate playback, a zero return pushbutton automatically rewinds the tape and stops it at a count approximately 0000 (there may be a small overshoot). The dump edit feature allows spilling a portion of tape, for editing purposes, without winding it onto the takeup reel.

Fostex's engineers have designed the A-2 to meet the special needs of the serious small studio or production facility. It combines ease of operation, excellent flexibility and low operating costs in an extremely reliable package. Your A-2 will provide years of top audio performance with a minimum of servicing. Routine maintenance takes less time because Fostex provides easy access to the transport and record/reproduce amplifiers.

HOW TO USE THIS MANUAL

While it may be possible to "get by" without reading this manual, the utmost in creative results can only be obtained when one is thoroughly acquainted with the A-2 and its full capabilities. We suggest quickly reading this manual once before using the A-2, then re-reading the manual later, after becoming familiar with the basic functions of the machine.

30. OUTPUT JACKS

These 2 jacks normally carry the output from tracks L and R of the recorder. An exception occurs, however, if any of the INPUT selector buttons is depressed, in which case the associated output(s) are derived from the input to the track rather than the reproduce amplifier output.

31. AC POWER CORD

Plug this cord into an AC power outlet. Check the label on the A-2 rear panel to ensure it is compatible with the power line voltage and frequency.

Section 1 contains brief descriptions of each feature. This is handy for quick reference, although for a more detailed step-by-step guide to connections, recording and playback, consult Sections 3 and 4. The rest of the manual deals with more specialized areas such as editing (Section 5), creative use of the pitch control (Section 6), and maintenance (Section 7).

Routine maintenance procedures, such as degaussing and cleaning, should be done on a regular basis. Alignment can be done regularly, or may be needed less often, depending on the demands of the application, environmental factors, and whether tape formulations change. Servicing should be referred only to qualified service personnel.

SECTION 3 INSTALLATION

Unpack the unit, and, before making any electrical connections, inspect for any evidence of possible shipping damage. Save all packing materials at least until you have verified that the unit is working properly. If there is any evidence of damage due to rough handling, consult your Fostex dealer before connecting or operating the unit.

CABLES

The A-2 has high impedance unbalanced inputs and outputs. It is recommended that all cables be kept to the shortest practical length, with a maximum of 10 feet (3 meters). Use only high quality cables with tightly braided shields, multiple-stranded center conductors, and low internal capacitance. Such cables minimize high frequency losses, and reduce susceptibility to hum. Separate input cables from output cables by at least a few inches, and keep all signal cables away from AC power cords by the greatest practical distance. If AC and signal cables must intersect, they should cross at right angles.

RECORD INPUTS

The two A-2 INPUT jacks are unbalanced, high impedance RCA type phono jacks which accept nominal -10 dBV (0.3V) line level signals from a low or high impedance source. If the mixer has $+4$ dBm (1.23 V) line level outputs, it is necessary to reduce this level by installing 10 or 15 dB attenuation pads between the mixer outputs and the A-2 inputs.

Such pads are commercially available. Microphones cannot be connected directly to the A-2 unless a microphone preamplifier is used to increase the signal level. However, many electronic musical instruments (e.g., electronic piano, synthesizer, etc.) can be connected directly to the recorder inputs.

CAUTION: Never connect a speaker-level output, such as the output of a power amplifier or guitar amplifier, to the A-2 INPUT jacks unless a suitable direct box is used. The direct box should attenuate the signal to a suitable -10 dBV level, which prevents overdriving the recorder. The direct box also should include an isolation transformer, which avoids hum by preventing ground loops and also avoids electrical shock hazard.

OUTPUTS

The two A-2 OUTPUT jacks are unbalanced RCA type phono jacks that deliver nominal -10 dBV (0.3V) line level signals to any high impedance mixer or monitor amplifier inputs.

NOTE: Most mixers with line inputs rated at $+4$ dBm nominal level do have input trim or gain controls that can be set for the necessary increased sensitivity to accommodate the recorder's -10 dBV outputs. If the sensitivity cannot be increased, it is O.K. to use the $+4$ dBm inputs, but there may be some degradation of S/N ratio.

Figure 3. Connection of the A-2 in a typical stereo recording/playback system.

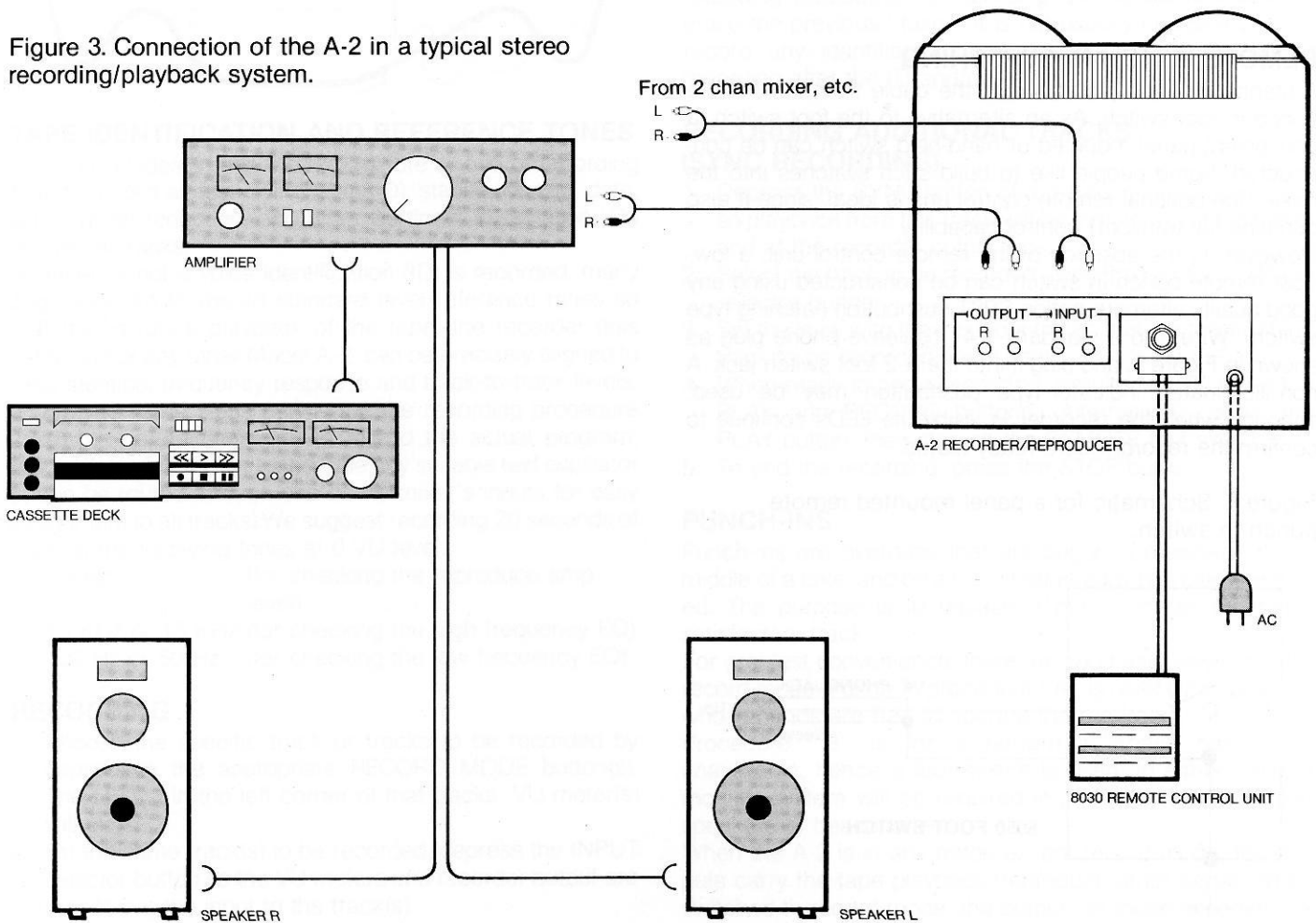

REMOTE CONTROL CONNECTION

The optional Model 8030 Remote Control Unit plugs into the multi-pin connector on the A-2 rear panel. This hand-held unit provides remote control of transport functions (RECORD, STOP, PLAY, F. FWD, REWIND, ZERO RETURN). The functions served by each connector pin are shown in Figure 4.

Figure 4. A-2 Remote connector pin assignment.

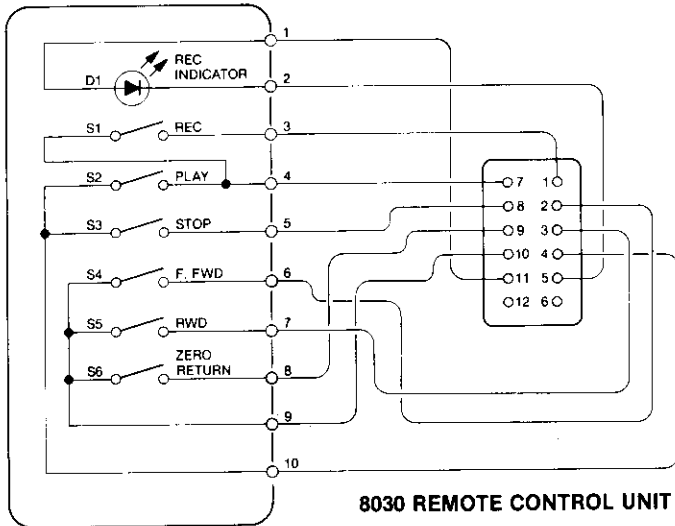

AC CONNECTIONS

Before plugging the recorder into an AC outlet, make sure the voltage and frequency are correct. It is usually a good idea to connect the mixer and the recorder to the same AC outlet, or at least the same leg of the AC service, as this minimizes any potential difference between chassis grounds in the equipment and thus minimizes hum. This is especially important if the mixer and recorder both have grounded (3-prong) AC cords.

PLACEMENT AND MOUNTING CONSIDERATIONS

The A-2 can be operated in a vertical, horizontal or tilted position. Be sure that it is firmly supported, however, and that adequate ventilation space is provided. Also, be sure there is adequate clearance for the larger tape reels.

REMOTE PUNCH-IN SWITCHING

A standard phone jack accepts the cable from the remote punch-in foot switch. As an alternative to the foot switch, a convenient panel-mounted or hand-held switch can be constructed. Some people like to build such switches into the mixer; the optional remote control unit is ideal, since it also contains full transport control capability.

However, in the absence of the remote control unit, a low-cost remote punch-in switch can be constructed using any good quality alternate-action SPST pushbutton (latching type switch). Wire it to a standard 1/4" tipsleeve phone plug as shown in Figure 5, and plug it into the A-2 foot switch jack. A non-illuminated indicator-type pushbutton may be used, although when the recorder is visible its LEDs continue to confirm the record/record ready status.

Figure 5. Schematic for a panel mounted remote punch-in switch.

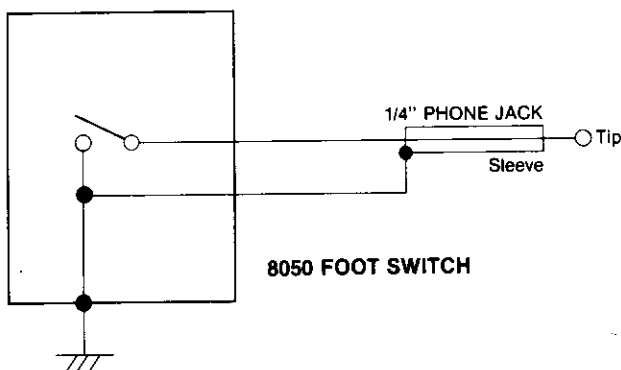

SECTION 4 RECORDING AND PLAYBACK

WHAT KIND OF TAPE TO USE

A 7" reel of 1 mil tape, which is about 1800 feet long (550 meters), plays for 22 minutes at the standard 15 ips (38 cm/s) speed of the Model A-2. Tapes thinner than 1 mil are not recommended since they are more susceptible to wear, stretching and breakage.

LOADING TAPE ON THE TRANSPORT

Thread a blank tape on the transport (refer to Figure 6). We recommend using Ampex 357, Scotch 227, or an equivalent tape formulation; the bias and EQ are factory aligned for these premium quality tapes. If another tape is used, it will be necessary to realign the electronics (See section 7).

Figure 6. Tape threading path.

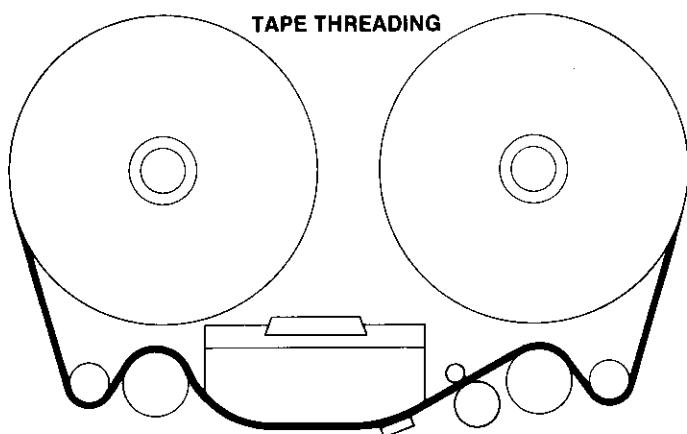

TAPE IDENTIFICATION AND REFERENCE TONES

It is a good idea to use the first minute or two of recording time to record an identifying label (ID), stating the title, date, artist, noise reduction, and other pertinent information. Do this on all tracks.

Whether or not a voice identification (ID) is recorded, many engineers like to record standard level reference tones so that during future playback of the tape, the recorder (this same unit or any other Model A-2, can be precisely aligned to yield identical frequency response and track-to-track levels. Follow the same steps outlined in the recording procedure (next) but before beginning to record the actual program, record the voice and/or tones. Use any suitable test oscillator (it can be routed through one of the mixer's inputs for easy assignment to all tracks). We suggest recording 20 seconds of each of the following tones at 0 VU level:

- 1 KHz (for checking the reproduce amp level)
- 10 KHz or 15 KHz (for checking the high frequency EQ)
- 100 Hz or 50 Hz (for checking the low frequency EQ)

RECORDING

1. Choose the specific track or tracks to be recorded by depressing the appropriate RECORD MODE button(s). The LED(s) in the left corner of that track's VU meter(s) will blink.
2. On the same track(s) to be recorded, depress the INPUT selector button so the VU meters and recorder output are monitoring the input to the track(s).

3. Press the RESET button to zero the counter so it will be easy to return to the beginning of the recording.
4. Set levels with the input level control so that the meters of those tracks to be recorded show peaks at -3 VU to 0 VU.
5. When ready to begin recording, simultaneously press the PLAY and RECORD buttons. (Alternately, press the PLAY button, then step on the REMOTE foot switch.)
6. To end the recording, press the STOP button.

NOTE: One generally listens to the tracks as they are being recorded. This can be accomplished by monitoring the output from the mixer to the recorder, but a better approach is to set up the mixer so that it is monitoring both outputs from the recorder. Then, set up the recorder so that its outputs carry the signal(s) being recorded, as well as any previously recorded tracks. The recorder settings necessary are included in the following procedures.

CHECKING THE RECORD TRACKS

1. Press the ZERO RTN button to rewind the tape.
 2. Release the RECORD MODE button(s) to prevent accidental erasure of the track(s).
 3. Release the SYNC or REPRO button so the meters and output jack will pick up the playback signal, not the input.
 4. Press the PLAY button and listen to the recording.
- If the recording track must be redone, simply repeat the initial recording procedure; re-recording on the same track will erase the previous "take." It is not usually necessary to re-record any identification or reference tones; just begin recording after the ID and/or tones.

RECORDING ADDITIONAL TRACKS (SYNC RECORDING)

1. Depress the SYNC button of a previously recorded track so playback from this track will be monitored on the meter and at the recorder output jack.
2. Select the track to be recorded using the RECORD MODE selector buttons.
3. Set the level with the input control so that the meter of the track to be recorded show peaks at -3 VU to 0 VU.
4. When ready to begin recording, simultaneously press the PLAY and RECORD buttons. (Alternatively, press the PLAY button, then step on the REMOTE foot switch.)
5. To end the recording, press the STOP button.

PUNCH-INS

Punch-ins are overdubs that are begun somewhere in the middle of a take, and on a track that already has been recorded. The purpose is to replace a portion of an otherwise satisfactory track.

For greatest convenience, there are two basic ways to enter record mode. Punch-in procedure "A" is used by a someone whose hands are free to operate the recorder.

Procedure "B" is for a performer whose hands are unavailable, hence a foot switch is used. In either case, a monitor system will be required (e.g., mixer, amplifier, and speakers or headphones).

When the A-2 is in any mode except record mode, the outputs carry the tape playback (reproduce amp) signal. When switched to record mode, the outputs of those channels ac-

tually recording are switched to source monitoring (the input to the channel also appears at the output jack). Although the A-2 automatically switches to source monitor when recording, sometimes this capability is desired without actually recording, as during a rehearsal. In this case, depress the *INPUT* selector to obtain source monitoring (not playback) when *not* in record mode.

Punch-in procedure "A"

1. Rewind to a point prior to where the punch-in will take place.
2. Release all RECORD MODE selector buttons so that both tracks are in safe mode; the LEDs above the meters should not be illuminated.
3. Depress the SYNC or REPRO buttons so playback will be heard from both tracks. The INPUT buttons may, of course, be depressed when necessary to monitor the record inputs but the sync button should be depressed during re-recording.
4. Simultaneously press the RECORD and PLAY buttons to initiate *playback*. The recorder is in record ready mode, and the LEDs above the VU meters whose tracks are selected by the RECORD MODE buttons will blink.
5. To commence the punch-in, press the RECORD MODE button(s) for the appropriate track(s); the LED above the active track VU meter(s) will stay on, and all other tracks' meter LEDs will turn off. The output signal(s) of the recording channel(s) automatically changes from tape out to source monitor.

6. To end the punch-in, either press STOP, or release the RECORD MODE button(s).

NOTE: A variation of this procedure allows the RECORD MODE selector(s) to be preset for recording on the desired channel(s). In that case, press PLAY to begin playback, then press PLAY and RECORD simultaneously to begin the punch-in.

7. For this procedure, the transport is put in the PLAY mode, and tape outputs, including the track(s) being recorded, can be monitored. The musicians then perform by listening to these signals through an externally mixed cue feed.
8. Punch-in can be cancelled by either depressing the STOP button or releasing the RECORD MODE button.

Punch-in procedure "B"

1. Rewind to a point prior to where the punch-in will take place.
2. Release all RECORD MODE selector buttons except for the track on which the punch-in is to be made; depress that RECORD MODE button. The LED above that track's VU meter should blink.
3. Depress all SYNC selector buttons.
4. Press the PLAY button to roll tape.
5. To commence the punch-in, step on the remote foot switch.
6. To end the punch-in, step on the foot switch a second time.

SECTION 5 EDITING

Once a tape has been recorded, it may be necessary to rearrange the order of some takes, splice two different reels of tape together, or, to add leader tape between takes on a given tape. All these operations are considered to be editing. To edit a tape, one should have the following materials available:

1. A splicing block. This is usually made of aluminum, with a groove to hold the tape, and one or more grooves cut across the length of the block to guide the cutter.
2. A sharp, non-magnetic single-edged razor blade. To be sure the blade has no residual magnetism, it can be demagnetized in much the same way that the head assembly is demagnetized (Section 7). Be sure to hold the blade securely, however, since a demagnetizer may pull strongly on the blade.

NOTE: *We do not recommend using scissors. Also, a magnetized razor blade will cause an audible "click" or "pop" at the point of the splice.*

3. A sharp white or yellow grease pencil to mark the intended splice point on the back of the tape.
4. A roll of 1/2" wide (1.3 cm) splicing tape. Splicing tape is specially manufactured for joining magnetic tape; it is thin, and has an adhesive that will adhere to the tape backing, yet not seep out of the splice under the typical pressures and temperatures encountered.

CAUTION: Never use conventional cellophane tape or packaging tapes for splicing. Some of the adhesive on such tapes may ultimately contaminate the recording tape, and may leave deposits on the tape heads and guides.

5. A supply of plastic or paper leader tape; plastic is stronger, but paper is easier to write upon with a pen or pencil, and is thus handy for making notes.

HIGH SPEED SEARCHING FOR AN EDIT POINT

If one is searching for the end of a take, or the beginning of another take, the search can be done in fast forward or rewind mode.

1. Turn down the monitor amplifier volume most of the way.
2. Press the A-2 REWIND or F. FWD button, and press the CUE lever toward the head assembly so that the tape lightly rests on the record/play head.
3. A high-pitched squeal will be heard during the program, with a moment of silence at the end of the program; at that point, hit the STOP button. Since the tape will probably overshoot the intended edit point, it may be necessary to use the opposite fast wind mode momentarily, then press STOP again.
4. For more precise location of the edit point, rewind slightly, then use PLAY to find the exact edit point and press STOP. (NOTE: Return the monitor volume to normal once fast-winding in cue mode has been completed).

SPILLING AN UNWANTED SEGMENT OF THE TAPE.

It may be desirable to "dump" a portion of the tape, such as a long pause or an unwanted segment of the program. First locate the beginning of the segment as indicated in the previous procedure.

1. Press down the head gate so it retracts and latches down. The edit point on the tape will be in contact with the record/play head (the head nearest to the takeup reel). Mark the back of the tape at the edit point with a grease pencil, then allow some slack and cut the tape.
2. Press the EDIT button to release the takeup reel tension (the reel brakes are still engaged).
3. To spill "unwanted" tape and find the next edit point, press the PLAY button. When the desired second edit point is heard, press STOP.
4. Splice the ends of tape from the two reels together, inserting a piece of leader tape between takes if desired.
5. Disengage the EDIT button and resume normal operation by taking up any slack so the tension arm sensors are actuated.

SECTION 6 CREATIVE USE OF THE PITCH CONTROL

The PITCH control can be used during recording or playback. Normally, these operations should be done with PITCH centered for two reasons, (a) tapes are made at calibrated speeds, and (b) the record/play equalization and the Dolby circuitry are properly aligned only at the normal running speed. There are instances when different speeds are useful.

RETIMING

If a recording has been made, say for a 60-second advertisement, and the overall program is a few seconds too short or too long, the PITCH control can be used during remixing to adjust the overall play time. The shift up or down in the frequency of the program should not be disturbing so long as a relatively small correction is used, say less than 5% (less than half the maximum speed deviation). A 5% speed change on a 60 second tape will add or subtract 3 seconds. In a longer program, say a 20 minute "side" for a record, a 5% change in length will amount to a full minute.

RETUNING

Suppose the initial track is recorded with the performer out-of-tune. During subsequent overdubs, it may be impractical or impossible to re-tune the instruments to match the de-tuned original track (it would be hard to retune a piano to match a trumpet whose slide was improperly placed). In this case, adjust the PITCH control up or down so that the playback pitch equals the pitch of the instrument which cannot be retuned. Then make the overdub at that speed. Subsequent overdubs and/or the mixdown can be done either at standard speed or the modified speed, as desired.

SPEEDING UP A PERFORMANCE WITHOUT CHANGING THE PITCH

When a performer wishes to play a complex passage at a tempo that would normally be difficult, if not beyond his ability, the PITCH control can be put to good use.

The technique is best used during an overdub, where at least one recorded track is available for a pitch (frequency) reference. When making the overdub, set the PITCH control so it slows down the tape (rotate CCW). The performer then plays in tempo with the slowed down tape. During this operation, be sure the instrument is tuned to the lower pitch heard in the monitors.

For playback, return the PITCH control to the normal setting (centered). The overdub will now be heard in-tune, at normal pitch, and at a faster tempo than it was actually performed.

SECTION 7 ROUTINE MAINTENANCE

Routine maintenance consists of cleaning the heads and other parts in the tape path, demagnetizing this area, and checking the electronic alignment (bias, level and equalization). Additional maintenance items that should be checked periodically include brake torque and pinch roller pressure.

CLEANING

Magnetic recording tape, no matter how good in quality, will always shed some of its oxide coating as it travels past the tape guides and head assembly. Whenever a small particle of oxide (or dust, dirt, hair, etc.) comes between the head and the tape, audible performance can be degraded, especially at high frequencies. Regular cleaning of the tape heads and guides will avoid such losses and restore full fidelity.

If the oxide should be scraped off a portion of the tape backing, there will be a momentary loss of sound (a drop out). Drop-outs are permanent flaws in the tape, and must be avoided. Clean guides and heads are less apt to scratch the tape. This is another reason for routine cleaning.

Standard tape head cleaning solvents are available from most Fostex dealers. An ideal solvent consists of 100% pure isopropyl alcohol. Rubbing alcohol *should not* be used; even though it is isopropyl, it usually contains water and oils which will leave an unwanted residue after cleaning.

CAUTION: Never use organic solvents such as methyl-ethyl ketone (MEK), lacquer thinner, acetone, etc. These can dissolve the materials that bind the heads together, and, if spilled, can mar or deform plastic parts.

Wipe the heads, tension arm rollers, tape guides, pinch roller, and capstan with a common cotton swab, moistened with the head cleaning fluid or alcohol. Allow the parts to air dry before threading a tape. (The process should be repeated until the swab no longer shows evidence of the reddish-brown oxide, and until the heads are shiny and clean.)

The exterior of the A-2 can be wiped with a cloth that is moistened with a weak detergent and water solution. Do not use solvents, oils, waxes or spray-on cleaners.

DEMAGNETIZATION

When a recording is made, the record/play head applies a powerful magnetic field to the tape. Iron oxide or similar magnetic particles in the recording tape store a portion of that magnetic field (this is the recording). It is a necessary law of physics that, as the recorded tape is subsequently played, some of the tape's magnetic field will be transferred to nearby metal parts. This residual magnetism is undesirable because it, in turn, can partially erase a tape. The purpose of demagnetization (degaussing) is to neutralize residual magnetism in the vicinity of the tape path.

Demagnetizing (also called degaussing) is accomplished by bringing a strong alternating magnetic field (created by a demagnetizer) near the head area, then withdrawing the field slowly. It is very important that this procedure be done carefully, and that no tapes be within 2 feet (0.6 meters) of the demagnetizer when it is operating. It is also important to turn off the A-2 during the time the demagnetizer is turned on.

CAUTION: Demagnetizers are not dangerous devices but if used improperly they can instantly erase a valuable tape, and can permanently magnetize metal parts—the opposite of the desired result. NEVER TURN ON OR EVEN PLUG IN A DEMAGNETIZER UNLESS IT IS AT LEAST 3 FEET (1 METER) AWAY FROM THE A-2. ALSO, NEVER TURN THE DEMAGNETIZER OFF UNTIL IT IS WITHDRAWN TO AN EQUAL DISTANCE OF AT LEAST 3 FEET. If the demagnetizer should be turned on or off nearby the A-2, it may impart a magnetic charge to the heads or tape guides which is too strong to be removed by the same demagnetizer.

There is no rule as to how often demagnetization must be done, but we recommend it be performed at least once for every 10 hours of A-2 record/play operation. We suggest observing the following procedure, step-by-step.

NOTE: Some demagnetizers do not have on/off switches, and must be plugged in and unplugged. This design may be safer because it avoids accidental switching when near the recorder. In these instructions, we assume that switchable demagnetizers are always turned on, and that power is controlled by plugging in or unplugging the unit from the AC mains.

1. Turn off the A-2, and the mixer and monitor amplifier. Remove any tapes to a distance of at least 6 feet (2 meters).
2. Before plugging in the demagnetizer, hold it at least 3 feet (1 meter) from the A-2. Then plug it in.
3. Gradually move the demagnetizer toward the recorder until the tip is about 1/8-inch (3 mm) from the heads.
4. Slowly pull the demagnetizer away from the heads to a distance of about 3 inches (75 mm), then back to within 1/8 inch of nearby metal parts (tape guides, capstan, etc.). Continue this process until the demagnetizer has been waved near all parts in the tape path, but DO NOT TOUCH ANY OF THE PARTS WITH THE DEMAGNETIZER PROBE.
5. Gradually withdraw the demagnetizer until it is at least 3 feet (1 meter) from the A-2. Then unplug the demagnetizer. This completes the demagnetization process.

CHECKING REPRODUCE ALIGNMENT

1. After cleaning and demagnetizing the transport, thread a reproduce alignment tape on the recorder.
Reproduce alignment tape (NAB):
Fostex P/N 82660050 (15 ips/38 cm/s)
Fostex P/N 82660070 (7-1/2 ips/19 cm/s)
or- °[MRL 21J105 (15 ips/38 cm/s)]
[MRL 21J104 (7-1/2 ips/19 cm/s)], Magnetic Reference Lab.
For wow/flutter measurement:
Fostex P/N 82660080 (15 ips/38 cm/s)
Fostex P/N 82660090 (7-1/2 ips/19 cm/s)
or- °[STL # 53-1 (15 ips/38 cm/s)]
[STL # 52-1 (7-1/2 ips/19 cm/s)], Standard Tape Lab.
2. Be sure all RECORD MODE selectors are released (safe mode), both REPRO buttons depressed, CAL/LINE OUT selector set to CAL and SPEED selector set to HIGH.

- Then, thread the 15 ips alignment tape on the recorder and play the tape.
- Both meters should indicate 0 VU levels during playback of the 1 KHz reference tone. If not, adjust the reproduce amplifier level for a 0 VU reading by the REP LEVEL pot (R205, 50K Ω , B). These pots are accessible by removing the bottom plate of the recorder.
 - Similarly, during playback of the 100 Hz and 10 KHz tones, both meters should indicate levels specified for the alignment tape. If not, adjust the playback equalization by the REP EQ HI pot (R204, 10K Ω , B). (Figure 7).
 - Set the INPUT/SYNC/REPRO selector to SYNC but all other controls as set in above Item 2, and play the alignment tape again.
 - As before, all meters should indicate 0 VU levels during playback of the 1 KHz reference tone. If not, adjust the reproduce amplifier level for a 0 VU, in the same way as for above REPRO mode checking and adjusting, by the SYNC LEVEL pot (R206, 20K Ω , B). Then, adjust the reproduce frequency response by the SYNC EQ HI pot (R203, 10K Ω , B).
 - Switch tape speed to LOW (7-1/2 ips), reproduce the 7-1/2 ips NAB alignment tape and check in same way as for high speed (15 ips).
If meter reading is off spec, set MONITOR selector to REPRO and adjust reproduce frequency response by the REP EQ LO pot (R202, 20K Ω , B).
Then, set the MONITOR selector to SYNC and adjust the reproduce frequency response again by the SYNC EQ LO pot (R201, 20K Ω , B).
 - Set the CAL/LINE OUT selector to LINE OUT and reproduce the 15 ips reproduce alignment tape.
Adjust the OUTPUT level control, on the amplifier trim panel, for a 0 VU reading on the meter.

NOTE 1: After adjusting the EQ pots, reproduce the reference level to check for a 0 VU reading, and if not, readjust the pots.

2: Whenever the HI EQ pots are adjusted, always check the LO speed frequency response and readjust if necessary.

CHECKING RECORD ALIGNMENT

- After performing the reproduce check, thread a blank recording tape on the transport (Ampex 357 or Scotch 227 is recommended) and set speed selector to HIGH (15 ips).
- Depress all RECORD MODE selectors (ready mode), and depress both INPUT buttons (INPUT mode).
- Apply a 1 KHz signal to the recorder inputs at nominal -10 dBV level. Both meters should indicate 0 VU. If not, adjust to 0 VU by the INPUT control knob on the trim panel. (see Figure 8.)
- Depress both REPRO buttons of the INPUT/SYNC/REPRO selectors, put transport in the record mode and adjust the REC LEVEL pot (R209, 2K Ω , B) for a 0 VU meter reading.

OVERALL FREQUENCY RESPONSE CHECK

- Taking channel L as an example, apply the input signal to INPUT L jack and connect an AC voltmeter to OUTPUT L. Then, put channel L in the record mode, and set the INPUT/SYNC/REPRO selector to REPRO.
Switch tape SPEED selector to HIGH, apply a -20 dBV (0.1V) signal of 40 Hz through 20 KHz to the INPUT jack, put transport in record mode, and check the overall frequency response.
It is in normal condition if, with reference to 400 Hz, the response is within ± 3 dB throughout the range of 40 Hz through 20 KHz.
If necessary, adjust the REC EQ HI pot (R211, 2K Ω , B).
Do the same on channel R.
- Switch tape SPEED to LOW, apply a -20 dBV (0.1V) signal of 40 Hz through 22 KHz to the INPUT jack, put transport in record mode, and check the overall frequency response.
It is in normal condition if, with reference to 400 Hz, the response is within ± 3 dB throughout the range of 40 Hz through 18 KHz.
If necessary, adjust the REC EQ LO pot (R210, 1K Ω , B).
Do the same on channel R.

BIAS LEVEL AND RECORD LEVEL ADJUSTMENTS

Switch tape SPEED to LOW and thread a blank tape on the transport.

Apply a 6.3 KHz signal of approximately -20 dBV (0.1V) to the INPUT jack and connect an AC voltmeter to the OUTPUT jack corresponding to the above INPUT jack.

Switch the INPUT/SYNC/REPRO selector to REPRO and depress the REC MODE button for the channel whose bias current is to be adjusted. Put transport in record mode, and after temporarily rotating the BIAS LEVEL pot (R208, 100 K Ω , B) fully CCW, slowly rotate it CW while watching the AC voltmeter. Fix the pot when the reading passes the peak and reaches 4 dB below peak level.

After completing bias level adjustments, check the overall frequency response for 15 ips and 7-1/2 ips speeds.

Figure 7. Reproduce alignment

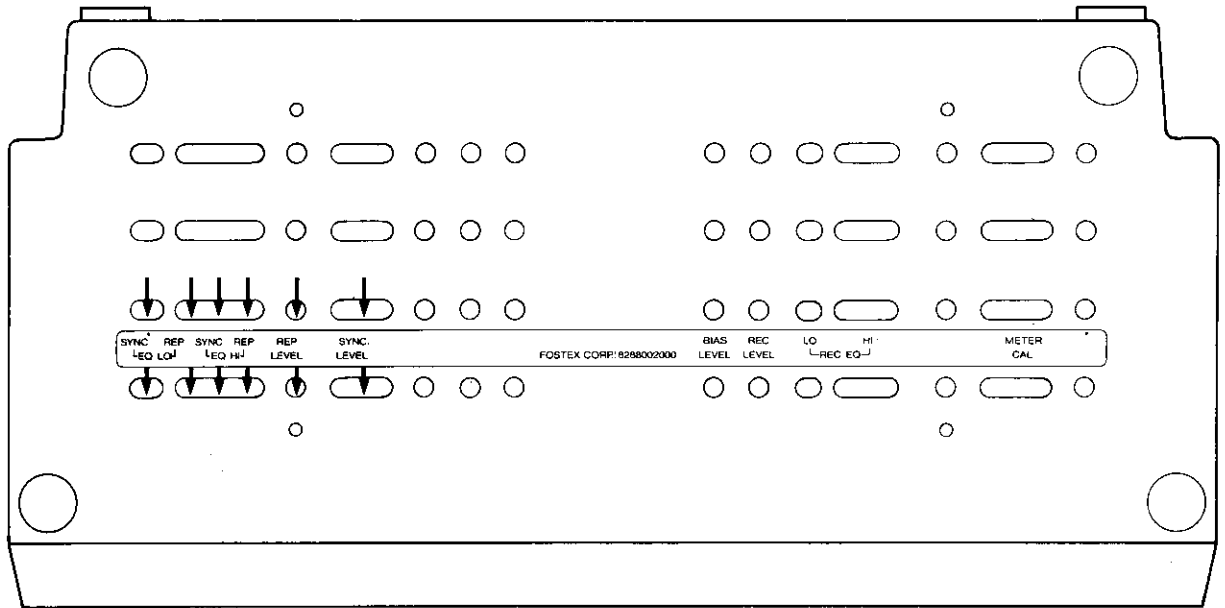
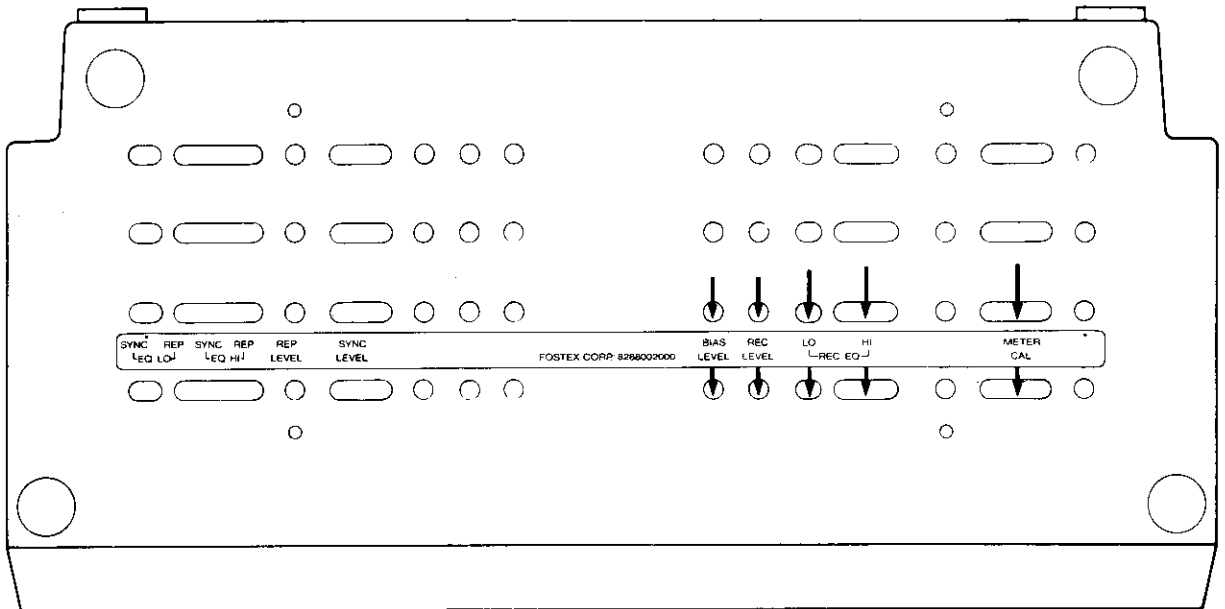

Figure 8. Record alignment



SPECIFICATIONS

TAPE	1/4 inch tape width, 1 mil base
FORMAT	2 track, 2 channel
HEADS	2 track record, 2 track reproduce, 2 track erase
REEL SIZE	7 inch
TAPE SPEED	15 and 7-1/2 ips (38 and 19 cm/s), $\pm 0.5\%$ $\pm 10\%$
PITCH CONTROL	
LINE INPUT	- 10 dBV (0.3 V) Impedance: 30 k Ω , unbalanced
LINE OUTPUT	- 10 dBV (0.3 V) Load impedance: 10 k Ω or higher, unbalanced
RECORD LEVEL CALIBRATION	0 VU referenced to 250 nWb/m of tape flux
EQUALIZATION	NAB (IEC available in Europe)
WOW & FLUTTER	$\pm 0.06\%$ peak (IEC/ANSI), wtd., at 15 ips $\pm 0.10\%$ peak (IEC/ANSI), wtd., at 7-1/2 ips
FAST WIND TIME	130 seconds typ. for 1800 ft. of tape
OVERALL FREQUENCY RESPONSE	40 Hz ~ 20 kHz, ± 3 dB, at 15 ips 40 Hz ~ 18 kHz, ± 3 dB, at 7-1/2 ips
SIGNAL-TO-NOISE RATIO (SYNC/REPRODUCE)	65 dB wtd., at 15 and 7-1/2 ips, referenced to 1 kHz, 3% THD level
THD	Less than 1% at 1 kHz, 0 VU
CROSSTALK (REPRODUCE)	50 dB (at 1 kHz)
ERASURE POWER REQUIREMENTS	Better than 70 dB at 1 kHz 120 V, AC, 60 Hz, 35 W
DIMENSIONS	13-1/2" (H) x 14" (W) x 6-3/4" (D) 340 mm (H) x 360 mm (W) x 170 mm (D)
WEIGHT	29 lbs (13 Kg)

Optional Accessories

8030 Remote Control
8050 Punch-In/Out Footswitch
9050 Flight Case
9007 7" Metal Reel
9901-1 Rack Mount Adaptor
9901-2 Filler Panel

SAFETY INSTRUCTIONS

WARNING

“READ BEFORE OPERATING”

1. Read Instructions—All the safety and operating instructions should be read before the appliance is operated.
2. Retain Instructions—The safety and operating instructions should be retained for future reference.
3. Heed Warnings—All warnings on the appliance and in the operating instructions should be adhered to.
4. Follow Instructions—All operating and use instructions should be followed.
5. Water and Moisture—The appliance should not be used near water—for example, near a bathtub, washbowl, kitchen sink, laundry tub, in a wet basement, or near a swimming pool, etc.
6. Ventilation—The appliance should be situated so that its location or position does not interfere with its proper ventilation. For example, the appliance should not be situated on a bed, sofa, rug, or similar surface that may block the ventilation openings; or, placed in a built-in installation, such as a bookcase or cabinet that may impede the flow of air through the ventilation openings.
7. Heat—The appliance should be situated away from heat sources such as radiators, heat registers, stoves, or other appliances (including amplifiers) that produce heat.
8. Power Sources—The appliance should be connected to a power supply only of the type described in the operating instructions or as marked on the appliance.
9. Power-Cord Protection—Power-supply cords should be routed so that they are not likely to be walked on or pinched by items placed upon or against them, paying particular attention to cords at plugs, convenience receptacles, and the point where they exit from the appliance.
10. Cleaning—The appliance should be cleaned only as recommended by the manufacturer.
11. Nonuse Periods—The power cord of the appliance should be unplugged from the outlet when left unused for a long period of time.
12. Object and Liquid Entry—Care should be taken so that objects do not fall and liquids are not spilled into the enclosure through openings.
13. Damage Requiring Service—The appliance should be serviced by qualified service personnel when:
 - A. The power-supply cord or the plug has been damaged; or
 - B. Objects have fallen, or liquid has been spilled into the appliance; or
 - C. The appliance has been exposed to rain; or
 - D. The appliance does not appear to operate normally or exhibits a marked change in performance; or
 - E. The appliance has been dropped, or the enclosure damaged.
14. Servicing—The user should not attempt to service the appliance beyond that described in the operating instructions. All other servicing should be referred to qualified service personnel.

Fostex

FOSTEX CORPORATION 512, MIYAZAWACHO, AKISHIMA, TOKYO, JAPAN

FOSTEX CORPORATION OF AMERICA 15431 BLACKBURN AVE., NORWALK, CA 90650, U.S.A.

© PRINTED IN JAPAN JAN. 1982 8288008000