

# AR501 MIC PREAMPLIFIER

## Owner's Manual

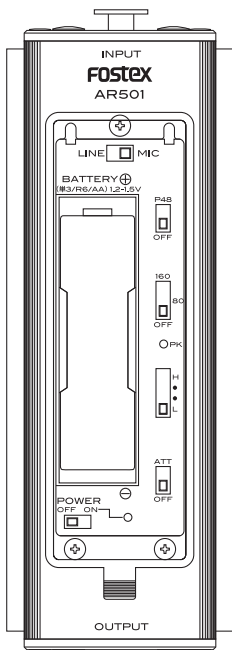

## Table of contents

1. Names and functions . . . . .	3
2. Input and Output . . . . .	6
3. Switches and LED's inside Battery Cover . .	9
4. Power supply . . . . .	15
5. Chassis . . . . .	17
6. Accessories . . . . .	19
7. Typical connections . . . . .	21
8. Input and Output specifications . . . . .	22
9. Performances . . . . .	24
10. Dimensions and weight . . . . .	25
11. Block Diagram . . . . .	27

# 1. Names and functions

## < Input Panel >

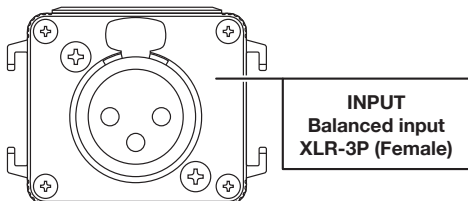

## < Output Panel >

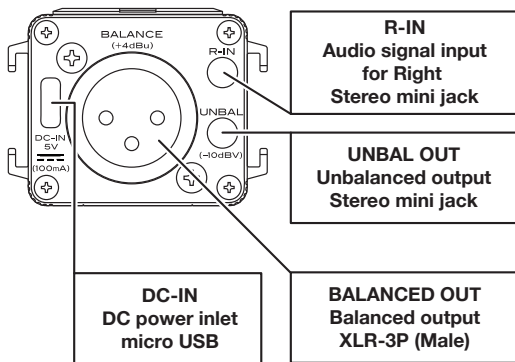

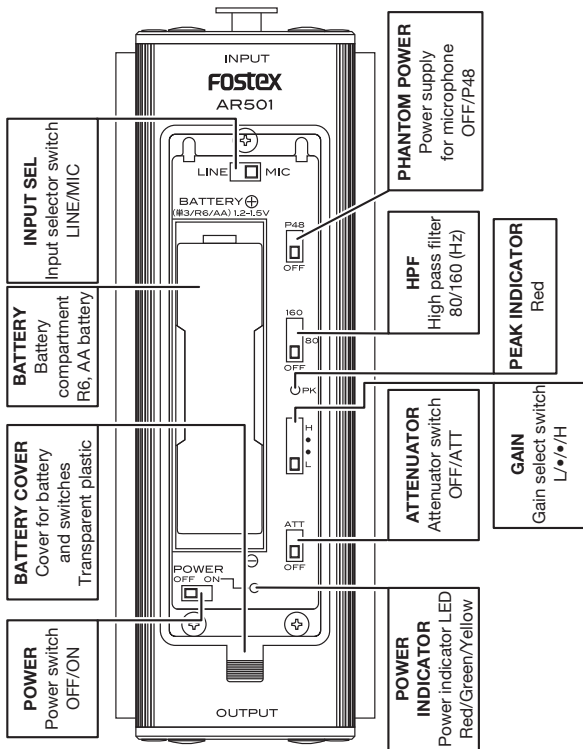

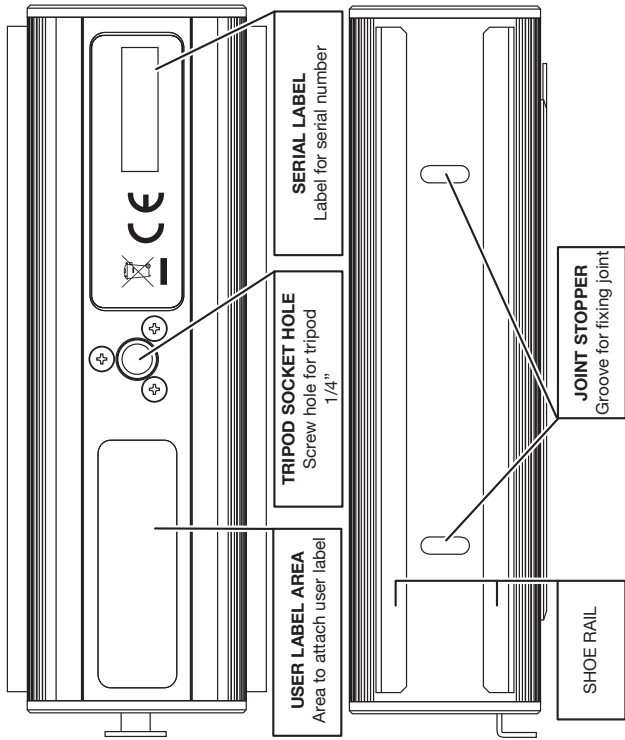

## 2. Input and Output

< Input >

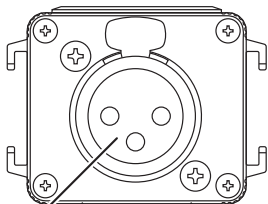

### INPUT Connector

Connect here the output from microphone or line level equipment.  
Use INPUT SEL switch according to the type of device connected.  
(Refer to 3. Switches and LED' s inside Battery Cover.)

[Connector]: XLR (Female) / Pin: 3 pins (Pin No.2 as HOT)

[Input impedance]

LINE: 10k $\Omega$  or higher

MIC: 2k $\Omega$  or higher

[Input level]

INPUT SEL	Nominal	Max
MIC	-60/-45/-30/-20 dBu	-40/-25/-10/0 dBu
LINE	+4dBu	+24dBu

## < Output >

### **BALANCED OUT Connector**

Output the line level audio signal in balanced configuration.

[Connector]: XLR (Male) / Pins: 3 pins / No.2 as HOT

[Nominal output level]: +4dBu

[Max. output level]: +24dBu

[Applicable load impedance]: 10k $\Omega$  or more

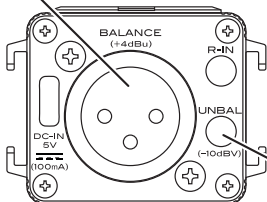

### **UNBALANCED OUT Connector**

Output the audio signal in unbalanced configuration. (The same signal will appear on both L and R channels.)

You can reduce the output level by using ATT switch.

((Refer to 3. Switches and LED' s inside Battery Cover)).

[Connector]: Stereo mini jack /  $\phi$ 3.5 mm

[Nominal output level]: -10dBV

[Max. output level]: +10dBV

ATT	Nominal	MAX
OFF	-10dBV	+10dBV
ON	-50dBV	-30dBV

< Misc. >

**R-IN connector**

Connecting a line level audio signal here will result an output via UNBALANCED OUT connector Right channel.

It is useful when connecting another AR501 to perform in stereo.

[Connector]: Stereo mini jack /  $\varnothing 3.5\text{mm}$

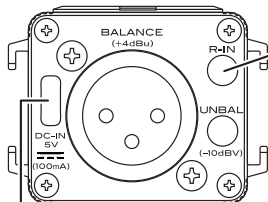

**DC-IN connector**

Use to connect an external power source.

Recommended DC voltage is 5V.

An ordinary mobile battery pack can be used.

[Connector]: micro USB

[Input voltage]:  $5\text{V}\pm 3\%$

[Current consumption]: 100mA peak.

Note: When incoming voltage goes below the above spec. or if it cuts out, AR501 will automatically switch the power source to internal battery.



### 3. Switches and LED's inside Battery Cover

#### INPUT SEL Switch

Use INPUT SEL switch according to the type of equipment connected.

<b>MIC</b>	For dynamic or condenser type microphone
<b>LINE</b>	For line level equipment such as an audio mixer.

\* When choosing LINE, no signal becomes available on BALANCED OUT connector.

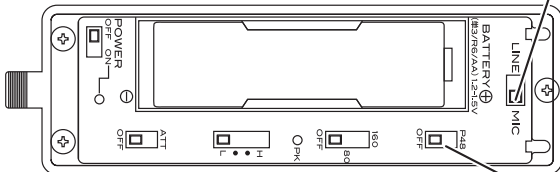

#### PHANTOM POWER Switch

Power supply for condenser microphone

<b>OFF</b>	No voltage supplied.
<b>P48</b>	48V voltage is supplied to INPUT connector. 24V will be supplied at power saving mode.

### HPF (High Pass Filter) Switch

Used to reduce low frequency noise such as wind blow on the microphone or hum noise generated by AC power facility.

<b>80</b>	Reducing the frequency range of 80Hz and below.
<b>160</b>	Reducing the frequency range of 160Hz and below.

\* Attenuation: -6dB/oct.

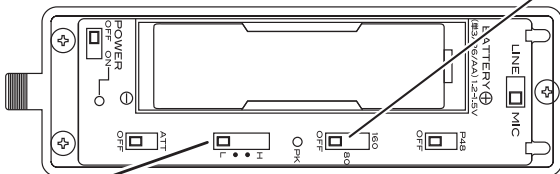

### GAIN Switch and PEAK Indicator

Used to adjust the microphone amp gain according to the microphone sensitivity. Set the GAIN switch appropriately referring to the PK (PEAK indicator) LED and the input level of equipment connected to OUTPUT.

	MIC Sensitivity (dBu)	GAIN (dB)
<b>H</b>	-60	+64
<b>.</b>	-45	+49
<b>.</b>	-30	+34
<b>LINE</b>	-20	+24

\* When the GAIN is adjusted properly according to the chart above, the nominal level will appear via OUTPUT connector.

**POWER Switch**  
Main power switch  
of AR501

**Battery Compartment**  
Insert a piece of AA battery.  
Type of battery: Ni-MH (Nickel  
Metal Hydride), Alkaline

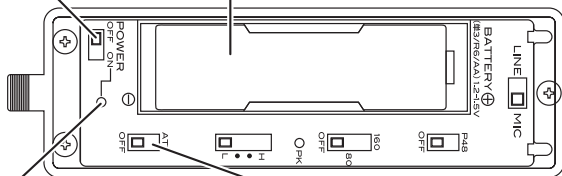

**POWER INDICATOR**  
Power indicator LED.  
(For detail, refer to next page.)

**OUTPUT ATT Switch**







Used to attenuate the signal level at UNBALANCED OUT.  
Set to ON when connecting to low input equipment such as  
mic in of DSLR camera.

<b>OFF</b>	No attenuation (nominal output level: -10dBV)
<b>ON</b>	Attenuation applied (nominal output level: -50dBV)

### < POWER Indicator >

Lit when power turns ON. LED condition differs depending on the function mode.

[Internal battery]: Right after powering on

Lighting pattern	
<b>Normal mode / Preparing to setting up</b>	
 (1 sec.) x 3 times	 Green Flashing green twice rapidly for 3 sec. period
<b>Power saving mode / Preparing to setting up</b>	
 (1 sec.) x 3 times	 Green Flashing green once slowly for 3 sec. period
<b>Setup completed</b>	
	 Red Flashing red 3 times rapidly

If you operate the PHANTOM POWER switch from OFF to ON to OFF during the setting up period, AR501 will enter Power saving mode.











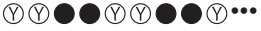

It will reduce the internal circuitry working voltage and cut down the power consumption by approx. 40%. (The supply voltage at P48 is going to be 24V during the power saving mode.)

The power saving mode will be memorized internally.

In order to cancel the mode, turn the power OFF once, then repeat the same MIC POWER switch operation again.

During operation, the indicator will perform as following.

[Internal battery]: During normal mode operation

Lighting pattern		P48	BATT. amount
	Flashing: Green 2 times 	OFF	High
	Flashing: Yellow 2 times 	ON	High
	Flashing: Green 2 times Red 1 time  	OFF	Low
	Flashing: Yellow 2 times Red 1 time  	ON	Low
	Lit solid Red 	Forced to OFF	Run out

\* Replace the battery when Red LED becomes flashing.

\* Replace the battery immediately when Red LED is lit solid as the power is forced to OFF on both internal circuitry as well as P48.

[Internal battery]: During power saving mode operation

Lighting pattern		P48	BATT. amount
ⓐ ●●● ⓐ ●●● ⓐ ●●●	Flashing: ⓐ Green	OFF	High
Ⓨ ●●● Ⓨ ●●● Ⓨ ●●●	Flashing: Ⓨ Yellow	ON	High
ⓐ Ⓡ ●● ⓐ Ⓡ ●● ⓐ ●●	Flashing: ⓐ Green 1 time Ⓡ Red 1 time	OFF	Low
Ⓨ Ⓡ ●● Ⓨ Ⓡ ●● Ⓨ ●●	Flashing: Ⓨ Yellow 1 time Ⓡ Red 1 time	ON	Low
Ⓡ ●●●	Lit solid Ⓡ Red	Forced to OFF	Run out

\* The supply voltage at P48 is 24V during the power saving mode.

\* Replace the battery when Red LED becomes flashing.

\* Replace the battery immediately when Red LED is lit solid as the power is forced to OFF on both internal circuitry as well as P48.

[DC IN]: During operation

Lighting pattern		P48
ⓐ ●●●	Lit solid: ⓐ Green	OFF
Ⓨ ●●●	Lit solid: Ⓨ Yellow	ON

\* During DC-IN operation, no preparation to the setting up will not be executed.

\* During DC-IN operation, the battery amount is not detected.

## 4. Power

< Internal Battery >

AR501 uses a piece of AA battery.

The suited type of battery is N-MH rechargeable battery or Alkaline battery.

\* AR501 does not have battery charging function.

Operating time reference value.

Battery Type	Normal Mode		Power saving mode	
	P48 (Power to mic)		P48 (Power to mic)	
	OFF	ON	OFF	ON
Alkaline Batt. (LR6)	Approx. 9 hours	Approx. 3 hours	Approx. 15 hours	Approx. 8 hours
Ni-MH (eneloop)	Approx. 10 hours	Approx. 4 hours	Approx. 16 hours	Approx. 9 hours
Ni-MH (eneloop pro)	Approx. 12 hours	Approx. 5 hours	Approx. 18 hours	Approx. 11 hours

### Caution

\* The above chart is only a reference. It does not guarantee the actual operating time. The operating time differs depending on the using condition and environmental variations.

\* Ni-MH battery gradually reduce its max. capacity by repeating the cycle of discharge.

\* For the measurement of the above chart, we have used brand new Ni-MH battery once discharged and then fully charged.

## Memo

\* As spontaneous self-discharge occurs on Ni-MH battery, we recommend using it immediately after charging or charge it right before using. Alternatively, we recommend the next generation rechargeable battery that has improved self-discharge characteristic such as "enloop".

\* As Alkaline battery drastically reduces its discharge characteristic under low temperature, we recommend Ni-MH battery under such circumstances.

\* enloop is a registered trade name.

## < External Power >

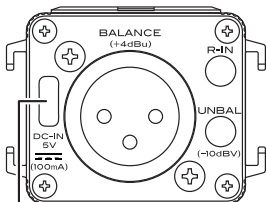

### **DC-IN Connector**

AR501 can be powered by connecting an external power source to DC-IN such as mobile battery pack.

## Memo

\* When powered by an external power source, AR501 does not consume the power from internal battery.

\* The power indicator becomes lit (use of internal battery makes the indicator flashing.).

\* If the external power cuts out with some reason, it will automatically switch the power source to the internal battery. It is possible to use the external power as main source and internal battery as backup source.



## 5. Chassis

< Screw hole for tripod >

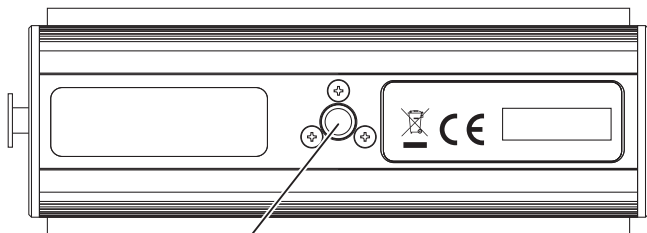

AR501 provides 1/4" thread on the bottom chassis so that you can attach it to a standard tripod and camera gear.

< Shoe rail >

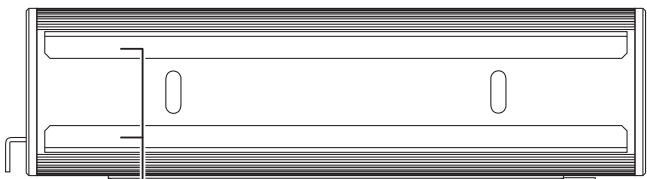

By inserting the joint plate comes in the package here, multiple number of AR501 can be jointed. Please refer to < Joint > on the section 6. Accessories for more details.

< Attaching user label >

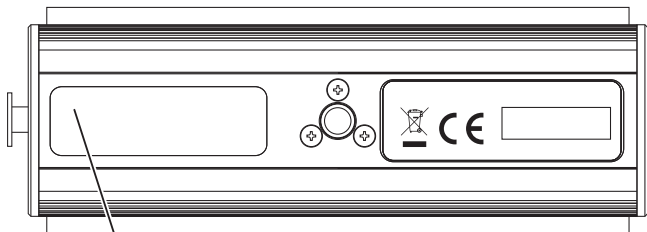

AR501 has a pit on the bottom chassis to stick a user label for the users' convenience. Use it for attaching a label in the way you like such as company ID and administrative control number plate. Since the pit is retracted, it avoids the label getting damaged when attaching a tripod.  
Recommended label dimensions: 41 x 13 mm, Corner R 2.5 mm

## 6. Accessories

< Joint (coupling plate) >

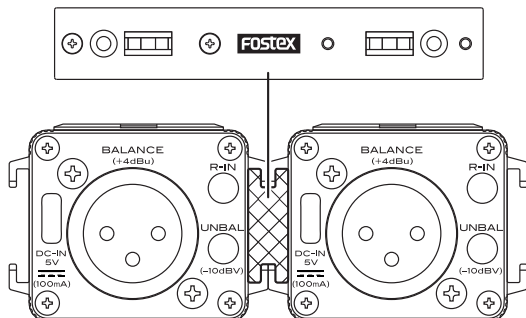

Used to joint multiple numbers of AR501.

Make the shoe rail of every unit facing each other and insert the joint in between.

Fit the joint to one unit first and then attach the other later.

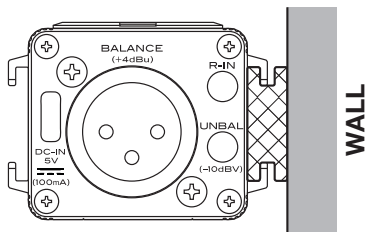

Other purpose of joint is; fixing the joint to somewhere like a wall using 3 mm in diameter screw holes, then attach the AR501 to the joint. Recommended screw: 3 mm in diameter, more than 10 mm in length, counter-sunk type screw (other type cannot be used).

**\* Before fixing the joint, ensure the fixing area has enough strength to hold the AR501.**

< Reference dimensions >

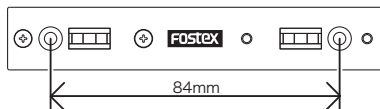

< Cable >

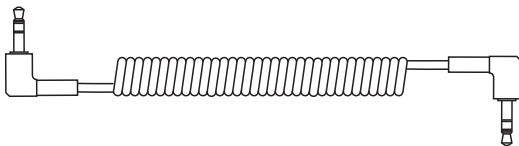

Used to connect AR501 unbalanced output to other equipment such as a DSLR camera and audio recorder and also to connect 2 x AR501's in cascade.

For the convenience of handling, a curl cord is used.

[Connectors]: stereo min plug  $\varnothing$  3.5 mm.

[Length]: 20 cm when shrunk, 40 cm when fully expanded.

## 7. Typical Connection

< For movie recording using a digital camera (DSLR) with audio input >

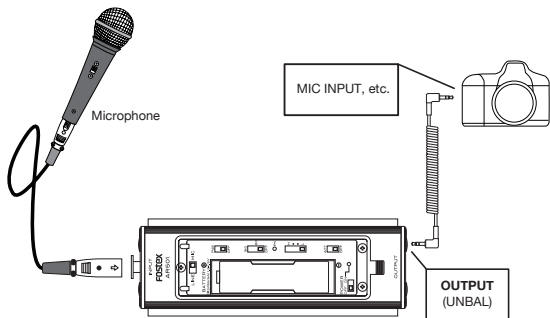

\* If the audio input level of DSLR is fixed to MIC level, set the AR501 ATT switch to ATT position. Refer to the DSLR owner's manual for the details.

\* When using a line level source such as an audio mixer and wishing to convert the output from BALANCED to UNBALANCED by AR501, set the INPUT SEL switch to LINE.

< Connection with an audio mixer >

To be used as a microphone amplifier and to avoid external noise when the microphone and audio mixer are located apart.

### Usage example

\* To connect the microphone located on the stage or ceiling of hall to the mixer.

\* For relay broadcasting at a sport event.

(A waterproof countermeasure needs to be taken on AR501 when using at outdoor.)

\* In the electrically noisy environment such as with large lighting facility.

## 8. Input and Output Specifications

< Analog Input >

- Balanced

XLR-3-31 type (Electrically balanced)

1: GND, 2: HOT, 3: COLD

LINE

Input impedance: 10 k $\Omega$  or more

Nominal input level: +4 dBu

Max. input level: +24 dBu

MIC

Input impedance: 2 k $\Omega$  or more

Nominal input level: -60 ~ -20 dBu

Max. input level: 0 dBu

Unbalanced

IR-IN:  $\phi$ 3.5 mm stereo mini jack

\* Incoming signal goes through unbalanced output.

< Analog Output >

- Balanced

XLR-3-32 type (Electrically balanced)

1: GND, 2: HOT, 3: COLD

Applicable load impedance: 10 k $\Omega$  or more

Nominal output level: +4 dBu

Max. output level: +24 dBu (+20 dBu at power saving mode)

- Unbalanced

ø3.5 mm stereo mini jack

Applicable load impedance: 10 k $\Omega$  or more

Nominal output level: -10 dBV (-50 dBV at ATT ON)

Max. output level: +10 dBV (-30 dBV at ATT ON)

< Power supply for microphone >

48  $\pm$  4 V

24  $\pm$  2 V at power saving mode

## 9. Performance

< Frequency Response >

- LINE IN - OUPUT (Unbalanced)  
20 ~ 20,000 Hz  $\pm$  1 dB (reference level)
- MIC IN - OUTPUT (Balanced)  
GAIN: Low (-20 dB)  
20 ~ 20,000 Hz  $\pm$  1 dB (reference level)  
GAIN: Hi (-60 dB)  
20 ~ 20,000 Hz  $\pm$  3 dB (reference level)

< Signal-to-Noise Ratio (A-WEIGHT) >

- LINE IN - OUPUT (Unbalanced)  
90 dB or more
- MIC IN - OUTPUT (Balanced)  
60 dB or more (equivalent input noise: -125 dBu)  
GAIN: Hi (gain: +64 dB), Input: 150  $\Omega$  terminated.

< Total Harmonic Distortion (THD + N, LPF: 20 kHz) >

- LINE IN - OUTPUT (Unbalanced)  
0.005 % or less at 1 kHz / +4 dBu
- MIC IN - OUTPUT (Balanced)  
0.01 % or less at 1 kHz / -20 dBu (GAIN: Low)  
0.1 % or less at 1 kHz / -60 dBu (GAIN: Hi)

< HPF >

- HPF 80 Hz:  $-3 \pm 1$  dB
- HPF 160 Hz:  $-3 \pm 1$  dB

< Peak LED Lighting Level >

- Clipping level: - 1dB



## **10. Dimensions and Weight**

< Dimensions >

W 42.8 mm x H 31.6 mm x D 116 mm

< Weight >

Approx. 110 g (without battery)

Approx. 150 g (with eneloop AA battery x 1)

< External View >

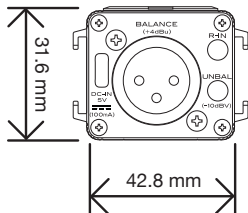
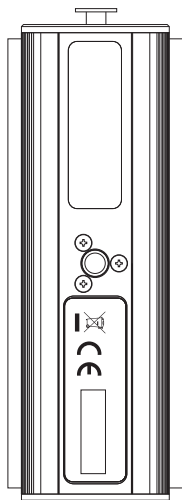
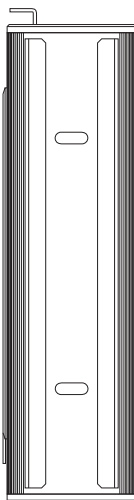
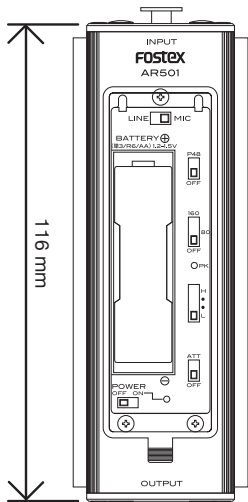
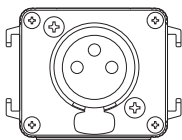

## 11. Block Diagram

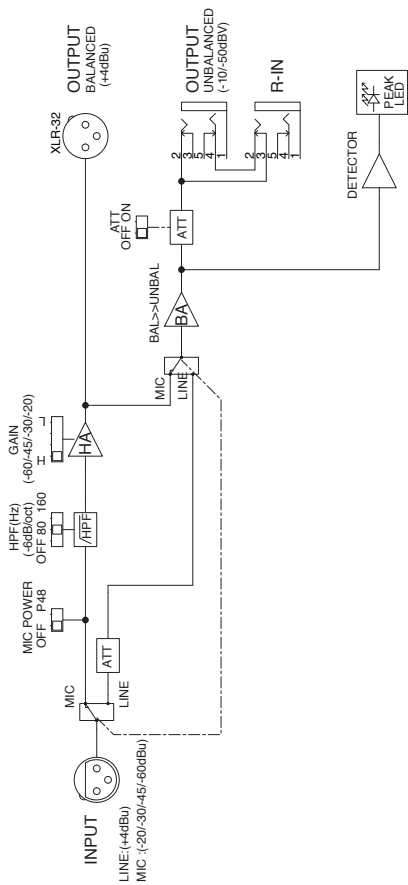

**Fostex**<sup>®</sup>

FOSTEX COMPANY

1-1-109, Tsutsujigaoka, Akishima City, Tokyo, 196-8550, Japan

PRINTED IN JAPAN AUGUST 2013 578831 (8588125000)